

1. Electricity

Very Short Answer Type Questions-Pg-5

1. Question

By what other name is the unit Joule/Coulomb called?

Answer

Potential Difference is said to be **1 Volt** between two points if 1 Joule of work is done in moving 1 coulomb of electric charge from one point to another.

$$1 \text{ Volt} = \frac{1 \text{ Joule}}{1 \text{ Coulomb}}$$

2. Question

Which of the following statements correctly defines a volt?

- (a) A volt is a joule per ampere.
- (b) A volt is a joule per coulomb.

Answer

The second statement defines "volt" correctly.

Explanation: One Volt is the electric potential energy per unit charge, and is measured in joules per coulomb.

3 A. Question

What do the letters p.d. stand for?

Answer

p.d. stands for potential difference. Potential difference between two points in a circuit is the work done in moving unit charge (i.e. one coulomb) from one point to the other.

3 B. Question

Which device is used to measure p.d.?

Answer

Voltmeter is a device which is used to measure potential difference between two point in an electric circuit.

4. Question

What is meant by saying that the electric potential at a point is 1 volt?

Answer

Electric Potential at a point being 1 volt means that 1 joule of work is done in moving 1 unit positive charge from infinity to that point

5. Question

How much work is done when one coulomb charge moves against a potential difference of 1 volt?

Answer

1 Joule of work is done when 1 coulomb of charge moves against a potential difference of 1 volt.

As potential difference = $\frac{\text{Work done}}{\text{Charge moved}}$

6. Question

What is the SI unit of potential difference?

Answer

The SI unit of potential difference is volt, which is also known as Joule/Coulomb

7. Question

How much work is done in moving a charge of 2 C across two points having a potential difference of 12 V?

Answer

Given, charge = 2 C

Potential difference between two points = 12V

Work done (W) =?

We know that;

$$V = W/Q$$

$$\text{Or, } W = V \times Q$$

$$\text{Or, } W = 12 \text{ V} \times 2 \text{ C} = 24 \text{ J}$$

8. Question

What is the unit of electric charge?

Answer

The SI unit of electric charge is coulomb (C).

9. Question

Define one coulomb charge.

Answer

One coulomb is that amount of electric charge that repels an equal and similar charge with a force of 9×10^9 N when placed in vacuum at a distance of one metre from it.

10. Question

Fill in the following blanks with suitable words :

(a) Potential difference is measured in by using a placed in across a component.

(b) Copper is a good plastic is an

Answer

(a) Potential difference is measured in **volts** by using a **voltmeter** placed in **parallel** across a component.

(b) Copper is a good **conductor** plastic is an **insulator**

Short Answer Type Questions-Pg-5

11. Question

What is meant by conductors and insulators? Give two examples of conductors and two of insulators.

Answer

Those substance which allow electric current to pass through them easily is called conductors. Examples. Iron, copper, zinc e.t.c

Those substance which do not allow electric current to pass through them is called Insulators. Examples. Mica, Air, Paper, e.t.c

12. Question

Which of the following are conductors and which are insulators?

Sulphur, Silver, Copper, Cotton, Aluminium, Air, Nichrome, Graphite, Paper, Porcelain, Mercury, Mica, Bakelite, Polythene, Manganin.

Answer

Conductor allow electric current to pass through them, so here conductors are Silver, Copper, Aluminum, Nichrome, Graphite, Mercury, Manganin and insulator do not allow current to pass through them, so here insulators are Sulphur, Cotton, Air, Paper, Porcelain, Mica, Bakelite, Polythene

13. Question

What do you understand by the term "electric potential"? (or potential) at a point? What is the unit of electric potential?

Answer

Electronic Potential or Potential is defined as the work done in moving a unit positive charge from infinity to a particular point. It is denoted by **V** and its unit is "**Volt**".

14 A. Question

State the relation between potential difference, work done and charge moved.

Answer

Electric potential difference is known as voltage, which is equal to the work done per unit charge to move the charge between two points against static electric field.

$$\text{Voltage} = \frac{\text{Work done}}{\text{Charge}}$$

14 B. Question

Calculate the work done in moving a charge of 4 coulombs from a point at 220 volts to another point at 230 volts.

Answer

Here charged moved = 4 C

Potential difference = $V_2 - V_1 = 230V - 220V = 10 V$

So as we know that

Work done = Potential difference \times Charge moved

= $10 \times 4 = 40$ joule

So, the work done in moving a charge of 4 coulombs from a point at 220 volts to another point at 230 volts is 40 Joule.

15 A. Question

Name a device that helps to measure that potential difference across a conductor.

Answer

Voltmeter is an apparatus used to measure the potential difference or electric potential difference between two points in an electric circuit.

15 B. Question

How much energy is transferred by a 12 V power supply to each coulomb of charge which it moves around a circuit?

Answer

Here potential difference = 12 V

Charge moved = 1 C

Work done = Potential difference \times Charge moved

= $12 \times 1 = 12$ joule

So 12 J energy is transferred by a 12 V power supply to each coulomb of charge which it move around a circuit.

Long Answer Type Questions-Pg-6

16 A. Question

What do you understand by the term "potential difference"?

Answer

The difference in electric potential between two points is known as potential difference. The potential difference between two points in an electric circuit is defined as the amount of work done in moving a unit charge from one point to the other point.

16 B. Question

What is meant by saying that the potential difference between two points is 1 volt?

Answer

One volt is defined as the work done by one joule to move a charge of one coulomb from one place to another.

$$1 \text{ Volt} = \frac{1 \text{ joule}}{1 \text{ coulomb}}$$

16 C. Question

What is the potential difference between the terminals of a battery if 250 joules of work is required to transfer 20 coulombs of charge from one terminal of battery to the other?

Answer

As we know that

$$\text{Potential difference} = \frac{\text{Work done}}{\text{Charge move}}$$

Here, work done = 250 Joule

Charge move = 20 C

So,

$$\begin{aligned} \text{Potential Difference} &= \frac{250J}{20C} \\ &= 12.5JC^{-1} \\ &= 12.5 \text{ Volt} \end{aligned}$$

16 D. Question

What is the voltmeter? How is a voltmeter connected in the circuit to measure the potential difference between two points? Explain with the help of a diagram.

Answer

Voltmeter is an apparatus used to measure the potential difference or electric potential difference between two points in an electric circuit.

The voltmeter is always connected in parallel across the two points where the potential difference is to be measured.

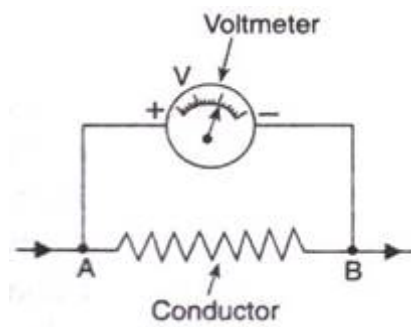

16 E. Question

State whether a voltmeter has a high resistance or a low resistance. Give reason for your answer.

Answer

A voltmeter has a high resistance so that it takes a negligible current from the circuit. The term volt gives rise to the word voltage. Voltage is the other name for potential difference

Multiple Choice Questions (MCQs)-Pg-6

17. Question

The work done in moving a unit charge across two points in an electric circuit is a measure of:

- A. Current
- B. potential difference
- C. resistance
- D. power

Answer

Potential difference between two points in a circuit is the work done in moving unit charge (i.e. one coulomb) from one point to the other.

18. Question

The device used for measuring potential differences is known as:

- A. potentiometer
- B. ammeter
- C. galvanometer
- D. voltmeter

Answer

The device used to measure the potential difference between two points in volts is known as voltmeter.

19. Question

Which of the following units could be used to measure electric charge?

- A. ampere
- B. joule
- C. volt
- D. coulomb

Answer

Coulomb is the SI unit of electric charge which is equal to the amount of charge transported by a current of one ampere in one second.

20. Question

The unit for measuring potential difference is:

- A. watt
- B. ohm
- C. volt
- D. kWh

Answer

Volt is the electrical unit of voltage or potential difference. One Volt is defined as energy consumption of one joule per electric charge of one coulomb.

21. Question

One coulomb charge is equivalent to the charge contained in:

- A. 2.6×10^{19} electrons
- B. 6.2×10^{19} electrons
- C. 2.65×10^{18} electrons
- D. 6.25×10^{18} electrons

Answer

One coulomb is the amount of charge that passes a point each second when the current is one amp. One coulomb is also equal to the charge contained in 6.24×10^{18} electrons.

Very Short Answer Type Questions-Pg-11

1. Question

By what name is the physical quantity coulomb /second called?

Answer

SI unit of electric current is ampere (A). Ampere is the flow of electric charges through a surface at the rate of one coulomb per second.

2. Question

What is the flow of charge called?

Answer

The flow of electric charge is known as electric current. Electric current is carried by moving electrons through a conductor.

3. Question

What actually travels through the wires when you switch on a light?

Answer

When we switch on a light electrons or charge are travelled through the wire.

4. Question

Which particles constitute the electric current in a metallic conductor?

Answer

The electric current is constituted by electron in a metallic conductor.

5 A. Question

In which direction does conventional current flow around a circuit?

Answer

The direction of an electric current is by convention the direction in which a positive charge would move. Thus, the current in the external circuit is directed away from the positive terminal and toward the negative terminal of the battery.

5 B. Question

In which direction do electrons flow?

Answer

Electrons would actually move through the wires in the opposite direction i.e. from negative terminal to positive terminal.

6. Question

Which of the following equation shows the correct relationship between electrical units?

$$1 \text{ A} = 1 \text{ C/s or } 1 \text{ C} = 1 \text{ A/s}$$

Answer

If 1 coulomb of electric charge flows through a cross section for 1 second, it would be equal to 1 ampere.

Therefore; $1 \text{ A} = 1 \text{ C/1 s}$

7. Question

What is the unit of electric current?

Answer

SI unit of electric current is ampere (A).

8 A. Question

How many milli-amperes are there in 1 ampere?

Answer

Small quantity of electric current is expressed in milliampere and microampere. Milliampere is written as mA and microampere as μA

$$1\text{mA (milliampere)} = 10^{-3} \text{ A}$$

8 B. Question

How many micro-amperes are there in 1 ampere?

Answer

$$1\mu\text{A (microampere)} = 10^{-6} \text{ A}$$

9. Question

Which of the two is connected in series: ammeter or voltmeter?

Answer

If the voltmeter is connected in series then the potential diff between two consecutive points will be zero. Thus voltmeter is useless. Ammeter is used to measure the current flowing in a branch.

10. Question

Compare how an ammeter and a voltmeter are connected in a circuit.

Answer

If the voltmeter is connected in series then the potential diff between two consecutive points will be zero. Thus voltmeter is useless. Ammeter is used to measure the current flowing in a branch. If it is connected in parallel, then the current will be divided between different branches. So voltmeter is connected in parallel and ammeter is connected in series.

11. Question

What do the following symbols mean in circuit diagrams?

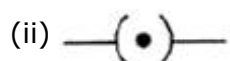

Answer

- (i) This symbol represents variable resistance or rheostat
(ii) This symbol represents a closed switch or a closed plug key.

12. Question

If 20 C of charge pass a point in a circuit in 1 s, what current is flowing?

Answer

The flow of electric charge is known as electric current. Here 20 C charge pass in a circuit in one second.

$$I = \frac{q}{t} = \frac{20}{1} = 20 \text{ A}$$

13. Question

A current of 4 A flows around a circuit for 10 s. How much charge flows past a point in the circuit in this time?

Answer

Here current $I = 4 \text{ A}$ and Time = 10 sec

So charge = Current \times time

$$= 4 \times 10 = 40 \text{ C}$$

14. Question

What is the current in a circuit if the charge passing each point is 20 C in 40 s ?

Answer

Here charge =20 C and time = 40 sec

$$I = \frac{q}{t} = \frac{20}{40} = 0.5 \text{ A}$$

15. Question

Fill in the following blanks with suitable words :

- (a) A current is a flow ofFor this to happen there must be acircuit.
(b) Current is measured in..... using an placed in in a circuit.

Answer

(a) Electric current is carried by moving electrons through a conductor. Electric circuit is a continuous and closed path of electric current.

(b) Current is measured in ampere using an ammeter placed in series in a circuit.

Short Answer Type Questions-Pg-11

16 A. Question

Name a device which helps to maintain potential difference across a conductor (say, a bulb).

Answer

A source of electricity such as cell, battery, power supply, etc. helps to maintain a potential difference across a conductor.

16 B. Question

If a potential difference of 10 V causes a current of 2 A to flow for 1 minute, how much energy is transferred?

Answer

As we know that

$$Q = I \times t$$

Here $I = 2 \text{ A}$ and $T = 1 \text{ minute} = 60 \text{ sec}$

Thus $Q = 120 \text{ C}$

Again as we know

$$V = W/Q$$

$$W = VQ$$

$$W = 10 \times 120 = 1200 \text{ joule}$$

17 A. Question

What is an electric current? What makes an electric current flow in a wire?

Answer

The flow of electric charge is known as electric current. Electric current is carried by moving electrons through a conductor. It is the potential difference between the ends of the wire which make the electric charge (or current) to flow in the wire.

17 B. Question

Define the unit of electric current (or Define ampere).

Answer

SI unit of electric current is ampere (A). Ampere is the flow of electric charges through a surface at the rate of one coulomb per second.

18. Question

What is an ammeter? How is it connected in a circuit? Draw a diagram to illustrate your answer.

Answer

An ammeter is an apparatus which is used to measure electric current in a circuit. An ammeter is always connected in series with the circuit in which the current is to be measured.

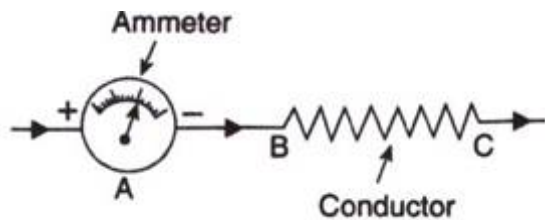

19 A. Question

Write down the formula which relates electric charge, time and electric current.

Answer

The equation below shows the relationship between charge, current and time: charge (coulomb, C) = current (ampere, A) × time

$$Q = I \times t$$

19 B. Question

A radio set draws a current of 0.36 A for 15 minutes. Calculate the amount of electric charge that flows through the circuit.

Answer

Here $I = 0.36 \text{ A}$

Time = 15 minute = $15 \times 60 = 900 \text{ sec}$

So Charge = $0.36 \times 900 = 324 \text{ C}$

20. Question

Why should the resistance of :

- (a) an ammeter be very small?
- (b) a voltmeter be very large?

Answer

(a) An ammeter has to measure to current flowing through the circuit. Resistance offers an obstruction to the current flow. So, if the resistance of an ammeter is large, the current measured by the ammeter will be quite less as compared to the actual amount of current flowing through the circuit which is undesirable. If ammeter has zero resistance, then it will give the exact value of current. But this is not practically possible because every material has some value of internal resistance which we can't control. For this reason, ammeter must have small resistance.

(b) If current is flowing through the voltmeter, then it is not all flowing through the load, and the potential difference across the load would change when the voltmeter is added and removed. This is unfavourable. Therefore, the voltmeter must have a very high resistance so that current doesn't flow through it.

21. Question

Draw circuit symbols for (a) fixed resistance (b) variable resistance (c) a cell (d) a battery of three cells (e) an open switch (j) a closed switch.

Answer

(a) Fixed resistance



(b) Variable resistance

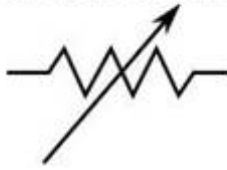

(c) Cell



(d) Battery of three cells



(e) Open switch



(f) Closed switch



22. Question

What is a circuit diagram? Draw the labelled diagram of an electric circuit comprising of a cell, a resistor, an ammeter, a voltmeter and a closed switch (or closed plug key). Which of the two has a large resistance: an ammeter or a voltmeter?

Answer

Electric circuit is represented by drawing circuit diagrams. A diagram which indicates how different components in a circuit have been connected by using the electrical symbols for the components is called a circuit diagram.

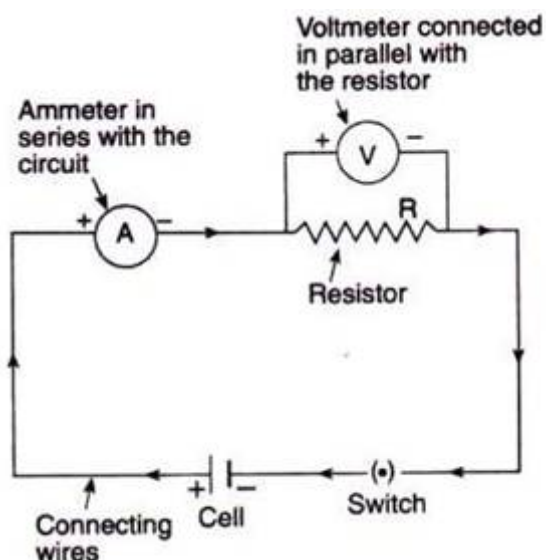

Voltmeter is an apparatus used to measure the potential difference or electric potential difference between two points in an electric circuit. A voltmeter has a large resistance.

23. Question

If the charge on an electron is 1.6×10^{-19} coulombs, how many electrons should pass through a conductor in 1 second to constitute 1-ampere current?

Answer

We know that charge over 1 electron = 1.6×10^{-19} coulomb

Thus, 1.6×10^{-19} C of charge = 1 electron

Therefore, 1 C of charge

$$= \frac{1}{1.6 \times 10^{-19}} \text{ electrons}$$

$$= \frac{10^{19}}{1.6} \text{ electrons}$$

$$= \frac{10 \times 10^{18}}{1.6} \text{ electrons}$$

$$= 6.25 \times 10^{18} \text{ electrons}$$

24. Question

The p.d. across a lamp is 12 V. How many joules of electrical energy are changed into heat and light when:

- (a) a charge of 1 C passes through it?
- (b) a charge of 5 C passes through it?
- (c) a current of 2 A flows through it for 10 s?

Answer

As we know that

Work done = potential difference x charge

a) $W = 12 \times 1 = 12 \text{ j}$

b) $W = 12 \times 5 = 60 \text{ j}$

c) $W = 12 \times 2 \times 10 = 240 \text{ j}$

25. Question

In 10 s, a charge of 25 C leaves a battery, and 200 J of energy are delivered to an outside circuit as a result.

- (a) What is the p.d. across the battery?
- (b) What current flows from the battery?

Answer

(a) As we know that

$$\text{Potential difference} = \frac{\text{Work done}}{\text{Charge}} = \frac{200}{25} = 8 \text{ V}$$

$$(b) \text{ Current} = \frac{\text{charge}}{\text{time}} = \frac{25}{10} = 2.5 \text{ A}$$

Long Answer Type Questions-Pg-12**26 A. Question**

Define electric current. What is the SI unit of electric current.

Answer

The flow of electric charge is known as electric current. Electric current is carried by moving electrons through a conductor. SI unit of electric current is ampere (A).

26 B. Question

One coulomb of charge flows through any cross-section of a conductor in 1 second. What is the current flowing through the conductor?

Answer

One coulomb is nearly equal to 6×10^{18} electrons. SI unit of electric current is ampere (A). Ampere is the flow of electric charges through a surface at the rate of one coulomb per second. This means if 1 coulomb of electric charge flows through a cross section for 1 second, it would be equal to 1 ampere.

26 C. Question

Which instrument is used to measure electric current? How should it be connected in a circuit?

Answer

An ammeter is an apparatus which is used to measure electric current in a circuit. It should be connected in series with the circuit.

26 D. Question

What is the conventional direction of the flow of electric current? How does it differ from the direction of flow of electrons?

Answer

The direction of an electric current is by convention the direction in which a positive charge would move. Thus, the current in the external circuit is directed away from the positive terminal and toward the negative terminal of the battery. Electrons would actually move through the wires in the opposite direction i.e from negative terminal to positive terminal.

26 E. Question

A flash of lightning carries 10 C of charge which flows for 0.01 s. What is the current? If the voltage is 10 MV, what is the energy?

Answer

Here

Charge, $Q = 10\text{C}$

Voltage = 10 MV = $10 \times 10^6\text{V}$

Energy of the charge particle is given by

$$E = Q V$$

$$= 10 \times 10 \times 10^6$$

$$= 10^8 \text{ J}$$

Multiple Choice Questions (MCQs)-Pg-12

27. Question

The other name of potential difference is :

- A. ampereage
- B. wattage
- C. voltage
- D. potential energy

Answer

Electric potential difference is known as voltage, which is equal to the work done per unit charge to move the charge between two points against static electric field. It is denoted by 'V'.

28. Question

Which statement/statements is/are correct?

1) An ammeter is connected in series in a circuit and a voltmeter is connected in parallel.

2) An ammeter has a high resistance.

3) A voltmeter has a low resistance.

A. 1, 2, 3

B. 1, 2

C. 2, 3

D. 1

Answer

An ammeter has to measure the current flowing through the circuit. Resistance offers an obstruction to the current flow. So, if the resistance of an ammeter is large, the current measured by the ammeter will be quite less as compared to the actual amount of current flowing through the circuit which is undesirable. If an ammeter has zero resistance, then it will give the exact value of current. But this is not practically possible because every material has some value of internal resistance which we can't control. For this reason, an ammeter must have small resistance.

29. Question

Which unit could be used to measure current?

- A. Watt
- B. Coulomb
- C. Volt
- D. Ampere

Answer

SI unit of electric current is ampere (A).

30. Question

If the current through a flood lamp is 5 A, what charge passes in 10 seconds?

- A. 0.5 C
- B. 2 C
- C. 5 C
- D. 50 C

Answer

Charge = Current \times time = 10 \times 5 = 50

31. Question

If the amount of electric charge passing through a conductor in 10 minutes is 300 C, the current flowing is :

- A. 30 A
- B. 0.3 A
- C. 0.5 A
- D. 5 A

Answer

Charge = Current \times time

$$\text{Current} = \frac{\text{Charge}}{\text{time}} = \frac{300}{10 \times 60} = 0.5 \text{ A}$$

Questions Based on High Order Thinking Skills (HOTS)-Pg-12

32. Question

A student made an electric circuit shown here to measure the current through two lamps.

- A. Are the lamps in series or parallel?
- B. The student has made a mistake in this circuit.

What is the mistake?

- C. Draw a circuit diagram to show the correct way to connect the circuit.

Use the proper circuit symbols in your diagram.

Answer

(a) The lamps are connected in series. In a series circuit, every device must function for the circuit to be complete.

(b) Here the students connected Ammeter in parallel with the lamps. An ammeter is always connected in series.

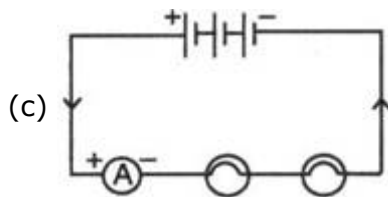

33. Question

Draw a circuit diagram to show how 3 bulbs can be lit from a battery so that 2 bulbs are controlled by the same switch while the third bulb has its own switch.

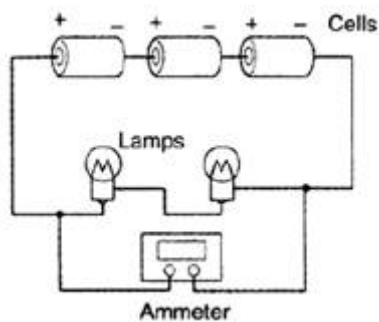

Answer

Two bulbs are connected in series, so that both bulbs are controlled by same switch and the third bulb is connected in parallel, so that it can be controlled by another switch.

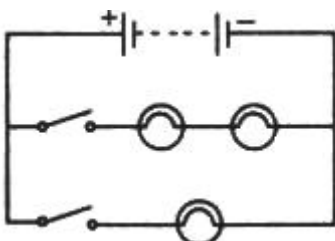

34. Question

An electric heater is connected to the 230 V mains supply. A current of 8A flows through the heater.

- (a) How much charge flows around the circuit each second?
(b) How much energy is transferred to the heater each second?

Answer

(a) Here Potential difference = 230 V

Current = 8A

Time = 1 Second

As we know that

The flow of electric charge per unit time is known as electric current.

$$\text{Current } (I) = \frac{\text{Charge } (Q)}{\text{Time } (t)}$$

$$\text{Charge } (Q) = \text{Current } (I) \times \text{Time } (t) = 8 \times 1 = 8C$$

So in each second the amount of charge flowing in the circuit is 8 C.

(b) As we know that the work done is equal to the amount of energy transferred in a circuit.

Electric potential difference is known as voltage, which is equal to the work done per unit charge to move the charge between two points against static electric field.

$$\text{So, Potential difference} = \frac{\text{Work done}}{\text{Charge moved}}$$

$$230V = \frac{\text{Work done}}{8}$$

$$\text{So, Work done} = 230 \times 8 = 1840 \text{ J}$$

It is also equal to the total energy transferred to the heater in each second

35. Question

How many electrons are flowing per second past a point in a circuit in which there is a current of 5 amp ?

Answer

$$\text{Here } I = \frac{Q}{t}$$

$$Q = I \times t$$

As we know that

$$Q = ne$$

$$Ne = I \times t$$

$$n = \frac{I \times t}{e}$$

$$n = \frac{5 \times 1}{1.6 \times 10^{19}} = 31.25 \times 10^{18}$$

Very Short Answer Type Questions-Pg-18

1. Question

Name the law which relates the current in a conductor to the potential difference across its ends.

Answer

The law stating that the direct current flowing in a conductor is directly proportional to the potential difference between its ends. It is usually formulated as $V = IR$. This law is called Ohm's law.

2. Question

Name the unit of electrical resistance and give its symbol.

Answer

The ohm (symbol: Ω) is the SI derived unit of electrical resistance, named after German physicist Georg Simon Ohm.

3. Question

Name the physical quantity whose unit is "ohm".

Answer

The ohm (symbol: Ω) is the SI derived unit of electrical resistance.

4. Question

What is the general name of the substances having infinitely high electrical resistance?

Answer

Substances having infinite resistivity are called insulators Ex: wood.

5. Question

Keeping the resistance constant, the potential difference applied across the ends of a component is halved.

By how much does the current change?

Answer

As we know that

$$V = IR$$

$$\text{So } I = \frac{V}{R}$$

As Current is directly proportional to potential difference

So Current is also become half

6. Question

State the factors on which the strength of electric current flowing in a given conductor depends.

Answer

The strength of electric current flowing in a given conductor depends upon the potential difference and resistance of the conductor.

7. Question

Which has less electrical resistance: a thin wire or a thick wire (of the same length and same material) ?

Answer

The larger the cross sectional area, the lower the resistance since the electrons have a larger area to flow through.

8. Question

Keeping the potential difference constant, the resistance of a circuit is halved. By how much does the current change?

Answer

As we know that

$$V = IR$$

As current is directly proportional to potential difference and inversely proportional to the resistance of the conductor. If resistance of a circuit is halved then the current will double.

9. Question

A potential difference of 20 volts is applied across the ends of a resistance of 5 ohms. What current will flow in the resistance?

Answer

As we know that

$$V = IR$$

$$I = \frac{V}{R} = \frac{20V}{5\Omega} = 4 \text{ ohms}$$

10. Question

A resistance of 20 ohms has a current of 2 amperes flowing in it. What potential difference is there between its ends?

Answer

As we know that

$$V = IR$$

$$V = 2A \times 20 \text{ ohms} = 40 \text{ V}$$

11. Question

A current of 5 amperes flows through a wire whose ends are at a potential difference of 3 volts. Calculate the resistance of the wire.

Answer

As we know that

$$V = IR$$

$$R = \frac{V}{I} = \frac{3}{5} = 0.6 \text{ ohms}$$

12. Question

Fill in the following blank with a suitable word :

Ohm's law states a relation between potential difference and

Answer

Ohm's law states a relation between potential difference and current.

Short Answer Type Questions-Pg-18**13. Question**

Distinguish between good conductors, resistors and insulators. Name two good conductors, two resistors and two insulators.

Answer

On the basis of their electrical resistance, all the substance can be divided into three groups they are Good conductors, Resistors and Insulators.

Those substances which have very low electrical resistance are called as good conductors. A good conductor allows the electricity to flow through it easily. Silver is the best conductor of electricity. Copper and aluminum are also good conductors.

Those substances which have comparatively high resistance than conductors are known as resistors. The alloys like nichrome, manganin and constantan, all have quite high resistance, so these are resistors.

Those substances which have infinitely high electrical resistance are called insulators. E.g- rubber and wood.

14. Question

Classify the following into good conductors, resistors and insulators:

Rubber, Mercury, Nichrome, Polythene, Aluminium, Wood, Manganin, Bakelite, Iron, Paper, Thermocol, Metal coin

Answer

Those substances which have very low electrical resistance are called as good conductors like mercury, aluminum, iron, metal coin.

Those substances which have comparatively high resistance than conductors are known as resistors. The alloys like nichrome, manganin.

Those substances which have infinitely high electrical resistance are called insulators like rubber, polythene, wood, bakelite, paper, thermocol

15. Question

What is Ohm's law? Explain how it is used to define the unit of resistance.

Answer

Ohm's law states that the current through a conductor between two points is directly proportional to the voltage across the two points. Introducing the constant of proportionality, the resistance, one arrives at the usual mathematical equation that describes this relationship

$$I = V R$$

Where I is the current through the conductor in units of amperes, V is the voltage measured across the conductor in units of volts, and R is the resistance of the conductor in units of ohms. More specifically, Ohm's law states that the R in this relation is constant, independent of the current.

One ohm is defined as the resistance of an object when a current of one ampere flows through a an object with a potential difference of one volt.

16 A. Question

What is meant by the "resistance of a conductor"? Write the relation between resistance, potential difference and current.

Answer

The resistance of a conductor is the ratio of potential difference between the ends of a conductor to the current flowing through it, or the property of a conductor due to which it opposes the flow of current through it is called resistance of the conductor.

$$\text{Potential differences}(V) = \text{Current } (I) \times \text{Resistance}(R)$$

16 B. Question

When a 12 V battery is connected across an unknown resistor, there is a current of 2.5 mA in the circuit. Calculate the value of the resistance of the resistor.

Answer

$$\text{According to Question, } V = 12\text{volt } I = 2.5\text{mA} = 2.5 \times 10^{-3}\text{A}$$

According to Ohms Law

$$\mathbf{V=IR}$$

$$\therefore R = \frac{V}{I} = \frac{12}{2.5 \times 10^{-3}} = 4800 \text{ ohm}$$

17 A. Question

Define the of resistance (or Define the unit "ohm").

Answer

The ohm is defined as a resistance between two points of a conductor when a constant potential difference of 1.0 volt, applied to these points, produces in the conductor a current of 1.0 ampere, the conductor not being the seat of any electromotive force.

17 B. Question

What happens to the resistance as the conductor is made thinner?

Answer

The resistance of the wire will increase if we made the conductor thinner because ρ (rho). | R (resistance) = $\frac{\rho \times l}{A}$. Area is directly proportional to the radius of the wire.

17 C. Question

Keeping the potential difference constant, the resistance of a circuit is doubled. By how much does the current changes?

Answer

As we know that

$$V = IR$$

$$\text{So, } I = V/R$$

According to the questions

$$V = I'2R$$

$$\text{So, } I' = V/2R$$

$$I' = I/2$$

So current become half

18 A. Question

Why do electricians wear rubber hand gloves while working with electricity ?

Answer

Rubber is an insulator and does not allow the passage of electric current through it, so when electricians wear rubber gloves electric current cannot pass through them, so they don't get shock.

18 B. Question

What p.d. is needed to send a current of 6 A through an electrical appliance having a resistance of 40 Ω

Answer

As we know that

$$V = IR$$

Here $I = 6\text{A}$, $R = 40\Omega$

So $V = 6 \times 40 = 240\text{V}$

19. Question

An electric circuit consisting of a 0.5 m long nichrome wire XY, an ammeter, a voltmeter, four cells of 1.5 V each and a plug key was set up.

(i) Draw a diagram of this electric circuit to study the relation between the potential difference maintained between the points 'X' and 'Y' and the electric current flowing through XY.

(ii) Following graph was plotted between V and I values:

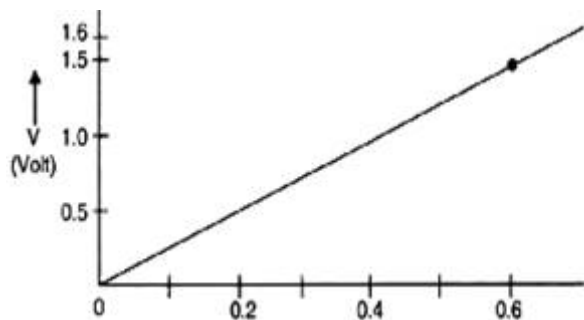

What would be the value of $\frac{V}{I}$ ratios when the potential differences are 0.8 V, 1.2 V and 1.6 V respectively?

What conclusion do you draw from the values?

(iii) What is the resistance of the wire?

Answer

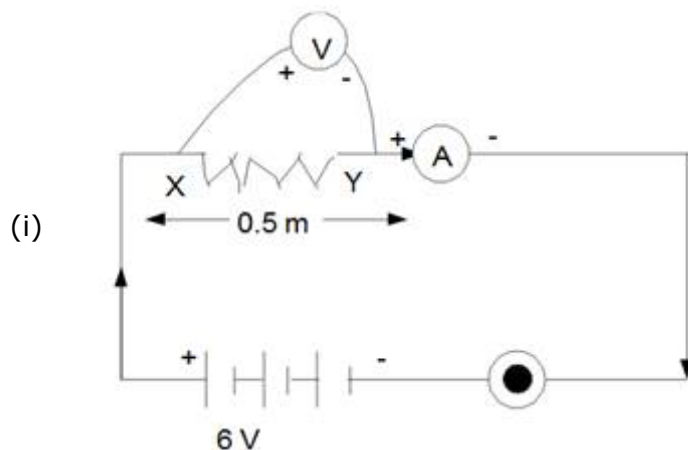

(ii) From graph we find that current values corresponding to potential difference of 0.8V, 1.2V and 1.6V respectively are 0.3 A, 0.45A and 0.6A.

$\frac{V}{I}$ ratios are

$$\frac{0.8V}{0.3A} = 2.67\Omega$$

$$\frac{1.2V}{0.45A} = 2.67\Omega$$

$$\frac{1.6V}{0.6A} = 2.67\Omega$$

From these values we conclude that ratio V/I is a constant i.e., $V \propto I$. It means that Ohm's law is being followed.

(iii) The resistance of the wire is equal to the ratio of potential difference applied and the current passing through it.

$$R = \frac{V}{I} = 25\Omega$$

Long Answer Type Questions-Pg-19

20 A. Question

What is the ratio of potential difference and current known as?

Answer

Resistance is the ratio of potential difference across a component to the current flowing through it, it is measure in ohms.

20 B. Question

The values of potential difference V applied across a resistor and the corresponding values of current I flowing in the resistor are given below :

Potential difference, V (in volts):	2.5	5.0	10.0	15.0	20.0	25
Current, I (in amperes)	0.1	0.2	0.4	0.6	0.8	1.0

Plot a graph between V and I , and calculate the resistance of the resistor.

Answer

The plot between voltage and current is called IV characteristics. The voltage is plotted on y- axis. The values of the current for different values of the voltage are shown in the given table

The plot between voltage and current is called IV characteristic. The voltage is plotted on x-axis and current is plotted on y-axis. The values of the current for different values of the voltage are shown in the given table

Potential(V)	2.5	5.0	10.0	15.0	20.0	25.0
Current (I)	0.1	0.2	0.4	0.6	0.8	1.0

20 C. Question

Name the law which illustrated by the above V-I graph.

Answer

From these values we conclude that ration V/I is a constant i.e., $V \propto I$. It means that Ohm's law is being followed.

20 D. Question

Write down the formula which states the relation between potential difference, current and resistance.

Answer

The formula is given by Ohm which states the relation between potential difference, current and resistance.

Potential difference = Current \times Resistance

20 E. Question

The potential difference between the terminals of an electric iron is 240 V and the current is 5.0 A. What is the resistance of the electric iron?

Answer

Here, $V=240$ volt, $I= 5$ A, $R=?$ According to Ohms Law: $V= IR$ $R = \frac{V}{I} = \frac{240}{5} = 48\Omega$

Multiple Choice Questions (MCQs)-Pg-19

21. Question

The p.d. across a 3Ω resistor is 6 V. The current flowing in the resistor will be:

- A. $\frac{1}{2}$ A
- B. 1 A
- C. 2 A
- D. 6 A

Answer

As we know that

$$I = \frac{V}{R} = \frac{6V}{3\Omega} = 2A$$

22. Question

A car headlight bulb working on a 12 V car battery draws a current of 0.5 A. The resistance of the light bulb is:

- A. 0.5 Ω
- B. 6 Ω
- C. 12 Ω
- D. 24 Ω

Answer

As we know that

$$R = \frac{V}{I} = \frac{12V}{0.5} = 24\Omega$$

23. Question

An electrical appliance has a resistance of 25 Ω . When this electrical appliance is connected to a 230 V supply line, the current passing through it will be :

- A. 0.92 A
- B. 2.9 A
- C. 9.2 A
- D. 92 A

Answer

$$I = \frac{V}{R} = \frac{230V}{25\Omega} = 9.2A$$

24. Question

When a 4 Ω resistor is connected across the terminals of a 12 V battery, the number of coulombs passing through the resistor per second is :

- A. 0.3
- B. 3
- C. 4
- D. 12

Answer

R= 4 ohms

V= 12 V

I= 12/4 =3A

$$I=Q/t$$

$$Q=3 \text{ C}$$

25. Question

Ohm's law gives a relationship between:

- A. current and resistance
- B. resistance and potential difference
- C. potential difference and electric charge
- D. current and potential difference

Answer

Ohm's law gives a relationship between current and potential difference.

26. Question

The unit of electrical resistance is :

- A. ampere
- B. volt
- C. coulomb
- D. ohm

Answer

Ohm is the S.I unit of electrical resistance.

27. Question

The substance having infinitely high electrical is called:

- A. conductor
- B. resistor
- C. superconductor
- D. insulator

Answer

The substance having infinitely high electrical is called conductor.

28. Question

Keeping the potential difference constant, the resistance of a circuit is halved. The current will become:

- A. one-fourth
- B. four times
- C. half

D. double

Answer

Current is inversely proportional to resistance.

29. Question

Keeping the potential difference constant, the resistance of a circuit is halved. The current will become:

A. one-fourth

B. four times

C. half

D. double

Answer

Double

Questions Based on High Order Thinking Skills (HOTS)-Pg-20

30. Question

An electric room heater draws a current of 2.4 A from the 120 V supply line. What current will this room heater draw when connected to 240 V supply line?

Answer

$$I=2.4A$$

potential difference = 120V:

$$R= V/I$$

$$R= 120/2.4 =50 \text{ ohms}$$

Since resistance remains constant therefore if potential difference = 240V

$$\text{then, } I= V/R = 240/50 = 4.8A$$

31. Question

Name the electrical property of a material whose symbol is "omega".

Answer

The electrical property of a material whose symbol is "omega is resistance.

32. Question

The graph between V and I for a conductor is a straight line passing through the origin.

(a) Which law is illustrated by such a graph?

(b) What should remain constant in a statement of this law?

Answer

(a) The I-V graph of the metallic conductor is a straight line pass through the origin. They obey Ohm's Law, having a resistance that is independent of current. (Ohmic conductors). The variation of current vs voltage is shown below:

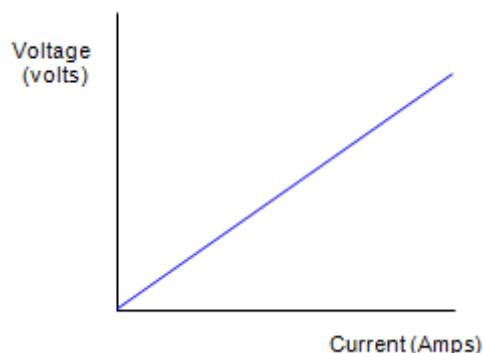

(b) Temperature remains constant in ohms law.

33. Question

A p.d. of 10 V is needed to make a current of 0.02 A flow through a wire. What p.d. is needed to make a current of 250 mA flow through the same wire?

Answer

Here $I_1 = 0.02$ amp, $V_1 = 10$ volt

$$V=IR$$

$$R = \frac{V}{I} = \frac{10}{0.02} = 500\Omega$$

Again

Here $I_2 = 250\text{mA}=0.25\text{A}$, $R = 500\Omega$

$$V_2=I_2R =0.25\times 500=125\text{V}$$

34. Question

A current of 200 mA flows through a 4 K Ω resistor. What is the p.d. across the resistor?

Answer

Given,

$$I = 200\text{mA} = 200 \times 10^{-3}\text{A}$$

$$R = 4000 \text{ ohms}$$

$$\text{So, } V = 200 \times 10^{-3}\text{A} \times 4 \times 10^3$$

$$V= 800 \text{ volts}$$

Very Short Answer Type Questions-Pg-26

1. Question

What happens to the resistance as the conductor is made thicker?

Answer

The resistance of the wire will decrease if we made the conductor thicker because R (resistance) = ρ (rho) \cdot l (length) / A (area of cross-section or thickness of wire). Area is directly proportional to the radius of the wire.

2. Question

If the length of a wire is doubled by taking more of wire, what happens to its resistance?

Answer

As the resistance of a wire is directly proportional to length of the conducting wire. If its length is doubled resistance also doubled.

3. Question

On what factors does the resistance of a conductor depend?

Answer

There are four factors that influence the resistance in a conductor. Thickness (cross sectional area of the wire), length, and temperature. The fourth factor is the conductivity of the material that is used.

4. Question

Name the material which is the best conductor of electricity.

Answer

Silver is the best conductor of electricity.

5. Question

Which among iron and mercury is a better conductor of electricity?

Answer

Mercury is a better conductor than iron as it has lower resistivity than iron.

6. Question

Why are copper and aluminium wires usually used for electricity transmission?

Answer

Copper and aluminium wires usually used for electricity transmission because copper and aluminium are very good conductors of electricity having very low electric resistivity (or resistance).

7. Question

Name the material which is used for making the heating element of an electric iron.

Answer

Nichrome wire is used as a heating element because it is very stable, even at high temperatures.

8. Question

What is nichrome? State its one use.

Answer

Nichrome (NiCr, nickel-chrome, chrome-nickel, etc.) generally refers to any alloy of nickel, chromium, and often iron and/or other elements or substances. Nichrome alloys are typically used in resistance wire. They are also used in some dental restorations (fillings) and in other applications.

9. Question

Give two reasons why nichrome alloy is used for making the heating elements of electrical appliances.

Answer

Firstly nichrome is an alloy, it has a higher resistivity and consequently a higher resistance. Therefore, it will resist the flow of charges more and lead to development of heat faster.

Secondly alloys like nichrome don't oxidise, i.e. burn easily at high temperatures.

10. Question

Why are the coils of electric irons and electric toasters made of an alloy rather than a pure metal?

Answer

The resistivity of an alloy is generally higher than that of its constituent metals. Alloys do not oxidise readily at high temperatures.

11. Question

Which has more resistance:

(a) a long piece of nichrome wire or a short one?

(b) a thick piece of nichrome wire or a thin piece?

Answer

(a) The resistance of a wire depends on its dimensions as well as on the conducting ability of the material from which it is made. A long wire has more resistance than a short one.

(b) A thin wire has more resistance than a thick one.

12 A. Question

How does the resistance of a pure metal change if its temperature decreases?

Answer

If temperature of a metal decrease the resistance will also decrease.

12 B. Question

How does the presence of impurities in a metal affect its resistance?

Answer

The presence of impurities in a metal increase the resistance of the metal.

13. Question

Fill in the following blanks with suitable words :

Resistance is measured in The resistance of a wire increases as the length; as the temperature; and as the cross-sectional area

Answer

Resistance is measured in **Ohms**. The resistance of a wire increases as the length **increases**, as the temperature **increases**, and as the cross-sectional area **decreases**.

Short Answer Type Questions-Pg-26

14 A. Question

What do you understand by the "resistivity" of a substance?

Answer

The electrical resistivity of a material is also known as its specific electrical resistance. It is a measure of how strongly a material opposes the flow of electric current. A definition of resistivity is the electrical resistance per unit length and per unit of cross-sectional area.

14 B. Question

A wire is 1.0 m long, 0.2 mm in diameter and has a resistance of 10Ω. Calculate the resistivity of its material?

Answer

Given:

The length of the wire, $l=1\text{m}$.

Diameter of wire, $D = 0.2\text{mm}$

∴ Radius of Wire, $r=0.1\text{mm}= 0.1\times 10^{-3}\text{m}$

Mathematically, the resistivity is defined as

$$\begin{aligned} R &= \frac{\rho l}{A} = \frac{\rho l}{\pi r^2} = \frac{R\pi r^2}{l} \\ &= \frac{10 \times 3.14 \times (0.1 \times 10^{-3})^2}{1} \\ &= 0.314 \times 10^{-6} \Omega m \end{aligned}$$

15 A. Question

Write down an expression for the resistance of a metallic wire in terms of the resistivity.

Answer

Resistance of a metallic wire with resistivity ρ of length l and cross sectional area A is

$$R = \frac{\rho l}{A}$$

15 B. Question

What will be the resistance of a metal wire of length 2 metres and area of cross-section $1.55 \times 10^{-6} \text{ m}^2$, if the resistivity of the metal be $2.8 \times 10^{-8} \Omega \text{ m}$?

Answer

$$R = \frac{\rho l}{A} = \frac{(2.8 \times 10^{-8}) \times 2}{(1.55 \times 10^{-6})} \approx 0.036 \Omega$$

16 A. Question

Give two examples of substances which are good conductors of electricity. Why do you think they are good conductors of electricity?

Answer

Metals are typically good conductors because of their ability to donate electrons. Most metal atoms have one or two valence electrons, which means that they want to give these away in order to become more stable. Silver and copper are good conductors of electricity because they have free electrons available for conduction.

16 B. Question

Calculate the resistance of a copper wire 1.0 km long and 0.50 mm diameter if the resistivity of copper is $1.7 \times 10^{-8} \Omega \text{ m}$.

Answer

According to Question,

Length of Wire = 1 km = 1000 m

Diameter of Wire = 0.50 mm

\therefore Radius of wire = 0.25 mm = $0.25 \times 10^{-3} \text{ m}$

Resistivity (ρ) = $1.7 \times 10^{-8} \Omega \text{ m}$

$$R = \frac{\rho l}{A} = \frac{\rho l}{\pi r^2} = \frac{1.7 \times 10^{-8} \times 1000}{3.14 \times 0.00025^2} = 86.6 \text{ ohm}$$

17. Question

Will current flow more easily through a thick wire or a thin wire of the same material when connected to the same source? Give reason for your answer.

Answer

The current will flow more easily through thick wire. It is because the resistance of a conductor is inversely proportional to its area of cross-section. If thicker the wire, less is resistance and hence more easily the current flows.

18. Question

How does the resistance of a conductor depend on :

- (a) length of the conductor?
- (b) area of cross-section of the conductor?
- (c) temperature of the conductor?

Answer

- a) Resistance of a conductor is directly proportional to the length of conductor.
- b) Resistance of a conductor is inversely proportional to the area of cross section of the conductor.
- c) Resistance of a conductor depends upon the nature of the material of the conductor. Resistance of a conductor increases on raising the temperature and decreases on lowering the temperature.

19 A. Question

Give one example to show how the resistance depends on the nature of material of the conductor.

Answer

If we connect different type of wire (nichrome, copper etc) in ac ircuit made using a battery, ammeter. We will see that the ammeter shows different reading in each case i.e. resistance differs as nature of material changes.

19 B. Question

Calculate the resistance of an aluminium cable of length 10 km and diameter 2.0 mm if the resistivity of aluminium is $2.7 \times 10^{-8} \Omega\text{m}$.

Answer

Length of the cable is $L = 10 \text{ km} = 10^4 \text{ m}$
Diameter of cable is $d = 2 \text{ mm}$
Hence, radius is $r = 1 \text{ mm} = 1 \times 10^{-3} \text{ m}$
Resistivity of Aluminium is $\rho = 2.7 \times 10^{-8} \Omega\text{m}$

We know that resistance of a wire is given as

$$R = \frac{\rho l}{A} = \frac{\rho l}{\pi r^2}$$
$$\therefore R = \frac{2.7 \times 10^{-8} \times 10^4}{3.14 \times (1 \times 10^{-3})^2} = \frac{2.7 \times 10^{-4}}{3.14 \times 10^{-6}} = 86 \Omega$$

Hence, the resistance of the aluminium cable is 86Ω

20. Question

What would be the effect on the resistance of a metal wire of :

- (a) increasing its length?
- (b) increasing its diameter?

(c) increasing its temperature?

Answer

(a) The resistance of a metal wire will increase as it is directly proportional to length.

(b) The resistance of a metal wire decrease as it is inversely proportional to the area of the wire.

(c) Resistance of a conductor depends upon the nature of the material of the conductor. Resistance of a conductor increases on raising the temperature and decreases on lowering the temperature

21. Question

How does the resistance of a wire vary with its :

(a) area of cross-section?

(b) diameter?

Answer

(a) The resistance of a metal wire is inversely proportional to the area of the wire, so if the area increase resistance decrease.

(b) If diameter increase than area increase and the resistance decreases.

22. Question

How does the resistance of a wire change when:

(i) its length is tripled?

(ii) its diameter is tripled?

(iii) its material is changed to one whose resistivity is three times?

Answer

(i) The resistance of a wire is directly proportional to its length and inversely proportional to its area (or square of inverse of diameter). When the length is tripled then its resistance will also becomes three times

(ii) If the diameter get tripled then its resistance becomes one ninth of the initial resistance.

(iii) If the material is changed to one whose resistivity is three times then again its resistance will be three times

23. Question

Calculate the area of cross section of a wire if its length is 1.0 m, its resistance is 23Ω and the resistivity of the material of the wire is $1.84 \times 10^{-6} \Omega\text{m}$.

Answer

Here length of the wire = 1 m

Resistance of the wire = 23 ohms

Resistivity of the wire = 1.84×10^{-6} ohm meter

As we know that

$$R = \frac{\rho l}{A}$$

$$A = \frac{\rho l}{R} = \frac{1.84 \times 10^{-6}}{23} = 8 \times 10^{-8} m^2$$

Long Answer Type Questions-Pg-27

24 A. Question

Define resistivity. Write an expression for the resistivity of a substance. Give the meaning of each symbol which occurs in it.

Answer

By definitions the resistivity of a material of a conductor is the resistance offered by a unit length and unit cross-section of the conductor. It is intrinsic property of material.

The expression for the resistivity is

$$\rho = \frac{m}{ne^2\tau}$$

Where m = mass of the electron

N = number density of electron

E = charge on the electron

T = relaxation time.

24 B. Question

State the SI unit of resistivity.

Answer

Resistivity is commonly represented by the Greek letter ρ (rho). The SI unit of electrical resistivity is the ohm-metre ($\Omega \cdot m$).

24 C. Question

Distinguish between resistance and resistivity.

Answer

The following points state the differences between Resistance and Resistivity:

	Resistivity	Resistance
1)	The resistivity of a material is the resistance of a wire of that material of unit length and unit cross-sectional area.	Resistance is the opposition to the flow of electric current in a substance.
2)	It is an intrinsic property	It is an extrinsic property
3)	The resistivity of a conductor is always same and is independent of its length or size.	The resistance of a conductor is dependent on its length or size.
4)	The unit of resistivity is ohm-metre	The unit of Resistance is ohm

24 D. Question

Name two factors on which the resistivity of a substance depends and two factors on which it does not depend.

Answer

Resistivity of a substance depends on the nature of the substance and its temperature. It does not depend on the length or thickness of the conductor.

24 E. Question

The resistance of a metal wire of length 1 m is 26Ω at 20°C . If the diameter of the wire is 0.3 mm, what will be the resistivity of metal at that temperature?

Answer

We know,

$$R = \frac{\rho \times l}{A}$$

$$\therefore \rho = \frac{R \times A}{l}$$

According to Question,

Length of the conductor(In this case wire) = 1m

Diameter of the wire= 0.3mm

$$\therefore \text{Radius of Wire} = \frac{0.30\text{mm}}{2} = 0.15\text{mm} = 0.15 \times 10^{-3}\text{m}$$

Resistance of the conductor(In this case wire)= 26Ω

$$\begin{aligned}\therefore \rho &= \frac{26\Omega \times \pi \times (0.15 \times 10^{-3}m)^2}{1m} \\ &= 1.84 \times 10^{-6}\Omega m\end{aligned}$$

Multiple Choice Questions (MCQs)-Pg-27

25. Question

The resistance of a wire of length 300 m and cross-section area 1.0 mm^2 made of material of resistivity $1.0 \times 10^{-7} \Omega \text{ m}$ is :

- A. 2Ω
- B. 3Ω
- C. 20Ω
- D. 30Ω

Answer

$$R = \frac{\rho l}{A}$$

26. Question

When the diameter of a wire is doubled, its resistance becomes:

- A. double
- B. four times
- C. one-half
- D. one-fourth

Answer

When the diameter of a wire is doubled, its resistance becomes one-fourth.

27. Question

If the resistance of a certain copper wire is 1Ω , then the resistance of a similar nichrome wire will be about:

- A. 25Ω
- B. 30Ω
- C. 60Ω
- D. 45Ω

Answer

Alloy of nickel, chromium, manganese and iron having a resistivity of about 60 times more than that of copper.

28. Question

If the diameter of a resistance wire is halved, then its resistance becomes:

- A. four times
- B. half
- C. one-fourth
- D. two times

Answer

If the diameter of a resistance wire is halved, then its resistance becomes four times.

29. Question

The resistivity of a certain material is $0.6 \Omega\text{m}$. The material is most likely to be:

- A. an insulator
- B. a superconductor
- C. a conductor
- D. a semiconductor

Answer

The resistivity of semiconductor like silicon and germanium is in between those of conductor and insulator.

30. Question

When the area of cross-section of a conductor is doubled, its resistance becomes:

- A. double
- B. half
- C. four times
- D. one-fourth

Answer

When the area of cross-section of a conductor is doubled, its resistance becomes

31. Question

The resistivity of copper metal depends on only one of the following factors. This factor is :

- A. length
- B. thickness
- C. temperature

D. area of cross-section

Answer

The resistivity of copper metal depends on temperature.

32. Question

If the area of cross-section of a resistance wire is halved, then its resistance becomes :

A. one-half

B. 2 times

C. one-fourth

D. 4 times

Answer

If the area of cross-section of a resistance wire is halved, then its resistance becomes twice.

Questions Based on High Order Thinking Skills (HOTS)-Pg-27

33. Question

A piece of wire of resistance 20Ω is drawn out so that its length is increased to twice its original length. Calculate the resistance of the wire in the new situation.

Answer

We know that

$$R = \rho \frac{l}{A} = 20 \Omega$$

Now if we stretch the same wire in such a way that its length get double. At the same time its area of cross-section decrease to half. So that

$$R' = \rho \frac{l}{A'} = \rho \frac{2l}{\frac{A}{2}} = 4\rho \frac{l}{A} = 4R = 80 \Omega$$

34. Question

The electrical resistivities of three materials P, Q and R are given below :

P $2.3 \times 10^3 \Omega \text{ m}$

Q $2.63 \times 10^{-8} \Omega \text{ m}$

R $1.0 \times 10^{15} \Omega \text{ m}$

Which material will you use making (a) electric wires (b) handle for soldering iron, and (c) solar cells? Give reasons for your choices.

Answer

(a) Material Q with resistivity 2.63×10^{-8} ohm-m can be used for making electric wires because it has very low resistivity.

(b) Material R with resistivity 1.0×10^{15} ohm-m can be used for making handle of soldering iron because it has very high resistivity.

(c) Material P with resistivity 2.3×10^3 ohm-m can be used for making solar cell because it is a semiconductor.

35. Question

The electrical resistivities of four materials A, B, C and D are given below :

A) $110 \times 10^{-8} \Omega \text{ m}$

B) $1.10 \times 10^{10} \Omega \text{ m}$

C) $01.0 \times 10^{-8} \Omega \text{ m}$

D) $2.3 \times 10^3 \Omega \text{ m}$

Which material is : (a) good conductor (b) resistor (c) insulator, and (d) semi-conductor ?

Answer

(a) Good conductor = C (10×10^{-8} ohm-m)

(b) Resistor = A (110×10^{-8} ohm-m)

(c) Insulator = B (1×10^{10} ohm-m)

(d) Semiconductor = D (2.3×10^3 ohm-m)

36. Question

The electrical resistivities of five substances A, B, C, D and E are given below :

A) $5.20 \times 10^{-8} \Omega \text{ m}$

B) $2.60 \times 10^{-8} \Omega \text{ m}$

C) $10.0 \times 10^{-8} \Omega \text{ m}$

D) $1.70 \times 10^{-8} \Omega \text{ m}$

(a) Which substance is the best conductor of electricity? Why?

(b) Which one is better conductor: A or C? Why?

(c) Which substance would you advice to be used for making heating elements of electric irons? Why?

(d) Which two substances should be used for making electric wires? Why?

Answer

(a) E is the best conductor of electricity due to its least electrical resistivity.

- (b) C, because its resistivity is lesser than that of A.
- (c) B, because it has highest electrical resistivity
- (d) C and E, because of their low electrical resistivities.

Very Short Answer Type Questions-Pg-37

1. Question

Give the law of combination of resistances in series.

Answer

When resistors are joined from end to end, it is called in series. In this case, the total resistance of the system is equal to the sum of the resistance of all the resistors in the system.

2. Question

If five resistances, each of value 0.2 ohm, are connected in series, what will be the resultant resistance?

Answer

According to the law of combination of series connection

We know that

$$R = R_1 + R_2 + R_3 + R_4 + R_5$$

$$R = 0.2 + 0.2 + 0.2 + 0.2 + 0.2 = 1\text{ohm}$$

3. Question

State the law of combination of resistances in parallel.

Answer

When resistors are joined in parallel, the reciprocal of total resistance of the system is equal to the sum of reciprocal of the resistance of resistors.

4. Question

If 3 resistances of 3 ohm each are connected in parallel, what will be their total resistance?

Answer

We know that in parallel combination, the reciprocal of total resistance is

$$\frac{1}{R} = \frac{1}{R_1} + \frac{1}{R_2} + \frac{1}{R_3}$$

$$\frac{1}{R} = \frac{1}{3} + \frac{1}{3} + \frac{1}{3} = 1\text{ohm}$$

5. Question

How should the two resistances of 2 ohms each be connected so as to produce an equivalent resistance of 1 ohm?

Answer

According to the question the resultant resistance is less than the individual resistances, so the resistances should be connected in parallel not in series.

6. Question

Two resistances X and Y are connected turn by turn : (i) in parallel, and (ii) in series. In which case the resultant resistance will be less than either of the individual resistance?

Answer

The resultant resistance will be less than either of the individual resistance in parallel connection.

7. Question

What possible values of resultant resistance one can get by combining two resistances, one of value 2 ohm and the other 6 ohm?

Answer

Here, $R_1=2$ ohm, $R_2=6$ ohm

When the resistors are arranged in parallel combination we get,

$$\frac{1}{R} = \frac{1}{2} + \frac{1}{6} = \frac{4}{6}$$

or $R = \frac{6}{4} = 1.5 \text{ ohms}$

Again, when the resistors are arranged in series combination we get

$$R = R_1 + R_2 = 2 + 6 = 8 \text{ ohm}$$

8. Question

Show how you would connect two 4 ohm resistors to produce a combined resistance of (a) 2 ohms (b) 8 ohms.

Answer

When two 4 ohm resistors are connected in parallel then the equivalent resistance will be

$$1/R_{\text{equivalent}} = 1/4 + 1/4 = 2/4 = 1/2$$

$$\text{Or } R = 2 \text{ ohms}$$

When two 4 ohm resistors are connected in series then the equivalent resistance will be

$$R_{\text{equivalent}} = 4 \text{ ohm} + 4 \text{ ohm} = 8 \text{ ohm}$$

9. Question

Which of the following resistor arrangement, A or B, has the lower combined resistance?

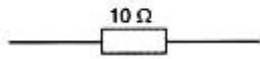

(A)

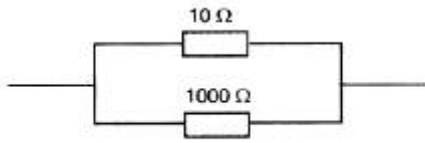

(B)

Answer

Equivalent resistance in arrangement A is 10 ohm as this is in series.

And in arrangement B both 10 ohm and 1000 ohm are in parallel.

So, combined resistance of arrangement B is calculated as follows:

$$1/R = 1/10 + 1/1000 = (100+1)/1000$$

$$R = 1000/101 = 9.9 \text{ ohm}$$

So, arrangement in B has lower combined resistance.

10. Question

A wire that has resistance R is cut into two equal piece. The two parts are joined in parallel. What is the resistance of the combination?

Answer

As the wire is cut into two equal pieces. So resistance of each part is R/2.

The two parts are joined in parallel. So the equivalent resistance will be

$$1/R_{\text{equivalent}} = 2/R + 2/R$$

$$1/R_{\text{equivalent}} = 4/R$$

$$R_{\text{equivalent}} = R/4$$

11. Question

Calculate the combined resistance in each case:



(a)

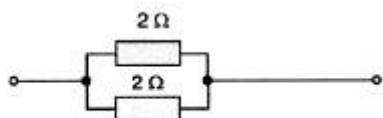

(b)

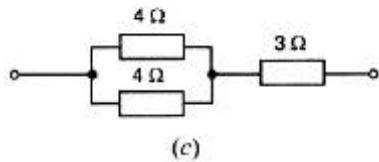

Answer

(a) Here both resistance i.e. $R_1 = 500 \text{ ohm}$, $R_2 = 1000 \text{ ohm}$ are connected in series
 So equivalent resistance $R = R_1 + R_2 = 500 + 1000 = 1500 \text{ohm}$.

(b) Here both resistance i.e. $R_1=2\text{ohm}$, $R_2=2\text{ohm}$ are connected in parallel
 So equivalent resistance

$$1/R=1/R_1+1/R_2$$

$$1/R=1/2+1/2$$

$$R=1\text{ohm}$$

(c) Here resistance $R_1=4\text{ohm}$ and $R_2=4\text{ohm}$ are in parallel and $R_3=3\text{ohm}$ are in series

According to the given figure,

$$1/R=1/R_1+1/R_2$$

$$1/R=1/4+1/4$$

$$R=2\text{ohm}$$

Total resistance of the given circuit $=R+R_3$

$$=2+3=5\text{ohm}$$

12. Question

Find the current in each resistor in the circuit shown below:

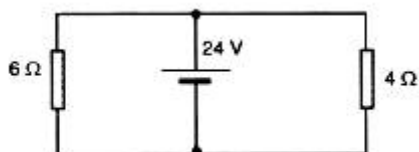

Answer

Let $R_1=6\Omega$, $R_2=4\Omega$ and $V=24V$

As the two resistances are connected in parallel. So the current across R_1 will be

$$I_1 = \frac{V}{R_1} = \frac{24}{6} = 4 \text{ ampere}$$

And the Current across R_2 will be

$$I_2 = \frac{V}{R_2} = \frac{24}{4} = 6 \text{ ampere}$$

Short Answer Type Questions-Pg-38

13. Question

Explain with diagrams what is meant by the "series combination" and "parallel combination" of resistances. In which case the resultant resistance is: (i) less, and (ii) more, than either of the individual resistances?

Answer

In a circuit, resistors are connected end-to-end are said to be in series, if the same current

exists in all of them through a single path. When resistances are connected in series, their equivalent resistance is equal to the sum of the individual resistances.

$$R = R_1 + R_2 + R_3 + \dots$$

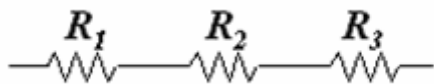

When resistances are connected in parallel, the reciprocal of their equivalent resistance is equal to the sum of the reciprocals of the individual resistances.

$$1/R = 1/R_1 + 1/R_2 + 1/R_3 + \dots$$

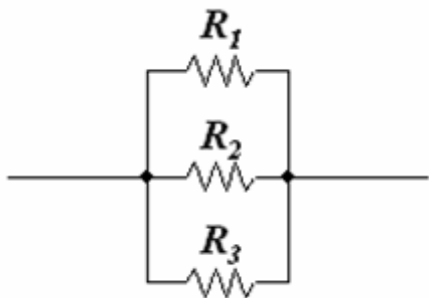

The resultant resistance is less than either of the individual resistances.

14. Question

A battery of 9 V is connected in series with resistors of 0.2 Ω, 0.3 Ω, 0.4 Ω, 0.5 Ω and 12 Ω. How much current would flow through the 12 Ω resistor?

Answer

Here a battery of 9 V is connected in series with resistors of R₁=0.2ohm, R₂=0.4ohm, R₃=0.3ohm, R₄=0.5ohm, R₅=12ohm,

So the resultant resistance = R₁ + R₂ + R₃ + R₄ + R₅

$$R = 0.2+0.4+0.3+0.5+12=13.4\text{ohm}$$

As we know that

$$V = IR$$

Thus the current flow through 12ohm resistance will be equal to the current flowing across the whole circuit as in case of Series Connection same current flows through each resistance

$$\therefore I = V/R$$

$$I = 9/13.4$$

$$I = 0.67\text{amp.}$$

15. Question

An electric bulb of resistance 20Ω and a resistance wire of 4Ω are connected in series with a 6 V battery. Draw the circuit diagram and calculate:

- (a) total resistance of the circuit
- (b) current through the circuit.
- (c) potential difference across the electric bulb.
- (d) potential difference across the resistance wire.

Answer

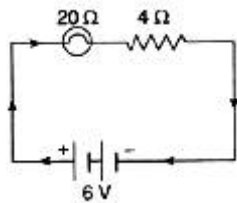

- (a) Here resistance are connected in series

$$\text{Total resistance of the circuit} = R_1 + R_2 = 20 + 4 = 24\Omega(\text{ohm})$$

- (b) According to ohm's law.

$$V = IR$$

Therefore,

$$6\text{V} = I \times 24\Omega(\text{ohm})$$

$$I = 6\text{ V} / 24\text{ ohm} = 0.25\text{A}(\text{Ampere})$$

- (c) Potential difference across the electric bulb

$$V_1 = IR_1 = 0.25 \times 20 = 5\text{V}$$

- (d) Potential difference across the resistance wire

$$V_2 = IR_2 = 0.25 \times 4 = 1\text{V}$$

16. Question

Three resistors are connected as shown in the diagram.

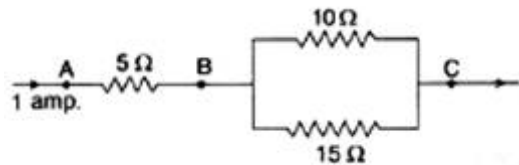

Through the resistor 5 ohm, a current of 1 ampere is flowing

- (i) What is the current through the other two resistors?
- (ii) What is the p.d. across AB and across AC?
- (iii) What is the total resistance?

Answer

(i) According to the figure.

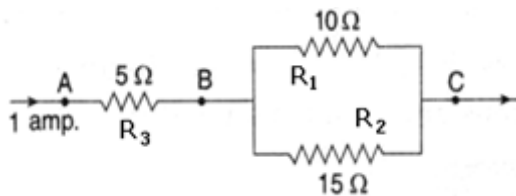

R_1 and R_2 are connected in parallel.

Let I be the current following in the circuit, which is equal to 1A. After passing through the resistance R_3

Current I is divided into two part say I_1 and I_2

$$I_1 = \frac{IR_2}{R_1 + R_2}$$

$$= \frac{1 \times 15}{10 + 15} = 0.6A$$

$$I_2 = \frac{IR_1}{R_1 + R_2}$$

$$= \frac{1 \times 10}{10 + 15} = 0.4A$$

(ii) Potential difference across AB = $IR_3 = 1 \times 5 = 5V$

As R_1 and R_2 are connected in parallel

So the equivalent resistance $1/R_{\text{equivalent}} = 1/R_1 + 1/R_2$

$$1/R_{\text{equivalent}} = 1/10 + 1/15$$

$$R_{\text{equivalent}} = 6 \text{ ohm}$$

Total resistance in the circuit

$$R_{\text{total}} = 5 + 6 = 11 \text{ ohm}$$

Potential difference across AC = $IR = 1 \times 11 = 11V$

17. Question

For the circuit shown in the diagram below:

What is the value of:

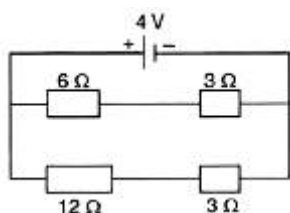

(i) current through 6 Ω resistor?

(ii) potential difference across 12 Ω resistor?

Answer

The resistance of 6 ohm and 3 ohm are connected in series. Therefore, their net resistance can be calculated as

$$R = R_1 + R_2$$

$$\text{Here, } R_1 = 6\text{ohm}$$

$$R_2 = 3\text{ohm}$$

$$\text{so } R = 6\text{ohm} + 3\text{ohm} = 9\text{ ohm}$$

The current through 6 ohm resistor = current through line 1 = $I = V/R = 4/9 = 0.44\text{V}$

(ii) The resistance of 12ohm and 3 ohm are connected in series. Therefore, their net resistance can be calculated as

$$R = R_1 + R_2$$

$$\text{Here, } R_1 = 12\text{ohm}$$

$$R_2 = 3\text{ohm}$$

$$\text{so } R = 12\text{ohm} + 3\text{ohm} = 15\text{ ohm}$$

The current through them = $I = V/R = 4/15$

Potential difference across 12 ohm resistor = $4/15 \times 12 = 3.2$

18. Question

Two resistors, with resistances 5 Ω and 10 Ω respectively are to be connected to a battery of emf 6 V so as to obtain:

(i) minimum current flowing

(ii) maximum current flowing

(a) How will you connect the resistances in each case?

(b) Calculate the strength of the total current in the circuit in the two cases.

Answer

(i) For obtaining minimum current, the two resistors should be connected in parallel.

(ii) For obtaining maximum current, the two resistors should be connected in series.

(a) $R_1 = 5 \text{ ohm}$, $R_2 = 10 \text{ ohm}$ and $V = 6 \text{ V}$

For parallel combination

$$\frac{1}{R} = \frac{1}{R_1} + \frac{1}{R_2}$$

$$\frac{1}{R} = \frac{1}{5} + \frac{1}{10}$$

$$R = 10/3 \text{ ohm}$$

Total current in the circuit

$$I = \frac{V}{R} = \frac{6 \times 3}{10} = 1.8 \text{ A}$$

For series combination

$$R = R_1 + R_2$$

$$R = 5 + 10 = 15 \text{ ohm}$$

Total current in the circuit.

$$I = \frac{V}{R} = \frac{6}{15} = 0.4 \text{ A}$$

(b) So the current in each case is 1.8 A and 0.4A in parallel and series circuit respectively.

19. Question

The circuit diagram given below shows the combination of three resistors R_1 , R_2 and R_3 :

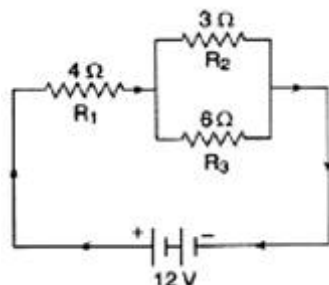

Find:

(i) total resistance of the circuit.

(ii) total current flowing in the circuit.

(iii) the potential difference across R_1 .

Answer

(i) As shown in the figure, the resistor R_2 and R_3 are connected in parallel. Their total resistance is given by

$$\frac{1}{R} = \frac{1}{R_2} + \frac{1}{R_3}$$

Here $R_2 = 3 \text{ ohm}$ and $R_3 = 6 \text{ ohm}$

$$\text{So } \frac{1}{R} = \frac{1}{3} + \frac{1}{6}$$

$R = 2 \text{ ohm}$

The resistance R_1 is in series with the equivalent resistance which are parallel.

Total resistance of the circuit = $2 + 4 \text{ ohms} = 6 \text{ ohms}$

(ii) Total current flowing through the circuit = Potential difference / total resistance

Here p.d = 12V , and total resistance = 6 ohms

$$I = 12/6 = 2 \text{ amps}$$

(iii) The potential difference across R_1 .

$$V = IR_1 = 2 \times 4 = 8 \text{V}$$

20. Question

In the circuit diagram given below, the current flowing across 5 ohm resistor is 1 amp . Find the current flowing through the other two resistors.

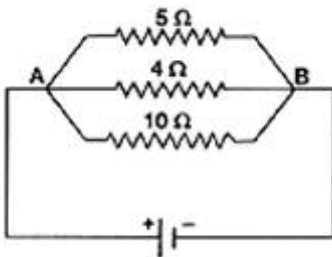

Answer

Given $I = 1 \text{ A}$ (Across 5 ohm)

$R = 5 \text{ ohm}$

The potential drop across AB, $V = I \times R$

$$\text{or } V = 5 \text{ ohm} \times 1 \text{ A} = 5 \text{V}$$

In a parallel circuit, the potential difference across the ends of all resistors remains the same. Therefore the potential difference across 4 ohm and 10 ohm will be 5 V

The current flowing through the 4 ohm resistance

$$= V/R = 5/4 = 1.25 \text{ A}$$

Current through 10 ohm resistor = $V/R = 5/10 = 0.5 \text{ A}$

21. Question

A resistor has a resistance of 176 ohms. How many of these resistors should be connected in parallel so that their combination draws a current of 5 amperes from a 220 volt supply line?

Answer

We know according to Ohms Law that: $V = IR$

Where $V =$ Voltage/Potential Difference $I =$ Current

$R =$ Resistance

According to Question : $V = 220\text{V}$

$I = 5\text{A}$

\therefore Total Resistance of the Combination is :- $\frac{V}{I} = \frac{220}{5} = 44\Omega$

Suppose x resistors should be connected in parallel to draw a current of 5A

for parallel combination:-

$\frac{1}{R} = \frac{1}{R_1} + \frac{1}{R_2} + \frac{1}{R_3} \dots \dots \frac{1}{R_x}$ (Where Resistance of each Resistor is 176Ω)

According to the question,

$R_{\text{Combination}} = 176/x \Rightarrow 44 = 176/x$ (We know from above the total resistance of combination)

$x = 176/44 = 4$ resistor Hence 4 resistors each of 176Ω should be connected in parallel so as to draw the current of 5A from a 220 volt supply line.

22. Question

An electric heater which is connected to 220 V supply line has two resistance coils A and B of 24Ω resistance each. These coils can be used separately (one at a time), in series or in parallel. Calculate the current drawn when:

- (a) only one coil A is used.
- (b) coils A and B are used in series
- (c) coils A and B are used in parallel.

Answer

(a) When only one coil, A is used

$V = IR$

$220 = 24I$

$I = 9.2$

(b) When coils A and B are used in series.

Total resistance $R = R_A + R_B = 24 + 24 = 48 \text{ohms}$

$$I = V/R = 220/48$$

=4.58amps

(c) When coils A and B are used in parallel.

$$\text{Total resistance} = \frac{1}{R} = \frac{1}{R_A} + \frac{1}{R_B}$$

$$\frac{1}{R} = \frac{1}{24} + \frac{1}{24} = \frac{1}{12}$$

$R = 12 \text{ohms}$

$$I = V/R = 220/12$$

=18.33amps

23. Question

In the circuit diagram given below five resistances of 10Ω , 40Ω , 30Ω , 20Ω and 60Ω are connected as shown to a 12 V battery.

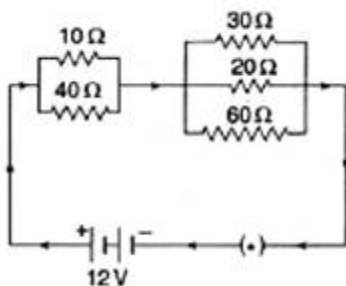

Calculate:

- (a) total resistance in the circuit.
- (b) total current flowing in the circuit.

Answer

(a) when three resistors are connected in parallel, the net resistance can be obtained as followed

$$\frac{1}{R} = \frac{1}{R_1} + \frac{1}{R_2} + \frac{1}{R_3}$$

The resistance of 30ohm , 20ohm and 60ohm are connected in parallel. therefore, the net resistance R will be

$$\frac{1}{R_1} = \frac{1}{30} + \frac{1}{20} + \frac{1}{60} = \frac{6}{60} = 10 \text{ohm} \text{ ----- (1)}$$

The resistance of 10ohm and 60ohm are connected in parallel. Therefore, the net resistance R will be

$$\frac{1}{R} = \frac{1}{R_1} + \frac{1}{R_2}$$

$$\frac{1}{R_2} = \frac{1}{10} + \frac{1}{40} = \frac{5}{40} = 8 \text{ ohm}$$

Now R_1 and R_2 are connected in series

So total resistance in the circuit is $R = 10+8 = 18 \text{ ohm}$

(b) Total current flowing in the circuit

$$I = \frac{V}{R} = \frac{12}{18} = 0.67A$$

24. Question

In the circuit diagram given below, three resistors, R_1 , R_2 and R_3 of 5Ω , 10Ω and 30Ω respectively are connected as shown.

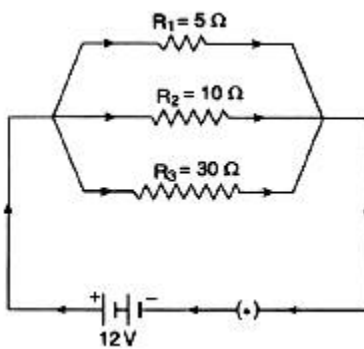

Calculate :

(a) current through each resistor.

(b) total current in the circuit.

(c) total resistance in the circuit.

Answer

(a) Let I_1 , I_2 and I_3 be the current flowing through the resistors of 5 ohm , 10 ohm and 30 ohm , respectively.

According to ohm's law $V=IR$

Here $V= 12 \text{ V}$ and $R = 5 \text{ ohm}$

$$I = V/R$$

$$\text{Current through } R_1 = V/R_1 = 12/5 = 2.4 \text{ A}$$

$$\text{Current through } R_2 = V/R_2 = 12/10 = 1.2 \text{ A}$$

$$\text{Current through } R_3 = V/R_2 = 12/30 = 0.4 \text{ A}$$

(b) Total current in the circuit = Current through R_1 + Current through R_2 + Current through R_3

$$= 2.4 + 1.2 + 0.4 = 4 \text{ A}$$

(c) Total resistance in the circuit = R

$$\frac{1}{R} = \frac{1}{R_1} + \frac{1}{R_2} + \frac{1}{R_3}$$

$$\frac{1}{R} = \frac{1}{5} + \frac{1}{10} + \frac{1}{30}$$

$$R = 3 \text{ ohm}$$

25. Question

A p.d. of 4 V is applied to two resistors of 6 Ω and 2 Ω and 6 Ω connected in parallel. Calculate:

- (a) the combined resistance
- (b) the current flowing in the main circuit
- (c) the current flowing in the 6 Ω resistor.

Answer

(a) When two resistors are connected in series, their resultant resistance is given by

$$R = R_1 + R_2$$

$$\text{Here } R_1 = 6 \text{ ohm}$$

$$R_2 = 2 \text{ ohm}$$

$$\text{Combined resistance, } R = R_1 + R_2 = 6 + 2 = 8 \text{ ohm}$$

(b) We know that the current, $I = V/R$

$$\text{Here } R = 8 \text{ ohm}$$

$$V = 4 \text{ V}$$

$$I = 4/8 = 0.5 \text{ amp}$$

(c) Potential difference across 6ohm resistor $V = I \times R_1 = 0.5 \times 6 = 3 \text{ V}$

26. Question

A p.d. of 6 V is applied to two resistors of 3 Ω and 6 Ω connected in parallel. Calculate:

- (a) the combined resistance
- (b) the current flowing in the main circuit
- (c) the current following in the 3 Ω resistor

Answer

(a) \because the $3\ \Omega$ and $6\ \Omega$ resistance are in parallel, hence the eq. resistance = $\frac{3 \times 6}{3+6} = 2\ \Omega$

(b) $I = V/R_{eq} = 4/2 = 2A$

(c) Current Flowing in $3\ \Omega$ resistor = $\frac{6}{6+3} \times 2 = 1.33\ Amp$

27. Question

In the circuit shown below, the voltmeter reads 10 V.

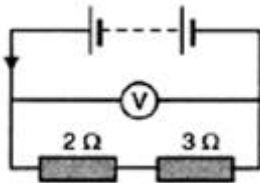

- (a) What is the combined resistance?
- (b) What current flows?
- (c) What is the p.d. across $2\ \Omega$ resistor?
- (d) What is the p.d. across $3\ \Omega$ resistor?

Answer

When two resistors are connected in series, their resultant resistance is given by

$$R = R_1 + R_2$$

Here $R_1 = 2\ \text{ohm}$

$R_2 = 3\ \text{ohm}$

Combined resistance, $R = R_1 + R_2 = 2 + 3 = 5\ \text{ohm}$

(b) We know that the current, $I = V/R$

Here $R = 5\ \text{ohm}$

$V = 10V$

$I = 10/5 = 2\ \text{amp}$

(c) Potential difference across $2\ \text{ohm}$ resistor $V = I \times R_1 = 2 \times 2 = 4V$

(d) Potential difference across $3\ \text{ohm}$ resistor $V = I \times R_2 = 2 \times 3 = 6V$

28. Question

In the circuit given below:

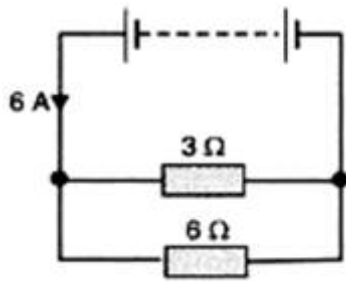

- What is the combined resistance?
- What is the p.d. across the combined resistance?
- What is the p.d. across the 3 Ω resistor?
- What is the current in the 3Ω resistor?
- What is the current in the 6 Ω resistor?

Answer

A

The resistors of 6 ohm and 3 ohm are connected in parallel. Therefore, their combined resistance can be calculated as

$$\frac{1}{R} = \frac{1}{R_1} + \frac{1}{R_2}$$

$$\frac{1}{R} = \frac{1}{6} + \frac{1}{3}$$

R= 2 ohms

(b) The p.d. across the combined resistance, $V= IR$

Here $I = 6A$ and combined resistance = 2 ohms.

So, $V= 6 \times 2 = 12 V$

(c) In parallel connection potential difference remains constant, so Potential difference across 3ohm resistor =12 V

(d) The current in the 3Ω resistor

$$I= V/R_1$$

$$I= 12/3 =4A$$

(e) Current flowing through the 6 ohm resistor = $V/R_2 = 12/6 = 2 A$

29. Question

A 5 V battery is connected to two 20 Ω resistors which are joined together in series.

(a) Draw a circuit diagram to represent this. Add an arrow to indicate the direction of conventional current flow in the circuit.

(b) What is the effective resistance of the two resistors?

(c) Calculate the current that flows from the battery.

(d) What is the p.d. across each resistor?

Answer

A

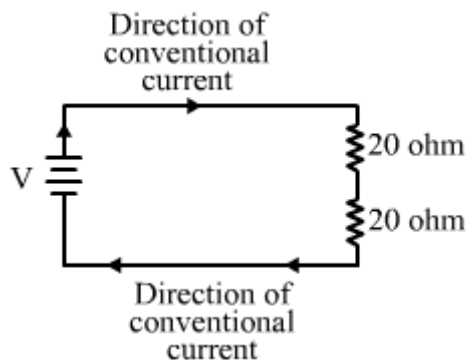

(b) Since two resistors of 20 ohm are connected in series, the effective resistance will be

$$R = R_1 + R_2$$

Here, $R_1 = 20 \text{ ohm}$

$R_2 = 20 \text{ ohm}$

Therefore the effective resistance of the two resistors = $20 + 20 = 40 \text{ ohm}$

(c) Current flowing through the circuit = $I = V/R = 5/40 = 0.125 \text{ amps}$

(d) p.d. across each resistance = $I \times R = 0.125 \times 20 = 2.5 \text{ V}$

30. Question

The figure given below shows an electric circuit in which current flows from a 6V battery through two resistors.

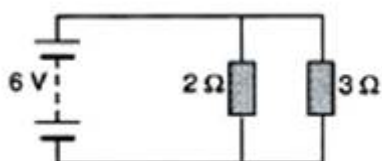

(a) Are the resistors connected in series with each other or in parallel?

(b) For each resistor, state the p.d. across it.

(c) The current flowing from the battery is shared between the two resistors. Which resistor will have bigger share of the current

(d) Calculate the effective resistance of the two resistors.

(e) Calculate the current that flows from the battery.

Answer

(a) In the given figure resistors are connected in parallel.

(b) In a parallel arrangement, the voltage remains the same across each resistor i.e 6V

(c) Due to lower resistance 2 ohm have bigger share of current.

(d) The resistors of 2 ohm and 3 ohm are connected in parallel. Therefore, their combined resistance can be calculated as

$$\frac{1}{R} = \frac{1}{R_1} + \frac{1}{R_2}$$

$$\frac{1}{R} = \frac{1}{2} + \frac{1}{3}$$

$$R = 1.2 \text{ ohm}$$

(e) Current flowing through battery, $I = V/R = 6/1.2 = 5\text{amps}$

31. Question

A 4Ω coil and a 2Ω coil are connected in parallel. What is their combined resistance? A total current of 3A passes through the coils. What current passes through the 2Ω coil?

Answer

The coils of the resistors 4 ohm and 2 ohm are connected in parallel. Therefore

$$\frac{1}{R} = \frac{1}{R_1} + \frac{1}{R_2}$$

$$\frac{1}{R} = \frac{1}{4} + \frac{1}{2}$$

$$R = 4/3 \text{ ohm}$$

Total current = 3 A (given)

Potential difference $V = 3 \times 4/3 = 4V$

Now current through 2Ω coil = $V/2 = 4/2 = 2A$

Long Answer Type Questions-Pg-41

32 A. Question

With the help of a circuit diagram, deduce the equivalent resistance of two resistances connected in series.

Answer

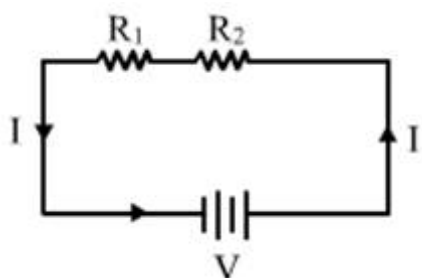

Let the current in the circuit be I amperes and the battery be of strength V volts. Let the combined resistance of the three resistors be R ohms.

Therefore, according to Ohm's law, we have

$$V=IR \text{ ---- (i)}$$

We know that when resistors are connected in series, the current with a battery of V volts.

$$V_1=I \times R_1 \text{ ----- (ii)}$$

$$V_2 =I \times R_2 \text{ ----- (iii)}$$

Let the potential difference across R_1 is V_1 and the potential difference across R_2 is V_2

$$V=V_1+V_2\text{----- (iv)}$$

From equation (i),(ii), (iii) and (iv) we get.

$$IR= I \times R_1+ I \times R_2$$

$$R= R_1+ R_2$$

32 B. Question

Two resistances are connected in series as shown in the diagram:

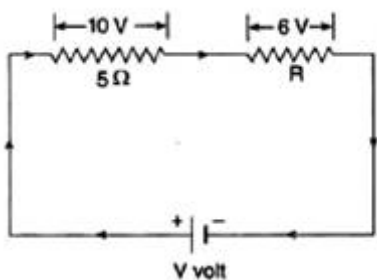

(i) What is the current through the 5 ohm resistance?

(ii) What is the current through R ?

(iii) What is the value of R ?

(iv) What is the value of V ?

Answer

(i) Current through 5 ohm resistor

$$I= V/R$$

$$I = 10/5 = 2A$$

(ii) Two resistances are connected in series. So same current flow through the circuit,

So current flowing through $R =2A$

(iii) As we know that according to ohm's law

$$V=IR$$

So $R = V/I = 6/2 = 3 \text{ ohm}$

(iv) Total V in the given circuit = $V_1 + V_2 = 10 + 6 = 16 \text{ V}$

33 A. Question

With the help of a diagram, derive the formula for the resultant resistance of three resistors connected in series.

Answer

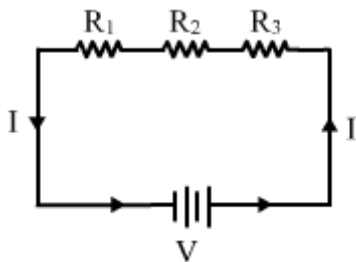

Let the current be I amperes and the battery be of strength V volts. Let the combined resistance of the three resistors be R ohms.

Therefore, according to Ohm's law, we have

$$V = IR \text{ -----(i)}$$

We know that when the resistors are connected in series, the current is the same in all the resistors. Therefore

$$V = V_1 + V_2 + V_3 \text{ ----- (ii)}$$

Let the current flowing through the whole circuit is I , and the equivalent resistance be R .

According to ohm's law

$$V = IR$$

$$V_1 = IR_1 \text{ ----- (iii)}$$

$$V_2 = IR_2 \text{ ----- (iv)}$$

$$V_3 = IR_3 \text{ ----- (v)}$$

By using eq (i),(ii),(iii) ,(iv) and (v) we get

$$IR = IR_1 + IR_2 + IR_3$$

$$R = R_1 + R_2 + R_3$$

33 B. Question

For the circuit shown in the diagram given below

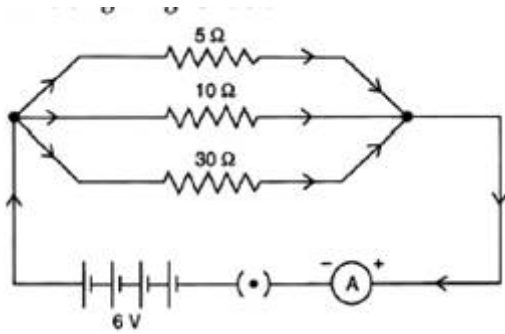

Calculate:

- (i) the value of current through each resistor.
- (ii) the total current in the circuit.
- (iii) the total effective resistance of the circuit.

Answer

(i) Here $R_1 = 5 \text{ ohm}$, $R_2 = 10 \text{ ohm}$ and $R_3 = 30 \text{ ohm}$

The value of current through each resistor is different as they are arranged in parallel connection.

So the current through 5 ohm resistor, $I_1 = V/R = 6/5 = 1.2A$

So the current through 10 ohm resistor, $I_2 = V/R = 6/10 = 0.6A$

So the current through 30 ohm resistor, $I_3 = V/R = 6/30 = 0.2A$

(ii) The total current in the circuit = $I = I_1 + I_2 + I_3$

$$1.2A + 0.6A + 0.2A = 2A$$

(iii) Total resistance in the circuit = R , As the circuit is in parallel connection, so

$$\frac{1}{R} = \frac{1}{R_1} + \frac{1}{R_2} + \frac{1}{R_3}$$

$$\frac{1}{R} = \frac{1}{5} + \frac{1}{10} + \frac{1}{30}$$

$$R = 3 \text{ ohm}$$

34 A. Question

With the help of a circuit diagram, obtain the relation for the equivalent resistance of two resistances connected in parallel.

Answer

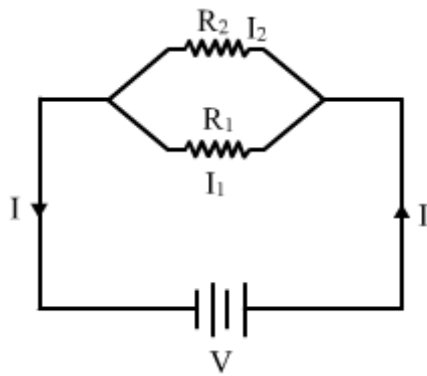

Let the individual resistance of the two resistors be R_1 and R_2 and their combined resistance be R . Let the total current flowing in the circuit be I and strength of the battery be V volts. Then, from Ohm's law, we have: $V = IR \dots (1)$

We know that when resistors are connected in parallel, the potential drop across each resistance is the same. Therefore: $V = I_1 R_1 = I_2 R_2$
 $I = I_1 + I_2 = \frac{V}{R_1} + \frac{V}{R_2}$

$$I = V \left(\frac{1}{R_1} + \frac{1}{R_2} \right) \dots (2)$$

From the equations (1) and (2) we have:

$$\frac{1}{R} = \frac{1}{R_1} + \frac{1}{R_2}$$

34 B. Question

In the circuit diagram shown below, find:

- (i) Total resistance.
- (ii) Current shown by the ammeter A

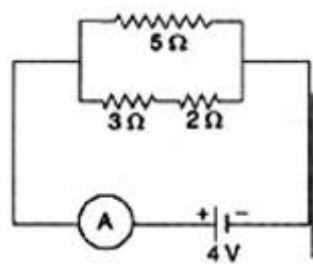

Answer

(i) Let the total resistance of the circuit = R

As the connections are parallel. So the total resistance will be

$$\frac{1}{R} = \frac{1}{R_1} + \frac{1}{R_2}$$

$$R_2 = 3 + 2 = 5 \text{ ohms}$$

$$R_1 = 5 \text{ ohms}$$

$$\frac{1}{R} = \frac{1}{5} + \frac{1}{5}$$

$$\frac{1}{R} = \frac{2}{5}$$

$$R = 2.5 \text{ ohms}$$

(ii) Current shown by the ammeter A will be equal to the current following in the circuit.

$$I = V/R = 4/(2.5)$$

$$= 1.6 \text{ amps}$$

35 A. Question

Explain with the help of a labelled circuit diagram, how you will find the resistance of a combination of three resistors of resistances R_1 , R_2 and R_3 joined in parallel.

Answer

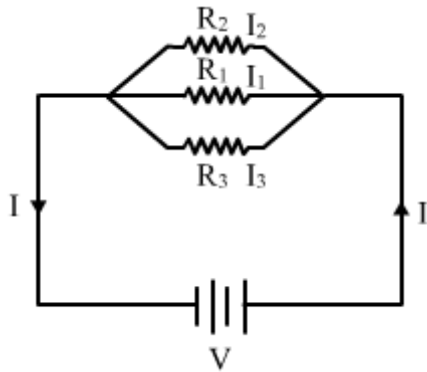

Let the resistance of the three resistors be R_1 , R_2 and R_3 , respectively. Let their combined resistance be R .

Let the total current flowing in the circuit be I and the strength of the battery be V . Then from Ohm's law, we have: $V = IR$ ----- (1)

We know that when the resistors are connected in parallel, the potential drop across each resistance is the same. Therefore:

$$I = I_1 + I_2 + I_3$$

$$I = V/R_1 + V/R_2 + V/R_3$$

$$1/R = 1/R_1 + 1/R_2 + 1/R_3$$

If two resistances are connected in parallel, then the resultant resistance will be

$$1/R = 1/R_1 + 1/R_2 + 1/R_3$$

35 B. Question

In the diagram shown below, the cell and the ammeter both have negligible resistance. The resistors are identical

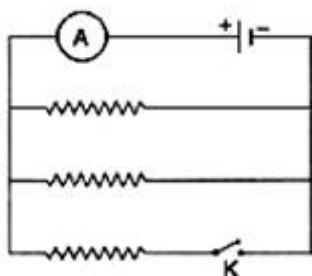

With the switch K open, the ammeter reads 0.6 A. What will the ammeter reading when the switch is closed?

Answer

When switch is open, the upper two resistances are connected in parallel in the circuit.

Effective resistance is $1/R_{eq} = 1/R + 1/R = 2/R$

$$R_{eq} = R/2$$

So the current $= I = V/(R/2) = 0.6A$ (given)

$$V/R = 0.3 A$$

When the switch closes, the third resistance also comes in the circuit.

The effective resistance of the circuit becomes $R/3$

Hence, Current $I = V/(R/3) = 3 (V/R) = 3 \times 0.3 = 0.9 A$

Multiple Choice Questions (MCQs)-Pg-42

36. Question

The figure given below shows three resistors

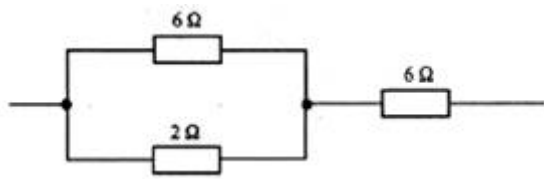

Their combined resistance is:

A. $1\frac{5}{7}\ \Omega$

B. $14\ \Omega$

C. $6\frac{2}{3}\ \Omega$

D. $7\frac{1}{2}\ \Omega$

Answer

Here two resistor 6 ohm and 2 ohm are connected in parallel

$$\frac{1}{R} = \frac{1}{R_1} + \frac{1}{R_2}$$

$$\frac{1}{R} = \frac{1}{6} + \frac{1}{2}$$

$$R = \frac{3}{2}$$

Now R ohm and 6 ohm are in series

$$\text{So the combined resistance } R = \frac{3}{2} + 6 = 7\frac{1}{2}$$

37. Question

If two resistors of 35Ω and 15Ω are joined together in series and then placed in parallel with a 40Ω resistor, the effective resistance of the combination is :

- A. 0.1Ω
- B. 10Ω
- C. 20Ω
- D. 40Ω

Answer

When the resistors are in series, then the combined resistance = $35 \Omega + 15 \Omega = 50 \Omega$

Now 50Ω and 40Ω are connected in parallel, so the combined resistance

$$\frac{1}{R} = \frac{1}{R_1} + \frac{1}{R_2}$$

$$\frac{1}{R} = \frac{1}{50} + \frac{1}{40} = 20 \Omega$$

38. Question

The diagram below shows part of a circuit:

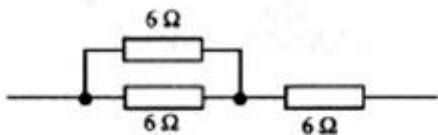

If this arrangement of three resistors was to be placed by a single resistor, its resistance should be :

- A. 9Ω
- B. 4Ω
- C. 6Ω
- D. 18Ω

Answer

the two 6Ω resistors are in parallel. Hence, the Equivalent Resistor = $\frac{6 \times 6}{6 + 6} = 3 \Omega$

Now, 3Ω and 6Ω resistors are in series. Hence the Total Equivalent Resistance = $3 + 6 = 9 \Omega$

39. Question

In the circuit shown below :

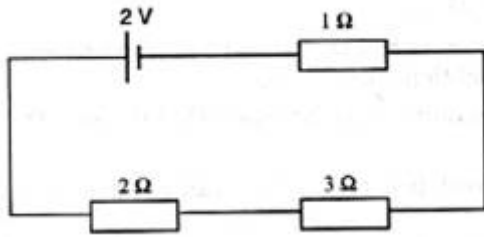

The potential difference across the 3 Ω resistor is:

- A. $\frac{1}{9}$ V
- B. $\frac{1}{2}$ V
- C. 1 V
- D. 2V

Answer

Here all the resistance are connected in series. Therefore net resistance = $2\Omega+3\Omega+1\Omega = 6\Omega$

So current in the circuit = $\frac{2}{6} = \frac{1}{3}$ A

Potential across 3Ω resistor $V = IR$
 $V = \frac{1}{3} \times 3 = 1V$

40. Question

A battery and three lamps are connected as shown:

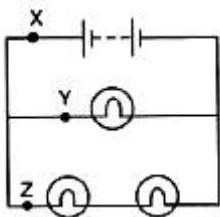

Which of the following statements about the currents at X, Y and Z is correct?

- A. The current at Z is greater than that at Y.
- B. The current at Y is greater than that at Z.
- C. The current at X equal the current at Y.
- D. The current at X equals the current at Z.

Answer

The current at Y is greater than that at Z due to the arrangement of the circuit.

41. Question

V_1 , V_2 and V_3 are the p.d. across the $1\ \Omega$, $2\ \Omega$ and $3\ \Omega$ resistors in the following diagram, and the current is 5A.

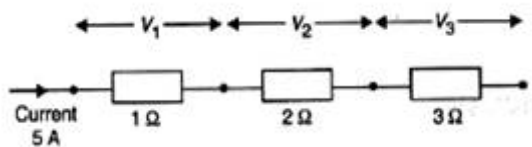

Which one of the columns (a) to (d) shows the correct values of V_1 , V_2 and V_3 measured in volts?

- A. V_1 -1.0, V_2 -2.0, V_3 -3.0
- B. V_1 -5.0, V_2 -10.0, V_3 -15.0
- C. V_1 -5.0, V_2 -2.5, V_3 -1.6
- D. V_1 -4.0, V_2 -3.0, V_3 -2.0

Answer

As $V = IR$

42. Question

A wire of resistance R_1 is cut into five equal pieces. These five pieces of wire are then connected in parallel. If the resultant resistance of this combination be R_2 , then the ratio $\frac{R_1}{R_2}$ is:

- A. $\frac{1}{25}$
- B. $\frac{1}{5}$
- C. 5
- D. 25

Answer

When the wire is cut into 5 pieces, resistance of each part is $R/5$

So, equivalent resistance of the 5 pieces when connected in parallel is

$$\frac{1}{R} = \frac{5}{R} + \frac{5}{R} + \frac{5}{R} + \frac{5}{R} + \frac{5}{R}$$

$$R_1 = R/25$$

So required ratio R: R_1 =25:1

Questions Based on High Order Thinking Skills (HOTS)-Pg-43

43. Question

Show with the help of diagrams, how you would connect three resistors each of resistance $6\ \Omega$ so that the combination has resistance of (i) $9\ \Omega$ (ii) $4\ \Omega$

Answer

(i)

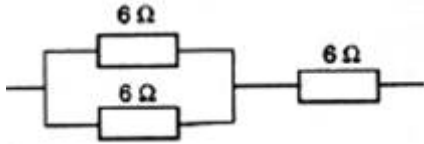

To obtain $9\ \Omega$ resistance two resistances are connected in parallel,

Let the resultant resistance for parallel circuit = R

$$\frac{1}{R} = \frac{1}{6} + \frac{1}{6}$$

$$\frac{1}{R} = \frac{2}{6}$$

$$R = 3$$

Effective resistance = $6 + 3 = 9\ \text{ohms}$

(ii) To obtain $4\ \Omega$ resistance all resistances are connected in parallel

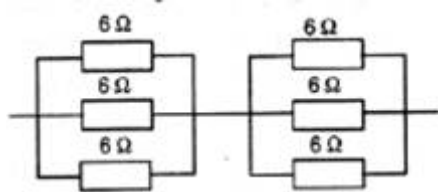

So the effective resistance will be R for each circuit

$$\frac{1}{R} = \frac{1}{6} + \frac{1}{6} + \frac{1}{6}$$

$$\text{Or } R = 2\ \Omega$$

Total resistance = $2\ \Omega + 2\ \Omega = 4\ \Omega$

44. Question

To resistances when connected in parallel give resultant value of $2\ \text{ohm}$; when connected in series the value becomes $9\ \text{ohm}$. Calculate the value of each resistance.

Answer

$$R_1 + R_2 = 9$$

$$R_2 = 9 - R_1$$

$$\frac{1}{R_1} + \frac{1}{R_2} = \frac{1}{2}$$

$$\frac{1}{R_1} + \frac{1}{9 - R_1} = \frac{1}{2}$$

$$\frac{9 - R_1 + R_1}{R_1(9 - R_1)} = \frac{1}{2}$$

$$\frac{9}{9R_1 - R_1^2} = \frac{1}{2}$$

$$R_1^2 - 9R_1 + 18 = 0$$

$$(R_1 - 3)(R_1 - 6) = 0$$

$$R_1 = 3, 6$$

When $R_1 = 3\Omega$, $R_2 = 9 - 3 = 6\Omega$

When $R_1 = 6\Omega$, $R_2 = 9 - 6 = 3\Omega$

45. Question

A resistor of 8 ohm. Calculated in parallel with another resistor X. The resultant resistance of the combination is 4.8 ohms. What is the value of the resistor X?

Answer

Parallel combinations of the resistors will be written as

$$1/x + 1/8 = 1/4.8$$

On solving the above relation,

$$x = 12 \text{ ohms}$$

46. Question

You are given three resistances of 1, 2 and 3 ohms. Show by diagrams, how with the help of these resistances you can get :

- (i) 6Ω (ii) C (iii) 1.5Ω

Answer

- (i) 6 ohm can be obtained by connecting the 1,2 and 3 ohm in series.

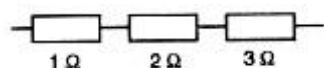

- (ii) $6/11$ ohm can be obtained by connecting the 1,2 and 3 ohm in parallel connection.

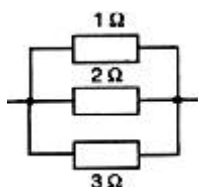

(iii) 1.5 ohm can be obtained by connecting 1 and 2 ohm in series and then by connecting 3 ohm to the resultant resistance i.e 3 ohm in parallel connection

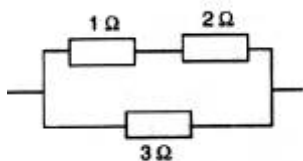

47. Question

How will you connect three resistors of 2Ω, 3Ω and 5Ω respectively so as to obtain a resultant resistance of 2.5 Ω? Draw the diagram to show the arrangement.

Answer

Resistor 2 and 3 ohm are connected in series, 5 ohm resistance is connected parallel to 2 and 3 ohm.

Thus the resultant resistance will be 2.5 ohm

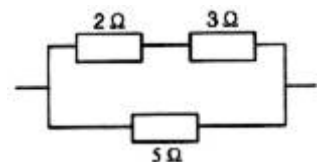

48. Question

How will you connect three resistors of resistance 2Ω, 3 Ω and 6 Ω to obtain a total resistance of: (a) 4Ω, and (b) 1 Ω?

Answer

(a) **For total Resistance to be 4**

we will connect 2 ohm resistance in series with parallel combination of 3 and 6 ohm resistance. When 3 and 6 ohm are in parallel combination then $1/R = 1/3 + 1/6$

or $R = 2$

Now this R connected in series with 2 ohm resistance will give equivalent resistance = $2 + 2 = 4$ ohm.

For total Resistance to be 1 ohm

All the given resistance should be connected in parallel combination $1/R' = 1/2 + 1/3 + 1/6$

Or $R' = 1$ ohm

49. Question

What is (a) highest, and (b) lowest, resistance which can be obtained by combining four resistors having the following resistances?

4Ω, 8Ω, 12Ω, 24Ω

Answer

(a) To obtain the highest resistance we must connect the given resistances in series.

Highest resistance $R = 4 + 8 + 12 + 24 = 48\text{ohms}$

(b) To obtain the lowest resistance we must connect the given resistances in parallel.

$$1/R = 1/4 + 1/8 + 1/12 + 1/24$$

On solving we get, $R = 2\text{ohms}$

50. Question

What is the resistance between A and B in the figure given below?

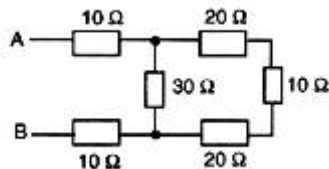

Answer

According to the figure, 20 ohm, 10 ohm and 20 ohm are connected in series so the resultant resistance in the extreme side = $20 + 10 + 20 = 50\text{ ohms}$

Now this 50 ohm is in parallel with 30 ohm, so the resultant resistance become

$$\frac{1}{R} = \frac{1}{50} + \frac{1}{30}$$

On solving we get $R = 18.75\text{ ohm}$

Now 18.75 ohm, 10 ohm and 10 ohm are connected in series. So the resultant resistance become

$$R = 18.75 + 10 + 10 = 38.75\text{ ohm.}$$

51. Question

You are given one hundred 1 Ω resistors. What is the smallest and largest resistance you can make in the circuit using these?

Answer

The greatest possible resistance is the series combination of the resistors.

In series combination of hundred 1 ohm resistors equivalent resistance will be 100 ohm

The least possible resistance is the parallel combination of the resistors.

When resistances are connected in parallel then

$$1/R = 100$$

$$R = 1/100 = 0.01\text{ ohm}$$

52. Question

You are supplied with a number of 100 Ω resistors. How could you combine some of these resistors to make a 250 Ω resistor?

Answer

To make equivalent resistance of 250 ohms one may connect:

1) 2 resistors in series Thus, the resultant would be:

$$100+100= 200 \text{ ohms}$$

2) 2 resistors in parallel Thus, the resultant of 2 parallel combination would be:

$$\frac{100 \times 100}{100+100} = 50 \text{ ohms}$$

3) Now connect the combination of the two (series and parallel) in series: Thus, we may obtain a net resistance of: $200+50 = 250$ ohms

53. Question

The resistors R_1 , R_2 , R_3 and R_4 in the figure given below are all equal in value.

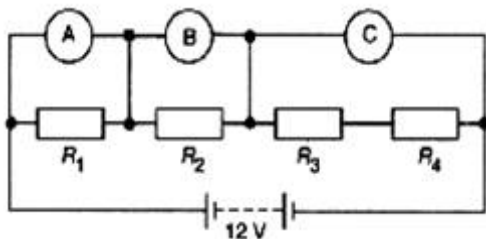

What would you expect the voltmeters A, B and C to read assuming that the connecting wires in the circuit have negligible resistance?

Answer

The four resistors are in series.

Hence, the effective resistance is

$$R_{\text{eff}} = R_1 + R_2 + R_3 + R_4 = R + R + R + R = 4R$$

Hence, the current in the circuit is

$$I = \frac{V}{R} = \frac{12}{4R} = \frac{3}{R}$$

So, the voltage reading across A is

$$V_A = IR_1 = \frac{3}{R} \times R = 3 \text{ V}$$

Similarly, the voltage reading across B is $V_B = 3 \text{ V}$.

The voltage reading across C is

$$V_C = \frac{3}{R} \times (R + R) = \frac{3}{R} \times 2R = 6 \text{ V}$$

54. Question

Four resistances of 16 ohms each are connected in parallel. Four such combinations are connected in series. What is the total resistance?

Answer

When four 16 ohm resistances are connected in parallel combination then the equivalent resistance will be

$$1/R = 1/16 + 1/16 + 1/16 + 1/16 = 4/16$$

$$R = 4 \text{ ohm}$$

When four such combinations are connected in series, then the total resistance = $4+4+4+4 = 16 \text{ ohm}$.

55. Question

If the lamps are both the same in the figure given below and if A_1 reads 0.50 A, what do A_2 , A_3 , A_4 and A_5 read?

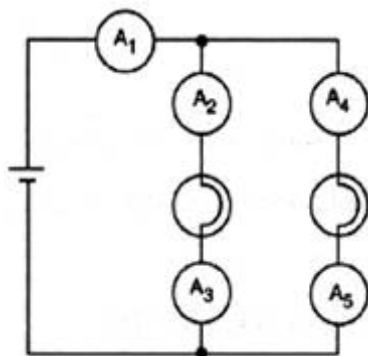

Answer

It is given that the two lamps are identical. So, they will have equal resistance.

The ammeter A_1 reads 0.5 A current. This current will now get distributed equally in the two branches as resistances are equal.

Hence, the ammeters A_2 and A_4 will read 0.25 A each.

Now, A_3 and A_5 are connected in series with A_2 and A_4 , so they will also read 0.25 A.

Very Short Answer Type Questions-Pg-47

1. Question

Are the lights in your house wired in series?

Answer

No, When appliances are connected in a parallel arrangement, each of them can be put on and off independently. This is a feature that is essential in a house's wiring.

2. Question

What happens to the other bulbs in a series circuit if one bulb blows off?

Answer

When bulbs are connected in a series arrangement, if one of them can be put off all bulbs are switched off.

3. Question

What happens to the other bulbs in a parallel circuit if one bulb blows off?

Answer

When bulbs are connected in a parallel arrangement, each of them can be put on and off independently.

4. Question

Which type of circuit, series or parallel, is preferred while connecting a large number of bulbs:

(a) for decorating a hotel building from outside?

(b) for lighting inside the rooms of the hotel?

Answer

(a) For decorating a hotel building from outside we use series connection.

(b) For lighting inside the rooms of the hotel we use parallel connection.

5. Question

Draw a circuit diagram to show two 4 V electric lamps can be lit brightly from two 2 V cells.

Answer

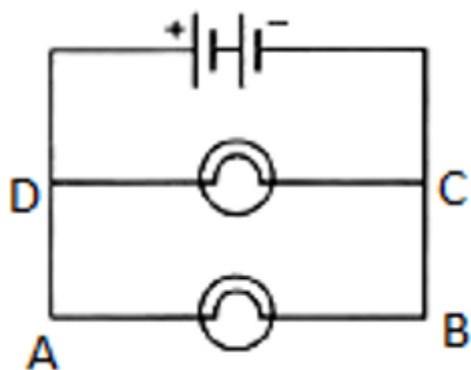

Short Answer Type Questions-Pg-47

6. Question

Why is series arrangement not used for connecting domestic electrical appliances in a circuit?

Answer

In series arrangement if one electrical appliance stops working due to some defect, then all other appliance also stop working as the whole circuit is broken. So we should not use series arrangement for connecting domestic electrical appliances in a circuit.

7. Question

Give three reasons why different electrical appliances in a domestic circuit are connected in parallel.

Answer

Due to the following advantages different electrical appliances in a domestic circuit are connected in parallel:

- (i) Each electrical appliance gets the same voltage as that of the power supply line.
- (ii) When appliances are connected in a parallel arrangement, each of them can be put on and off independently.
- (iii) If one electrical appliance stops working due to some defect, then all other appliances keep working properly.

8. Question

Ten bulbs are connected in a series circuit to a power supply line. Ten identical bulbs are connected in a parallel circuit to an identical power supply line.

- (a) Which circuit would have the highest voltage across each bulb?
- (b) In which circuit would the bulbs be brighter?
- (c) In which circuit, if one bulb blows out, all others will stop glowing?
- (d) Which circuit would have less current in it?

Answer

- (a) Parallel circuit would have the highest voltage across each bulb.
- (b) In Parallel circuit the bulbs will be brighter.
- (c) In series circuit, if one bulb blows out, all others will stop glowing
- (d) Series circuit would have less current in it.

9. Question

Consider the circuits given below:

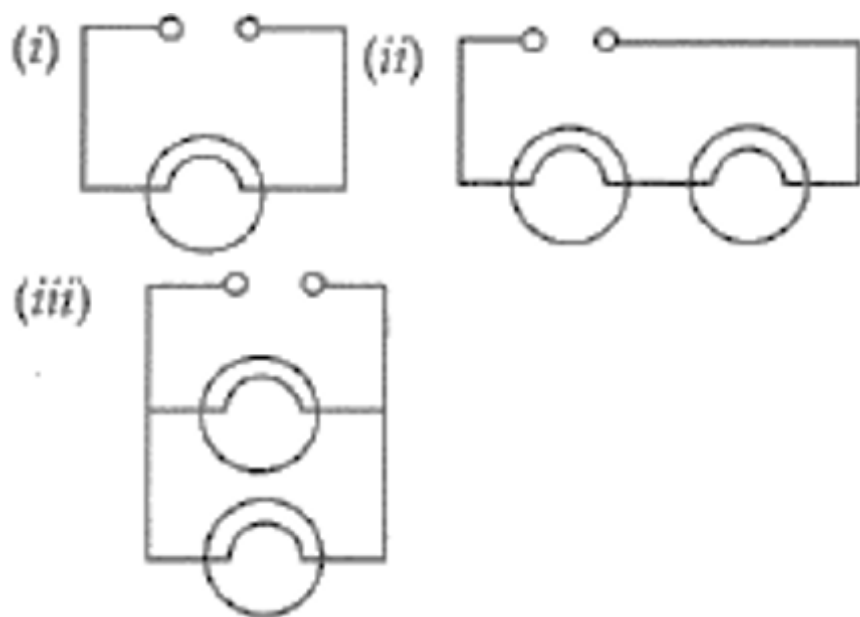

- (a) In which circuit are the lamps dimmest?
- (b) In which circuit or circuits are the lamps of equal brightness to the lamps in circuit (i)?
- (c) Which circuit gives out the maximum light?

Answer

(a) In circuit (ii) the lamps are dimmest as it is connected in series arrangement.

(b) In circuit (iii) the lamps are equal brightness in circuit (i) as both are connected in parallel.

(c) Circuit (ii) give the maximum light.

10. Question

If you were going to connect two light bulbs to one battery, would you use a series or a parallel arrangement? Why? Which arrangement takes more current from the battery?

Answer

If we were going to connect two light bulbs to one battery, we would use a parallel arrangement, so the current will flow through them equally. Series arrangement take more current from battery.

Long Answer Type Questions-Pg-48

11 A. Question

Which is the better way to connect light and other electric appliances in domestic wiring: series circuits or parallel circuits? why?

Answer

When appliances are connected in a parallel arrangement, each of them can be put on and off independently. This is a feature that is essential in a house's wiring.

11 B. Question

Christmas tree lamps are usually wired in series. What happens if one lamp breaks?

Answer

In series circuit, if one bulb blows out, all others will stop glowing.

11 C. Question

An electrician has wired a house in such a way that if a lamp gets fused in one room of the house, all the lamps in other rooms of the house stop working. What is the defect in the wiring?

Answer

The circuit arrangement is in series, so if one bulb blows out, all others will stop glowing.

11 D. Question

Draw a circuit diagram showing two electric lamps connected in parallel together with a cell and a switch that works both lamps. Mark an (A) on your diagram to show where an ammeter should be placed to measure the current.

Answer

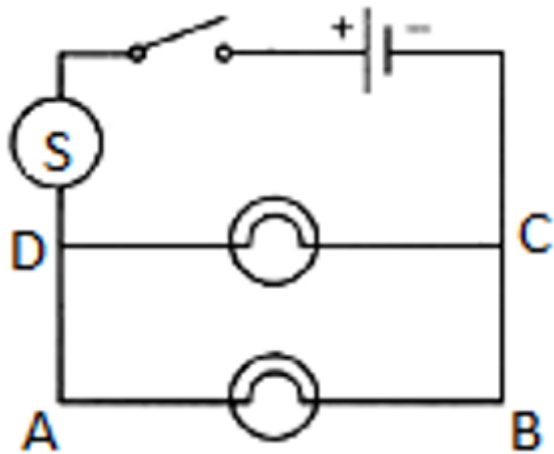

Multiple Choice Questions (MCQs)-Pg-48

12. Question

The lamps in a household circuit are connected in parallel because:

- A. this way they require less current
- B. if one lamp fails the others remain lit
- C. this way they require less power
- D. if one lamp fails the others also fail

Answer

The lamps in a household circuit are connected in parallel because in a parallel arrangement, each of them can be put on and off independently.

13. Question

Using the circuit given below, state which of the following statement is correct?

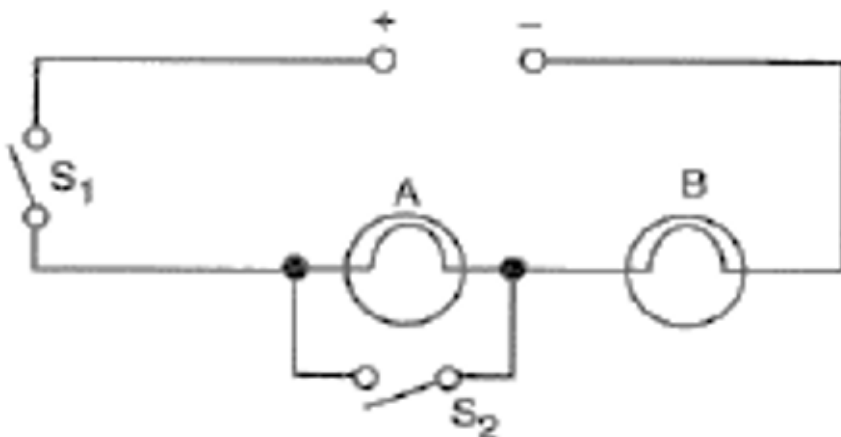

- A. When S_1 and S_2 are closed, lamps A and B are lit.
- B. With S_1 open and S_2 closed, A is lit and B is not lit.
- C. With S_2 open and S_1 closed A and B are lit.
- D. With S_1 closed and S_2 open, lamp A remains lit even if lamp B gets fused.

Answer

When S_2 open and S_1 closed A and B are lit.

Questions Based on High Order Thinking Skills (HOTS)-Pg-48

14 A. Question

Draw a circuit diagram showing two lamps, one cell and a switch connected in series.

Answer

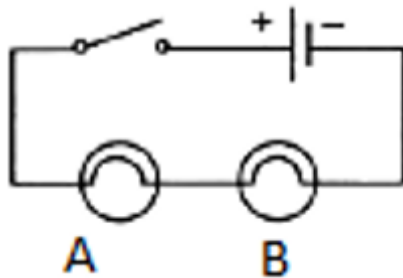

14 B. Question

How can you change the brightness of the lamps?

Answer

When lamps are connected in parallel the brightness of the lamps increases.

15. Question

Consider the circuit given below where A, B and C are three identical light bulbs of constant resistance.

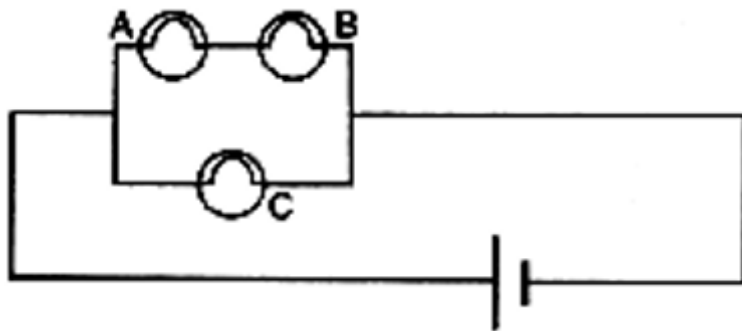

- (a) List the bulbs in order of increasing brightness.
- (b) If C burns out, what will be the brightness of A now compared with before?
- (c) If B burns out instead, what will be the brightness of A and C compared with before?

Answer

- (a) Here A and B are connected in series so the brightness of the A and B will same while C are connected in parallel so the brightness of the bulb C is maximum.
- (b) Their will be no effect on A and B.

(c) A and B are connected in series so if B burns than A also not glow but their will be no effect on C, as C is connected in parallel.

16. Question

How do you think the brightness of two lamps arranged in parallel compares with the brightness of two lamps arranged in series (both arrangements having one cell)?

Answer

The brightness of two lamps which are arranged in parallel is maximum than the the brightness of two lamps arranged in series.

17. Question

If current flows through two lamps arranged:

(a) in series,

(b) in parallel,

and the filament of one lamps breaks, what happens to the other lamp? Explain your answer

Answer

(a) In series circuit, if one bulb blows out, all others will stop glowing.

(b) When lamps are connected in a parallel arrangement, each of them is independently.

18. Question

The figure below shows a variable resistor in a dimmer switch.

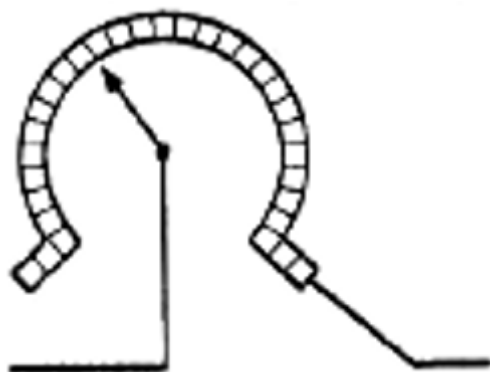

How would you turn the switch to make the lights:

(a) brighter, and

(b) dimmer?

Explain your answer.

Answer

(a) To make the light brighter we turn the switch towards right side.

(b) To make the light dimmer we turn the switch towards left side.

Very Short Answer Type Questions-Pg-58

1. Question

State two factors on which the electrical energy consumed by an electrical appliance depends.

Answer

Two factors on which the electrical energy consumed by an electrical appliance depends on.

- 1). Power rating of the appliance.
- 2). Time for which the appliance is used.

2. Question

Which one has a higher electrical resistance: a 100-watt bulb or a 60 watt bulb?

Answer

As we know that

$$P = \frac{V^2}{R}$$

P is inversely proportional to resistance, so 60 watt has a higher electrical resistance.

3. Question

Name the commercial unit of electric energy.

Answer

The commercial unit of electric energy is Kilowatt-hour.

4. Question

An electric bulb is rated at 220 V, 100 W. What is its resistance?

Answer

Here, $V = 220$ V, $P = 100$ W

$R = ?$

We know that

$$P = \frac{V^2}{R}$$

Thus

$$R = V^2/P = 220^2/100 = 484 \text{ ohm}$$

5. Question

What is the SI unit of (i) electric energy, and (ii) electric power?

Answer

(i) The SI unit of electric energy is joule.

(ii) The SI unit electric power is watt.

6. Question

Name the quantity whose unit is (i) kilowatt, and (ii) kilowatt-hour.

Answer

(i) Kilowatt is the S.I unit of Electric power.

(ii) kilowatt-hour is the S.I unit of Electric energy.

7. Question

Which quantity has the unit of watt?

Answer

Watt is the SI unit of Electric power.

8. Question

What is the meaning of the symbol kWh? Which quantity does it represent?

Answer

kWh is the commercial unit of electrical energy. Its full form is kilowatt-hour.

9. Question

If the potential difference between the end of a wire of fixed resistance is doubled, by how much does the electric power increase?

Answer

As we know that

$$P = \frac{V^2}{R}$$

i.e. as power is directly proportional to the square of potential difference. So, the electric power becomes four times its previous value.

$$P = \frac{(2V)^2}{R}$$

$$P = \frac{4V^2}{R}$$

10. Question

An electric lamp is labeled 12 V, 36 W. This indicates that it should be used with a 12 V supply. What other information does the label provide?

Answer

The electric lamp consumes energy at the rate of 36 J/s.

11. Question

What current will be taken by a 920 W appliance if the supply voltage is 230 V.

Answer

Here $P = 920\text{W}$, $V = 230\text{V}$, $I = ?$

We know that

$$P = V \times I$$

$$920 = 230 \times I$$

$$I = 920/230 = 4\text{amp}$$

Short Answer Type Questions-Pg-58

12. Question

Define watt. Write down an equation linking watts, volts and amperes.

Answer

One watt is defined as the amount of electrical energy consumed by electrical appliances at the rate of 1 joule per second.

$$1 \text{ watt} = 1 \text{ volt} \times 1 \text{ ampere}$$

13. Question

Define watt-hour. How many joules are equal to 1 watt-hour?

Answer

The amount of electrical energy consumed by an electrical appliance of 1 watt power for 1 hour is called watt-hour.

$$1 \text{ watt hour is equal to } 3600 \text{ joules}$$

14. Question

How much energy is consumed when a current of 5 amperes flows through the filament (or element) of a heater having resistance of 100 ohms for two hours? Express it in joules.

Answer

Here, current (I) = 5amp, Resistance(R) = 100 ohms and time = 2h

As we know that

$$\text{Electric energy consumed} = P \times t = I^2Rt$$

$$= 5^2 \times 100 \times 2$$

$$= 5000 \text{ Wh}$$

$$= 5 \text{ kwh}$$

We know that

$$1\text{kwh} = 3.6 \times 10^6 \text{ J}$$

$$\text{Therefore, } 5\text{kwh} = 5 \times 3.6 \times 10^6 \text{ J} = 18 \times 10^6 \text{ J}$$

15. Question

An electric bulb is connected to a 220 V power supply line. If the bulb draws a current of 0.5 A, calculate the power of the bulb.

Answer

Here, Potential difference (V) = 220V, Current (I) = 0.5amp, Power = ?

We know that

$$P = VI = 220 \times 0.5$$

$$P = 110 \text{ watt}$$

16. Question

In which of the following cases ore electrical energy is consumed per hour?

(i) A current of 1 ampere passed through a resistance of 300 ohms.

(ii) A current of 2 amperes passed through a resistance of 100 ohms.

Answer

(i) Here current (I) = 1 A, Resistance (R) = 300 ohm, time(t) = 1h

We know that

$$P = I^2R = 1^2 \times 300 = 300 \text{ W}$$

$$E = P \times t = 300 \times 1 = 300 \text{ Wh}$$

(ii) Here Current (I) = 2 A Resistance(R) = 100 ohm, time (t) = 1h

We know that

$$P = I^2R = 2^2 \times 100 = 400 \text{ W}$$

$$E = P \times t = 400 \times 1 = 400 \text{ Wh}$$

Hence, in case (ii), the electrical energy consumed per hour is more.

17. Question

An electric kettle rated at 220 V, 2.2 kW, works for 3 hours. Find the energy consumed and the current drawn.

Answer

Here potential difference(V) = 220V, Power (P) = 2.2kW = 2200W, time(t) = 3h

We know that

Electrical energy consumed = $P \times t = 2.2 \times 3 = 6.6 \text{ kWh}$

We have, $P = V \times I$

$$I = P/V$$

$$I = 2200/220$$

$$= 10\text{amp}$$

18. Question

In a house two 60 W electric bulbs are lighted for 4 hours, and three 100 W bulbs for 5 hours every day. Calculate the electric energy consumed in 30 days.

Answer

When two electric bulb of 60W are lighted for 4 hours then

Here, $p_1 = 60\text{w}$

Number, $n_1 = 2$

Time for daily use, $t_1 = 4\text{h}$

Total electrical consumed everyday, $E_1 = n_1 \times p_1 \times t_1$

$$= 2 \times 60 \times 4 = 480$$

Energy consumed in 30 days = $30 \times 0.48 = 14.4\text{Kwh}$ (As $1\text{kW} = 1000\text{W}$)

When three electric bulb of 100W are lighted for 5 hours then

Here, $p_2 = 100\text{w}$

Number, $n_2 = 3$

Time for daily use, $t_2 = 5\text{h}$

Total electrical consumed every day, $E_1 = n_2 \times p_2 \times t_2$

$$= 3 \times 100 \times 5 = 1500$$

Energy consumed in 30 days = $30 \times 1.5 = 45\text{Kwh}$ (As $1\text{kW} = 1000 \text{ W}$)

Total electrical consumed in 30 days = $14.4\text{Kwh} + 45\text{Kwh} = 59.4 \text{ kWh}$

19. Question

A bulb is rated as 250 V; 0.4 A Find its:

(i) power, and (ii) resistance.

Answer

(i) We know that

$$V = 250V, I = 0.4\text{amp}$$

$$\text{Power} = VI = 250 \times 0.4 = 100\text{watt}$$

(ii) We have,

$$V = 250V, I = 0.4\text{amp}$$

We know that

$$P = I^2R$$

$$100 = 0.4^2 \times R$$

$$R = 625\text{ohm}$$

20. Question

For a heater rated at 4 kW and 220 V, calculate:

- (a) the current,
- (b) the resistance of the heater,
- (c) the energy consumed in 2 hours, and
- (d) the cost if 1 kWh is priced at ₹ 4.60

Answer

(a) Here, $P = 4\text{kw}$, $V = 220\text{v}$

$$I = ?$$

We know that

$$\text{Power} = VI = 220 \times I$$

$$4000 = 220I$$

$$I = 4000/220 = \mathbf{18.18A}$$

(b) Here, $P = 4\text{kw}$, $V = 220\text{v}$

$$R = ?$$

We know that,

$$P = I^2R$$

$$P = (18.18)^2 \times R$$

$$R = 4000/(18.18)^2$$

$$R = \mathbf{12.10 \Omega}$$

(c) Here, $P = 4\text{kw}$, time = 2hr

$$\text{Energy consumed in two hour} = P \times t$$

$$= 4 \times 2$$

= **8kw-hr**

(d) If 1kwh = Rs 4.6

Here, Energy consumed in two hour = 8kwh

So, total cost = $8 \times 4.6 =$ **Rs 36.8**

21. Question

An electric motor take 5 amperes current from a 220 volts supply line. Calculate the power of the motor and electrical energy consumed by it in 2 hours.

Answer

Here current (I) = 5amp, Potential difference(V) = 220 volt, time = 2h,

We have to find

Power (P) = ?

Energy (E) = ?

We know that

$$P = V \times I$$

$$= 220 \times 5$$

$$= 1100 \text{ watt}$$

$$= 1.1 \text{ kW}$$

Energy consumed, $E = P \times t$

$$= 1.1 \times 2$$

$$= 2.2 \text{ kWh}$$

22. Question

Which users more energy: a 250 W TV set in 1 hour or a 1200 W toaster in 10 minutes?

Answer

TV set uses 0.25 kWh energy whereas toaster uses 1.20 kWh energy. So, toaster uses more energy.

23. Question

Calculate the power used in the 2 Ω resistor in each of the following circuits:

(i) a 6V battery in series with 1 Ω and 2 Ω resistors.

(ii) a 4 V battery in parallel with 12 Ω and 2 Ω resistors.

Answer

(a) Here V = 6 volt, $R_1 = 1$ ohm, $R_2 = 2$ ohm

The connection is in series. So Equivalent resistance = $R_1 + R_2 = 1 + 2 = 3$ ohm

We know that

$$\text{Total current } I = V/R = 6/3 = 2A$$

$$\text{Current through } R_2 = I_2 = I = 2A$$

$$\text{Voltage across } R_2 = V_2 = I_2 R_2 = 2 \times 2 = 4 \text{ ohm}$$

$$\text{Power used in } R_2 = I_2 V_2 = 2 \times 4 = 8W$$

(b) Here, $V = 4 \text{ volt}$, $R_1 = 12 \text{ ohm}$, $R_2 = 2 \text{ ohm}$

We know that, as the connection is in parallel so voltage across $R_2 = V_2 = V = 4V$

$$\text{Current across } R_2 = I_2 = V_2/R_2 = 4/2 = 2A$$

As power = IV

$$\text{Power used in } R_2 = I_2 V_2 = 2 \times 4 = 8W$$

24. Question

Two lamps, one rated 40 W at 220 V and the other 60 W and 220 V, are connected in parallel to the electric supply at 220 V.

(a) Draw a circuit diagram to show the connections.(b) Calculate the current drawn from the electric supply.

(b) Calculate the total energy consumed by the two lamps together when they operate for one hour.

Answer

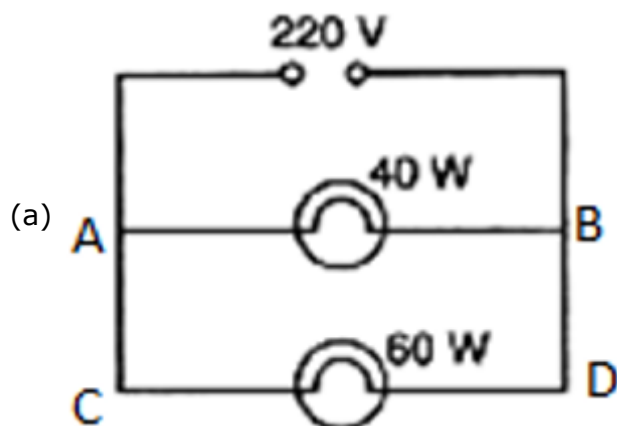

(b) As the connection is in parallel.

So voltage across both the bulbs is same and is equal to 220V.

Using the Formula $P=VI$,

We can get I as $I=P/V$

Where:- P = Power I =Current V =Voltage/Potential Difference

$$\text{Current through AB i.e. 40W lamp} = I_1 = P_1/V = 40/220 \text{ A}$$

$$\text{Current through CD i.e. 60W lamp} = I_2 = P_2/V = 60/220 \text{ A}$$

Total current drawn from the electric supply = $40/220 + 60/220 = 0.45 \text{ A}$

(c) We know that Energy = Power x Time

Total Power to two bulbs together = $40\text{W} + 60\text{W} = 100\text{W}$

According to the question both of the bulbs are being operated together at 1 hour

\therefore Energy = $100\text{W} \times 1\text{hr}$ Energy = 100Whr

We know $1\text{Whr} = 3600 \text{ Joules}$

$\therefore 100\text{Whr} = 3600 \times 100 = 360000 \text{ Joules} = 360 \text{kJoules}$

25. Question

An electric kettle connected to the 230 V mains supply draws a current of 10 A. Calculate:

(a) the power of the kettle.

(b) the energy transferred in 1 minute.

Answer

(a) Here, $V = 230\text{V}$, $I = 10\text{amp}$

We know that, $P = VI$

$P = 230 \times 10$

$P = 2300 \text{ watt} = 2300 \text{ J/s}$

(b) The energy transferred in 1 minute. = $P \times t = 2300 \text{ J/s} \times 60\text{s} = 138000 \text{ J}$

26. Question

A 2 kW heater, a 200 W TV and three 100 W lamps are all switched on from 6 p.m. to 10 p.m. What is the total cost at Rs. 5.50 per kWh?

Answer

Here for heater we have, $P = 2\text{kW}$, $t = 4\text{h}$

So energy consumed by heater, $E = P \times t = 2 \times 4 = 8\text{kWh}$

Here for TV, we have, $P = 200\text{W} = 0.2\text{kW}$, time $10\text{pm} - 6\text{pm} = 4\text{h}$

So energy consumed by TV, $E = P \times t = 0.2 \times 4 = 0.8\text{kWh}$

Here for TV, we have, $P = 100\text{W} = 0.1\text{kW}$, $t = 4\text{h}$, number of lamp(n) = 3

So energy consumed by three lamps, $E = n \times P \times t = 3 \times 0.1 \times 4 = 1.2\text{kWh}$

Total energy consumed by heater, TV and three lamps = $8 + 0.8 + 1.2 = 10\text{kWh}$

Cost of $1\text{kWh} = \text{Rs. } 5.50$

Cost of $10\text{kWh} = \text{Rs. } 5.50 \times 10 = \text{Rs. } 55$

27. Question

What is the maximum power in kilowatts of the appliance that can be connected safely to a 13 A; 230 V mains socket?

Answer

Here $I = 13\text{amp}$, $V = 230\text{V}$

As we know that

$$\text{Power} = VI$$

$$= 230 \times 13$$

$$= 2990\text{W}$$

$$P = 2.99\text{kW}$$

28. Question

An electric fan runs from the 230 V mains. The current flowing through it is 0.4 A. At what rate is electrical energy transferred by the fan?

Answer

Here, $V = 230\text{V}$, $I = 0.4\text{amp}$

We know that power is the rate at which electric energy is transferred

$$P = V \times I$$

$$= 230 \times 0.4$$

$$= 92 \text{ W} = 92 \text{ J/s}$$

Long Answer Type Questions-Pg-59

29 A. Question

What is meant by "electric power"? Write the formula for electric power in terms of potential difference and current.

Answer

The rate at which electrical energy is consumed, or the rate of doing electric work is known as electric power.

We know that

$$P = VI$$

29 B. Question

The diagram below shows a circuit containing a lamp L, a voltmeter and an ammeter. The voltmeter reading is 3 V and the ammeter reading is 0.5 A.

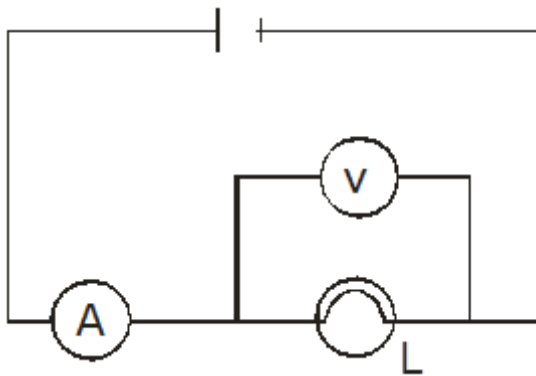

(i) What is the resistance of the lamp?

(ii) What is the power of the lamp?

Answer

(i) resistance = $V/I = 3/0.5 = 6 \Omega$

(ii) $P = VI = 3 \times 0.5 = 1.5 \text{ Watt}$

29 C. Question

Define kilowatt-hour. How many joules are there in one kilowatt-hour?

Answer

The amount of electrical energy consumed when an electrical appliance having a power rating of 1 kilowatt is used for 1 hour is called One kilowatt hour.

$$1\text{kWh} = 3.6 \times 10^6\text{J}$$

29 D. Question

Calculate the cost of operating a heater of 500 W for 20 hours at the rate of ₹ 3.90 per unit.

Answer

Here, Power of heater (P) = 500W = 0.5kW, Time(t) = 20hr

We know that

$$\text{Energy consumed} = P \times t = 0.5 \times 20$$

$$= 10\text{kwh}$$

$$\text{Total cost} = 10 \times \text{cost per unit}$$

$$\text{Cost per unit} = \text{Rs. } 3.9 \text{ per unit}$$

$$\text{Therefore, total cost} = 10 \times 3.9 = \text{Rs } 39$$

Multiple Choice Questions (MCQs)-Pg-59

30. Question

When an electric lamp is connected to 12 V battery, it draws a current of 0.5 A. The power of the lamp is :

- A. 0.5 W
- B. 6W
- C. 12 W
- D. 24W

Answer

We know that

$$P = VI$$

$$P = 12 \times 0.5 = 6W$$

31. Question

The unit for expressing electric power is:

- A. volt
- B. joule
- C. coulomb
- D. watt

Answer

The unit for expressing electric power is watt

32. Question

Which of the following is likely to be the correct wattage for an electric iron used in our homes?

- A. 60 W
- B. 250 W
- C. 850 W
- D. 2000 W

Answer

The correct wattage for an electric iron used in our homes is 850 W.

33. Question

An electric heater is rated at 2kW. Electrical energy costs ₹ 4 per kWh. What is the cost of using the heater for 3 hours?

- A. ₹ 12
- B. ₹ 24
- C. ₹ 36
- D. ₹ 48

Answer

Energy consumed = $P \times t = 2 \times 3 = 6\text{kWh}$

Total cost = $6 \times \text{cost per unit}$

Cost per unit = Rs. 4 per kWh

Therefore, total cost = $6 \times 4 = \text{Rs } 24$

34. Question

The SI unit of energy is:

- A. joule
- B. coulomb
- C. watt
- D. ohm-metre

Answer

The SI unit of energy is joule.

35. Question

The commercial unit of energy is:

- A. watt
- B. watt-hour
- C. kilowatt-hour
- D. kilo-joule

Answer

The commercial unit of energy is kilowatt-hour.

36. Question

How much energy does a 100 W electric bulb transfer in 1 minute?

- A. 100 J
- B. 600 J
- C. 3600 J
- D. 6000 J

Answer

Energy consumed = $P \times t = 100 \times 60 = 6000 \text{ joule}$

As in 1 minute = 60 second.

37. Question

An electric kettle for use on a 230 V supply is rated at 3000 W. For safe working, the cable connected to it should be able to carry at least:

- A. 2 A
- B. 5 A
- C. 10 A
- D. 15 A

Answer

$$\text{As } P = VI$$

$$I = P/V$$

38. Question

How many joules of electrical energy are transferred per second by a 6V; 0.5 A lamp?

- A. 30 J/s
- B. 12 J/s
- C. 0.83 J/s
- D. 3 J/s

Answer

$$\text{As } P = VI$$

39. Question

At a given time, a house is supplied with 100 A at 220 V. How many 75 W, 220 V light bulbs could be switched on in the house at the same time (if they are all connected in parallel)?

- A. 93
- B. 193
- C. 293
- D. 393

Answer

When they are connected in parallel 293 bulb will glow in the house at the same time.

40. Question

If the potential difference between the ends of a fixed resistor is halved, the electric power will become:

- A. double
- B. half
- C. four times

D. one-fourth

Answer

If the potential difference between the ends of a fixed resistor is halved, the electric power will become one-fourth.

Questions Based on High Order Thinking Skills (HOTS)-Pg-60

41. Question

State whether an electric heater will consumer more electrical energy or less electrical energy per second when the length of its heating element is reduced. Given reasons for our answer.

Answer

An electric heater will consume more electrical energy as power is inversely proportional to the resistance.

42. Question

The table below shows the current in three different electrical appliances when connected to the 240 V mains supply:

Appliance	Current
Kettle	8.5 A
Lamp	0.4 A
Toaster	4.8 A

(a) Which appliance has the greatest electrical resistance? How does the data show this?

(b) The lamp is connected to the mains supply by using a thin, twin-cored cable consisting of live and neutral wires. State two reasons why this cable should not be used for connecting the kettle to the mains supply.

(c) Calculate the power rating of the kettle when it is operated from the 240 V mains supply.

(d) A man takes the kettle abroad where the mains supply is 120 V. What is the current in the kettle when it is operated from the 120 V supply?

Answer

(a) Lamp has the greatest electrical resistance as resistance oppose the flow of current, and the lamp has least amount of current.

(b) According to the given data large amount of current is needed by kettle, so it must be connected to the earthing.

(c) As we know that

$$P = VI$$

$$V = 240V, I = 8.5A$$

$$P = 240 \times 8.5 = 2040 \text{ W} = 2.04 \text{ kW}$$

(d) When kettle is connected to 240 V supply, then the $P = 2040 \text{ W}$

$$R = V^2/P = \frac{240 \times 240}{2040}$$

$$R = 28.23 \text{ ohm}$$

Now, when $V = 120V$, $R = 28.23 \text{ ohm}$

$$I = V/R = 120/28.23 = 4.25A$$

43. Question

A boy noted the readings on his home's electricity meter on Sunday at 8 AM and again on Monday at 8 AM (see Figures below).

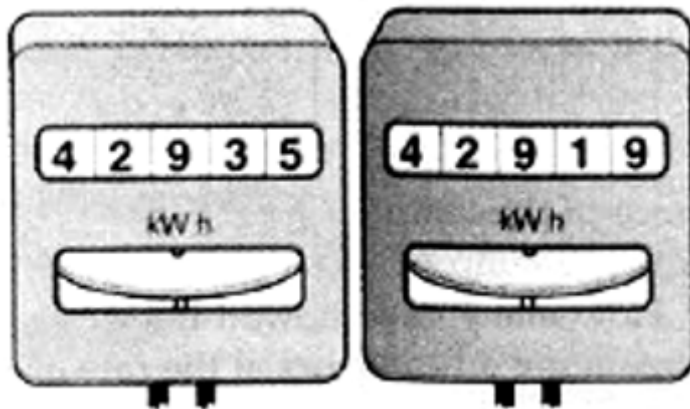

(a) What was the meter reading on Sunday ?

(b) What was the meter reading on Monday?

(c) How many units of electricity have been used ?

(d) If the rate is Rs. 5 per unit, what is the cost of electricity used during this time?

Answer

(a) The meter reading on Sunday is 42919.

(b) The meter reading on Monday is 42935.

(c) Units of electricity used = 42935 - 42919 = 16 units.

(d) The cost of 1 unit is Rs 5. So the cost of 16 units = $16 \times 5 = 80$ rupees

44. Question

An electric bulb is rated as 10 W, 220V. How many of these bulbs can be connected in parallel across the two wires of 220 V supply line if the maximum current which can be drawn is 5A ?

Answer

Here it is given $P = 10\text{W}$, $V = 220\text{V}$, $I = 5\text{A}$

As we know that

$$P = VI$$

$$= 220 \times 5$$

$$P = 1100\text{W}$$

Power of one bulb = 10W

So the total no. of bulbs that can be connected = $1100/10 = 110$

45. Question

Two exactly similar electric lamps are arranged (i) in parallel, and (ii) in series. If the parallel and series combination of lamps are connected to 220 V supply line one by one, what will be the ratio of electric power consumed by them?

Answer

As we know that

$$\text{Electric power consumed} = V^2/R$$

Here V is given we have to find the value of R

So when the connection is in parallel

The equivalent resistance is

$$\frac{1}{R} = \frac{1}{R} + \frac{1}{R} = \frac{2}{R}$$

$$\text{so } R_{\text{equ}} = \frac{R}{2}$$

Electric power consumed in parallel connection

$$= \frac{220 \times 220}{\frac{R}{2}} = \frac{96800}{R}$$

When the connection is in Series

The equivalent resistance = $R+R = 2R$

Electric power consumed in series connection

$$= \frac{220 \times 220}{R} = \frac{24200}{R}$$

The ratio of electric power consumed by them

$$= \frac{P_{parallel}}{P_{series}} = \frac{\frac{96800}{R}}{\frac{24200}{R}}$$
$$= \frac{4}{1}$$

Very Short Answer Type Questions-Pg-66

1. Question

How does the heat H produced by a current passing through a fixed resistance wire depend on the magnitude of current I ?

Answer

Heat produced, $H = I^2Rt$

As heat produced is directly proportional to the square of current.

2. Question

If the current passing through a conductor is doubled, what will be the change in heat produced?

Answer

Heat produced, $H = I^2Rt$

So, If the current passing through a conductor is doubled then heat produced becomes four times.

3. Question

Name two effects produced by electric current.

Answer

The two effects produced by electric current are:

- (a) Heating effect of current
- (b) Magnetic effect of current

4. Question

Which effect of current is utilized in an electric light bulb?

Answer

Heating effect of current is utilized in an electric light bulb.

5. Question

Which effect of current is utilized in the working of an electric fuse?

Answer

Heating effect of current is utilized in the working of an electric fuse.

6. Question

Name two devices which work on the heating effect of electric current.

Answer

The two devices which work on the heating effect of electric current are Electric heater and electric fuse.

7. Question

Name two gases which are filled in filament type electric light bulbs.

Answer

Argon and nitrogen are filled in filament type electric light bulbs,

8. Question

Explain why, filament type electric bulbs are not power efficient.

Answer

Due to the heating effect of current lots of electric power is consumed by the filament of a bulb

9. Question

Why does the connecting cord of an electric heater not glow hot while the heating element does ?

Answer

Due to the low resistance of copper the connecting cord of the heater does not glow because negligible heat is produced in it by passing current but the heating element made of nichrome glows because it becomes red-hot due to the large amount of heat produced on passing current (because of its high resistance).

Short Answer Type Questions-Pg-66

10 A. Question

Write down the formula for the heat produced when a current I is passed through a resistor R for time t .

Answer

The heat produced when a current I is passed through a resistor R for time t will be

$$\text{Heat produced, } H = I^2Rt$$

10 B. Question

An electric iron of resistance 20 ohms draws a current of 5 amperes. Calculate the heat produced in 30 seconds.

Answer

Here,

$$R = 20\text{ohm, } I = 5\text{amp, } t = 30\text{s}$$

$$\text{We know that } H = I^2Rt$$

$$H = 5^2 \times 20 \times 30$$

$$H = 15000 \text{ J}$$

11. Question

State three factors on which the heat produced by an electric current depends. How does it depend on these factors?

Answer

Heat produced by an electric current is given as $H = I^2Rt$, that means

(i) Heat produced is directly proportional to square of current.

(ii) Heat produced is directly proportional to resistance.

(iii) Heat produced is directly proportional to the time for which current flows.

12 A. Question

State and explain Joule's law of heating.

Answer

Joule's law of heating states that when a current of I amperes flows in a wire of resistance R ohms for time t seconds then the heat produced in joules and is given by $H = I^2Rt$

The law implies that heat produced in a resistor is (i) directly proportional to the square of current for a given resistance, (ii) directly proportional to resistance for a given current and (iii) directly proportional to the time for which current flows through the resistors.

12 B. Question

A resistance of 40 ohms and one of 60 ohms are arranged in series across 220 volt supply. Find the heat in joules produced by this combination of resistances in half a minute.

Answer

Here it is given that $R_1 = 40$ ohms, $R_2 = 60$ ohms, $V = 220V$, $t = 30$ sec

Here R_1 and R_2 are arranged in series connection.

So the equivalent resistance = $R = 40+60 = 100$ ohms

According to Ohm's law, we know that

$$V = IR$$

$$I = V/R$$

$$I = 220/100 = 2.2\text{amp}$$

As we know that heat produced in joules is given by $H = I^2Rt$

Substituting the values of I , R and t in eq. $H = I^2Rt$

$$H = (2.2)^2 \times 100 \times 30$$

$$H = 14520 \text{ J}$$

13. Question

Why is an electric light bulb not filled with air? Explain why argon or nitrogen is filled in an electric bulb.

Answer

As the filament of the bulb is made from tungsten, so when we fill air inside the electric bulb this tungsten filament will burn quickly. So we fill unreactive gas like argon or nitrogen in the electric bulb to prolong the life of filament.

14. Question

Explain why, tungsten is used for making the filaments of electric bulbs.

Answer

Due to its very high melting point of tungsten it is used for making the filaments of electric bulbs

15. Question

Explain why, the current that makes the heater element very hot, only slightly warms the connecting wires leading to the heater.

Answer

Due to the low resistance of the connecting wires of the heater negligible heat is produced in them by passing current so it is slightly warm.

16. Question

When a current of 4.0 A passes through a certain resistor for 10 minutes, 2.88×10^4 J of heat are produced. Calculate:

(a) the power of the resistor.

(b) the voltage across the resistor.

Answer

(a), Here it is given,

$$I = 4 \text{ amp,}$$

$$t = 10 \text{ min} = 10 \times 60 = 600 \text{sec, } H = 2.88 \times 10^4 \text{J}$$

We know that according to Joule's law of heating

$$H = I^2RT$$

$$28800 = 4^2 \times R \times 600$$

$$R = 3 \text{ohms}$$

We know that

$$P = I^2 \times R$$

$$= 4^2 \times 3$$

$$P = 48 \text{W}$$

(b) Here we have to find the potential difference, $V = ?$

We know that

$$V = IR$$

$$V = 4 \times 3$$

$$V = 12 \text{V}$$

17. Question

A heating coil has a resistance of 200Ω . At what rate will heat be produced in it when a current of 2.5 A flows through it ?

Answer

Here Resistance of the coil(R) = 200 ohms , Current (I) = 2.5 amp , time(t) = 1 sec

We know that according to Joule's law of heating

$$H = I^2RT$$

$$H = (2.5)^2 \times 200 \times 1$$

$$H = 1250 \text{ J/s}$$

18. Question

An electric heater of resistance 8Ω takes a current of 15 A from the mains supply line. Calculate the rate at which heat is developed in the heater.

Answer

Here Resistance (R) = 8 ohms , Current(I) = 15 amp , time (t) = 1 sec

We know that according to Joule's law of heating

$$H = I^2RT$$

$$H = 15^2 \times 8 \times 1$$

$$H = 1800 \text{ J/s}$$

19. Question

A resistance of 25Ω is connected to a 12 V battery. Calculate the heat energy in joules generated per minute.

Answer

Here $R = 25 \text{ ohms}$, $V = 12 \text{ V}$, $H = ?$, $t = 60 \text{ sec}$

According to Ohm's law

$$V = IR$$

$$12 = 25I$$

$$I = 0.48 \text{ amp}$$

We know that according to Joule's law of heating

$$H = I^2RT$$

$$H = 0.48^2 \times 25 \times 60$$

$$H = 345.6 \text{ J}$$

20. Question

100 joules of heat is produced per second in a 4 ohm resistor. What is the potential difference across the resistor?

Answer

Here, it is given $H = 100 \text{ J}$, $t = 1 \text{ sec}$, $R = 4 \text{ ohms}$,

We know that according to Joule's law of heating

$$H = I^2RT$$

$$100 = I^2 \times 4 \times 1$$

$$100/4 = I^2$$

$$I = 5 \text{ amp}$$

Again we know that

$$V = IR$$

$$V = 5 \times 4$$

$$= 20 \text{ V}$$

21 A. Question

Derive the expression for the heat produced due to a current 'I' flowing for a time interval 't' through a resistor 'R' having a potential difference 'V' across its ends. With which name is this relation known?

Answer

All materials offer resistance to the flow of current through them. So some external energy is required to make the current flow. This energy is provided by the battery. Some of this energy gets dissipated as heat energy, so the resistor becomes hot.

Work done in carrying a charge Q through a potential difference V is given as

$$\text{Also, } Q = I t$$

Using Ohm's law, $V = I R$

$$W = I^2 R t$$

This work done in carrying the charge through the wire appears as the heat produced.

$$\text{i.e. } H = V I t = I^2 R t.$$

this energy is dissipated as heat energy.

This law is called Joule law of heating effect.

21 B. Question

How much heat will an instrument of 12 W produce in one minute if it is connected to a battery of 12 V?

Answer

Here, it is given that $P = 12\text{W}$, $V = 12\text{V}$, $t = 60\text{sec}$

We know that

$$P = VI$$

$$I = P/V = 12/12 = 1\text{A}$$

Again, we know that

$$V = IR$$

$$R = V/I = 12/1 = 12\text{ohm}$$

So according to the Joule's heating law, we know that

$$H = I^2 R t$$

$$H = 1^2 \times 12 \times 60$$

$$H = 720\text{J}$$

21 C. Question

The current passing through a room heater has been halved. What will happen to the heat produced by it?

Answer

Joule heating is given by

$$H = i^2Rt$$

H is the heat produced, i is the current through the wire of resistance R for time t. If i is halved i.e $i' = i/2$

H become $1/4$ th

21 D. Question

What is meant by the heating effect of current? Give two applications of the heating effect of current.

Answer

When electric current is supplied to a purely resistive conductor, the energy of electric current is dissipated entirely in the form of heat and as a result, resistor gets heated. The heating of resistor because of dissipation of electrical energy is commonly known as Heating Effect of Electric Current. Some examples are as follows:

When electric energy is supplied to an electric bulb, the filament gets heated because of which it gives light. The heating of electric bulb happens because of heating effect of electric current.

When an electric iron is connected to an electric circuit, the element of electric iron gets heated because of dissipation of electric energy, which heats the electric iron. The element of electric iron is a purely resistive conductor. This happens because of heating effect of electric current.

21 E. Question

Name the material which is used for making the filaments of an electric bulb.

Answer

Pure **tungsten** has some amazing properties including the highest melting point (3695 K), lowest vapor pressure, and greatest tensile strength out of all the metals. Because of these properties it is the most commonly used material for light bulb filaments.

Multiple Choice Questions (MCQs)-Pg-66

22. Question

The heat produced by passing an electric current through a fixed resistor is proportional to the square of:

- A. magnitude of resistance of the resistor
- B. temperature of the resistor
- C. magnitude of current
- D. time for which current is passed

Answer

The heat produced by passing an electric current through a fixed resistor is proportional to the square of magnitude of current.

As we know that, $H = V I t = I^2 R t$.

23. Question

The current passing through an electric kettle has been doubled. The heat produced will become:

- A. half
- B. double
- C. four times
- D. one-fourth

Answer

The current passing through an electric kettle has been doubled. The heat produced will become four times.

As $H = I^2 R t$

24. Question

An electric fuse works on the:

- A. chemical effect of current
- B. magnetic effect of current
- C. lighting effect of current
- D. heating effect of current

Answer

When the circuit current exceeds a specified value due to voltage fluctuations or short-circuiting, the fuse wire gets heated and melts.

25. Question

The elements of electrical heating devices are usually made of:

- A. tungsten
- B. bronze
- C. nichrome
- D. argon

Answer

An electric heating element is generally made from nichrome and can come in the shape of either a coil, ribbon or wire strip. When electricity is introduced into the heating element, its internal temperature increases and grows red hot as it begins to radiate heat outward

26. Question

The heat produced in a wire of resistance 'x' when a current 'y' flows through it in time 'z' is given by :

- A. $x^2 \times y \times z$
- B. $x \times z \times y^2$
- C. $y \times z^2 \times x$
- D. $y \times z \times x$

Answer

As $H = I^2 R t$

So, the heat produced in a wire of resistance 'x' when a current 'y' flows through it in time 'z' is given by $x \times z \times y^2$

27. Question

Which of the following characteristic is not suitable for a fuse wire?

- A. thin and short
- B. thick and short
- C. low melting point
- D. higher resistance than res of wiring

Answer

In electronics and electrical engineering, a fuse is a type of low resistance resistor that acts as a sacrificial device to provide over current protection, of either the load or source circuit.

28. Question

In a filament type light bulb, most of the electric power consumed appears as :

- A. visible light
- B. infra-red-rays
- C. ultraviolet rays
- D. fluorescent light

Answer

In a filament type light bulb, most of the electric power consumed appears as infra-red-rays.

29. Question

Which of the following is the most likely temperature of the filament of an electric light bulb when it is working on the normal 220 V supply line?

- A. 500° C
- B. 1500°C

C. 2500°C

D. 4500°C

Answer

The automated mass manufacturing of incandescent filaments intended for operation at over 2500 K is a significant technical achievement

30. Question

If the current flowing through a fixed resistor is halved, the heat produced in it will become:

A. double

B. one-half

C. one-fourth

D. four times

Answer

If the current flowing through a fixed resistor is halved, the heat produced in it will become one-fourth

As $H = I^2 Rt$

Questions Based on High Order Thinking Skills (HOTS)-Pg-67

31. Question

The electrical resistivities of four materials P, Q, R and S are given below :

P - $6.84 \times 10^{-8} \Omega \text{ m}$

Q - $1.70 \times 10^{-8} \Omega \text{ m}$

R - $1.0 \times 10^{15} \Omega \text{ m}$

S - $11.0 \times 10^{-7} \Omega \text{ m}$

Which material will you use for making:

(a) heating element of electric iron

(b) connecting wires of electric iron

(c) covering of connecting wires? Give reason for your choice in each case.

Answer

(a) The metals and alloy have very low resistivity in the range of 10^{-8} ohm meter to 10^{-6} ohm meter, so they are good conductor of electricity. While insulators have resistivity of the order of 10^{12} to 10^{17} ohm meter. Alloys have generally higher resistivity than its constituent metals and consider good for the heating elements. So S is used for heating element of electric iron.

(b) Q has very low resistivity of 1.7×10^{-8} ohm-m (it is actually copper). So it is used in connecting wires of electric iron.

(c) R has very high resistivity of 1.0×10^{15} ohm-m (it is actually rubber). So it is used for covering of connecting wires.

32 A. Question

How does the wire in the filament of a light bulb behave differently to the other wires in the circuit when the current flows ?

Answer

Because of the property of low melting point it behaves differently from the other wires.

32 B. Question

What property of the filament wire accounts for this difference?

Answer

This is because of the high resistance offered by filament wire.

33. Question

Two exactly similar heating resistances are connected (i) in series, and (ii) in parallel, in two different circuits, one by one. If the same current is passed through both the combinations, is more heat obtained per minute when they are connected in series or when they are connected in parallel? Give reason for your answer.

Answer

Resultant resistance in a series combination is greater than any individual resistance, and resultant resistance in a parallel combination is smaller than any individual resistance.

Since Heat is proportional to R ; so more the resistance, more the heat. Therefore, the resistances must be connected in series to obtain more heat per minute.

34. Question

An electric iron is connected to the mains power supply of 220 V. When the electric iron is adjusted at 'minimum heating' it consumes a power of 360 W but at 'maximum heating' it takes a power of 840 W. Calculate the current and resistance in each case.

Answer

To find the heat produced by iron in the problem, we need to use an expression for produced power, which depends on the resistance of the iron and the current flowing through the iron.

$$P_{\min} = VI$$

$$360 = 220I$$

$$I = 1.63 \text{ amp}$$

$$R = V/I$$

$$R = 220/1.63$$

$$R = 134.96\text{ohms}$$

In case of maximum heating we get

We know that

$$P_{\text{max}} = VI$$

$$840 = 220 \times I$$

$$I = 3.81\text{amp}$$

$$R = V/I$$

$$R = 220/3.81$$

$$R = 57.74\text{ohms}$$

35. Question

Which electric heating devices in your home do you think have resistors which control the flow of electricity?

Answer

Electric fuse, Room heater, Electric iron are some of the device which have resistor which control the flow of electricity