

## 4. Heredity and Evolution

### Very Short Answer Type Questions-Pg-191

#### 1. Question

Which of the processes, sexual reproduction or asexual reproduction, brings about maximum variations in the offspring?

#### Answer

Sexual Reproduction brings about maximum variations in the offspring because it involves fusion of gametes thus causing variations whereas asexual reproduction does not involve fusion of gametes so the offspring inherits genes from one parent only and thus variation is rare.

#### 2. Question

Name one variation in humans connected with ears.

#### Answer

Some humans have attached earlobes while some have free earlobes which is due to variation in genes.

#### 3. Question

What constitutes the link between one generation and the next?

#### Answer

Gametes form the link between one generation and the next because the hereditary information is present in the sex cells (gametes), Gametes pass on the parental (mother and father) traits to the offspring.

#### 5. Question

Mendel said that the characteristics or traits of organisms are carried from one generation to the next by internal factors which occur in pairs. What is the modern name for these factors?

#### Answer

These internal factors are known as genes. Genes are found in pairs on chromosomes and they carry traits from parents to the offspring.

#### 6. Question

Some plants occur in one of the two sizes: tall or dwarf. This characteristic is controlled by one pair of genes. Tallness is dominant to dwarfness. Choose

suitable letters for this gene pair.

**Answer**

Gene pair can be represented as Tt. T-Tallness-T and Dwarfness-t.(Dominant is always represented with a capital letter and recessive with a small letter).

**7. Question**

What are the chromosomes XY and XX known as?

**Answer**

These are known as the sex chromosomes. Females have XX as the set of sex chromosome whereas males have XY as the set of sex chromosome

**8. Question**

Which of the two, sperm or ovum, decides the sex of the child?

**Answer**

Sperm decides the sex of the child. During fertilization if X of the sperm fertilizes with egg (having one X chromosome) a girl child is born; if Y of the sperm fertilizes with egg a boy child is born.

**9. Question**

State whether the following statement is true or false:

**Answer**

The sex of an infant is not a case of inheritance of characteristics.

False, sex of an infant is case of inheritance of characteristics. Inheritance of characters determines the sex of an infant.

**10. Question**

A new born child has an XY pair of chromosomes. Will it be a baby boy or a baby girl?

**Answer**

The new born child will be a baby boy. The unfertilized egg has one X chromosome; the sperm either carries a X chromosome or a Y chromosome. If X of the sperm fertilizes with the egg the child born will be female (XX), and if Y of the sperm fertilizes with the egg the child born will be male (XY). Thus the new born child with an XY pair of chromosome will be a baby boy.

**11. Question**

Which of the following combinations of sex chromosomes produce a male child: XX or XY?

**Answer**

The Combination XY produces a male child. The unfertilized egg has one X chromosome. The sperm either has a X chromosome or a Y chromosome. Male child will be produced if sperm carrying Y chromosome fertilizes with the egg. Female child will be produced if sperm carrying X chromosome fertilized with the egg. Therefore, combination XY will produce a male child.

**12. Question**

Name the first scientist who studied the inheritance of traits from one generation to the next.

**Answer**

Gregor Johann Mendel studied the inheritance of traits from one generation to the next. He discovered basic principles of heredity through his experiments on pea plant.

**13. Question**

What type of plants were used by Mendel for conducting his experiments on inheritance?

**Answer**

Mendel used pea plant for conducting experiments on inheritance. Reasons for selecting pea plant were

- a) they are easy to raise
- b) give many offspring per mating
- c) self-fertilization
- d) have varieties in genotype and phenotype.

**14. Question**

The gene for red hair is recessive to the gene for black hair. What will be the hair color of a person if he inherits a gene for red hair from his mother and a gene for black hair from his father ?

**Answer**

Black hair color; it is because gene for black hair color is dominant so it will be expressed and since gene for red hair is repressive so it will be suppressed under the influence of black hair gene.

**15. Question**

What are the four blood groups in humans?

**Answer**

The four blood groups in humans are blood group A, B, AB and O. The ABO blood group system was given by Karl Landsteiner in 1900. He identified the blood types O, A and B.

### 16. Question

Name one reptile in each case where higher incubation temperature leads to the development of:

- (a) Male progeny,
- (b) Female progeny.

### Answer

- (a) Incubation of eggs Lizard (Agama agama) at high temperature produces male progeny.
- (b) Incubation of eggs of Turtle (Chrysema Picta) at high temperature produces female progeny.

### 17. Question

Fill in the following blanks with suitable words :

- (a) Genes always work in .....
- (b) In pea plants, the gene for dwarfness is.....whereas that for tallness is.....
- (c) Most people have .....earlobes but some have .....earlobes.
- (d) A human gamete contains..... chromosomes whereas a normal body cell has ..... chromosomes in it.
- (e) All races of man have.....blood groups.
- (f) The.....chromosomes for a .....are XX whereas that for a .....are XY.

### Answer

- (a) Pair
- (b) Recessive; Dominant.
- (c) Free; Attached.
- (d) 23; 46
- (e) Same
- (f) Sex; Female; Male.

### 18. Question

Which of the following represent tall plants and which represent short plants (or dwarf plants)?

(a) Tt (b) tt (c) TT

Give reason for your choice (The symbols have their usual meaning).

#### Answer

Tt- represents tall plant. This is because T is dominant so it is expressed and since t is recessive, it gets suppressed. (Where T=tall plant; t= dwarf plant)

tt- represents dwarf plant. This is because both the genes for determining the height of the plant are recessive and none of the dominating genes are present.

TT- represents tall plant. This is because T is dominant gene for height and both the dominant genes are present.

### 19. Question

A man having blood group O marries a woman having blood group B and they have a daughter. What will be the blood group of the daughter?

#### Answer

There are equal possibilities of the daughter having blood group O and B.

Blood group O will have O and O genes whereas blood group B will have B gene as dominant and O as recessive so the gene pairs that could be formed will be either O and B or O and O ; either B and O or O and O. Hence the equal possibility i.e. 50-50.

### 20 A. Question

Name the scientist who gave the laws of inheritance.

#### Answer

(A) Gregor Johann Mendel gave the laws of inheritance. He studied heredity on pea plants and gave three laws of inheritance. 1. Law of Dominance. 2. Law of segregation. 3. Law of independent assortment.

### 20 B. Question

Name an animal in which individuals can change sex. What does this indicate?

#### Answer

(B) Snail can change sex amongst its individuals. It is usually done among the endangered snail species in order to keep themselves Alive. This indicates that genes do not play a role in determining the sex of the individual.

## 21. Question

Explain with an example, how genes control the characteristics (or traits).

### Answer

Genes are the units of heredity i.e. they transfer characteristics from parents to offspring and determine the characteristics of the offspring. Example- Transfer of hair color from parents to the offspring. Let's say that the mother has dominant genes for black hair, (BB gene constitution) and the father has recessive gene for blonde hair (bb gene constitution). When fertilization will occur the mother will transfer one B gene for black hair to the zygote and the father will transfer one b gene for blonde hair to the zygote. The resulting offspring will have Bb gene for hair where B is a dominant gene and b is a recessive gene. Since B is dominant it will be expressed and b will be suppressed, the child will have black hair.

## 22 A. Question

State one advantage of variation to a species.

### Answer

(A) Variations are heritable differences within individuals of a species. Advantage- Nature always selects the fittest organism so if no variation occurred in genes there would not have been so many species of the organism. In a changing environment, variation always increases the chances of survival of a species.

## 22 B. Question

What are sex chromosomes? How many sex chromosomes are there? Name them.

### Answer

(B) Sex chromosomes are a pair of chromosome that decide/determine the sex of an individual. The 23<sup>rd</sup> pair of chromosome is Allosome (or sex chromosome).

There are 2 sex chromosomes (one pair). X and Y chromosome. Y chromosome is found only in males. X chromosome is found in both male and female

## 23. Question

Explain how, sex is determined in human babies.

### Answer

The unfertilized egg has one X chromosome. The sperm either has a X chromosome or a Y chromosome. If sperm carrying Y chromosome fertilizes with the egg, male baby will be born with the genetic constitution XY. But if

sperm carrying X chromosome fertilized with the egg, female baby will be born with the genetic constitution XX.

## 24. Question

What do the following symbols used in the topic on heredity represent?

(a) TT (b) tt

(c) XX (d) XY

### Answer

(a) TT – Tall plant (T is a dominant gene).

(b)tt- dwarf plant (t is a recessive gene and there is no dominant gene to rule over it so dwarf height).

(c)XX- Female. (Female have both the sex chromosome as X X).

(d)XY- Male. (Male have One X chromosome and the other is Y chromosome as their sex chromosome).

## 25 A. Question

What will you get in the F<sub>1</sub> and F<sub>2</sub> generations in the following cross ? Pure tall pea plant x pure dwarf pea plant?

### Answer

(A) In the F<sub>1</sub> generation we will get all tall plants with Tt gene combination and in the F<sub>2</sub> generation we will get 3 tall plants (TT/Tt) and one dwarf plant (tt).

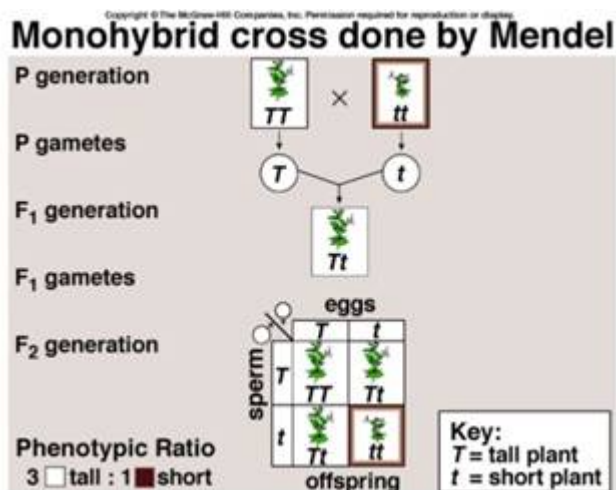

## 25 B. Question

Is it an example of monohybrid cross or dihybrid cross?

### Answer

(B) This is an example of a monohybrid cross because there is just one trait i.e. height whose inheritance pattern is being studied.

## 26. Question

In the F<sub>2</sub> generation of a cross, progeny having different traits are produced in the ratio 3 : 1. State whether it is a monohybrid cross or a dihybrid cross? Give one example of such a cross.

### Answer

It is a monohybrid cross. A monohybrid cross is a cross between two individuals with two different alleles on one gene. It produces a phenotypic monohybrid ratio of 3:1 in the F<sub>2</sub> generation. Whereas a Dihybrid cross produces a phenotypic Dihybrid ratio of 9:3:3:1 in the F<sub>2</sub> generation.

For example- When pure tall plant (TT) are crossed with pure dwarf plants (tt), the offspring of the F<sub>1</sub> generation is all tall plants (Tt). When these Tall plants cross bred with each other, they produce 'TT' 'Tt' 'Tt' 'tt' offspring i.e. tall : short = 3:1. The phenotypic monohybrid ratio in the F<sub>2</sub> generation is 3:1.

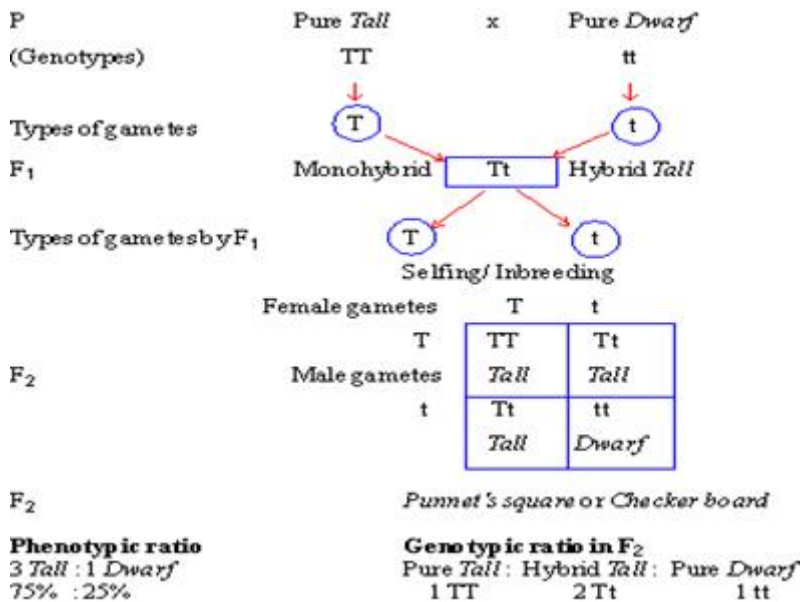

## 27 A. Question

What is the genotype of dwarf plants which always produced dwarf offspring ?

### Answer

(A) Dwarf-ness is denoted by letter 't'. For plants that have always produced dwarf offspring, the genotype will be 'tt' as dwarf-ness will only be expressed when both the genes are recessive i.e. 'tt'

## 27 B. Question

What is the genotype of tall plants which always produced tall offspring?

### Answer



(B) Tallness is denoted by letter 'T'. For plants that have always produced tall offspring, the genotype will be TT. It can also be Tt because since dominant gene T is present it will not let the recessive trait i.e. dwarf-ness express itself.

### 27 C. Question

What is the genotype of (i) dwarf plants, and (ii) tall plants, whose parental cross always produces tall offspring?

#### Answer

(C) (i) Genotype of dwarf plants will be 'tt' because dwarf-ness is a recessive trait that is expressed only when both the genes are recessive.

(ii) Genotype of tall plant will be 'TT' because the parental cross is producing tall offspring always.

### 28 A. Question

If a normal human cell has 46 chromosomes, how many chromosomes will be there in a human (i) sperm cell, and (ii) zygote?

#### Answer

(A) (i) sperm cell will have 23 chromosomes as gametes consist of half the number of chromosome of somatic cells.

(ii) Zygote will have 46 chromosomes as 23 chromosomes from the gamete of mother (egg) and 23 chromosome from the gamete of the father (sperm) will fuse to a total of 46 chromosomes.

### 28 B. Question

(b) What sizes of plants are produced if both parents have genes Tt?

#### Answer

(b) When both parents have same genes Tt and Tt and they are made to cross bred, we get a phenotypic ratio of 3:1 of tall: dwarf. (TT, Tt, Tt, tt)

### 29. Question

In a human, how many chromosomes are present in:

(a) a brain cell ?

(b) a sperm in the testes ?

(c) an egg which has just been produced by the ovary?

(d) a skin cell ?

(e) a fertilized egg ?

**Answer**

- (a) 46 (23 pairs of chromosome)
- (b) 23 chromosomes (haploid)
- (c) 23 chromosomes (haploid)
- (d) 46 chromosomes (23 pairs of chromosome)
- (e) 46 chromosomes (since it is fertilized by the sperm)

**30. Question**

Gregor Mendel's first law of genetics states "Of a pair of contrasted characters, only one can be represented in a gamete by its internal 'factor'".

- (a) Give the modern name for this 'factor'.
- (b) State where these factors are found in gametes.

**Answer**

(a) This factor is known as Genes. They are unit of heredity transferred from parents to offspring. Each parent has a gene pair in each cell for each trait studied. One member of the gene pair segregates into a gamete, thus each gamete only carries one member of the gene pair and hence only one out of a pair of contrasted characters is represented in a gamete by its gene.

(b) These internal factors known as genes are found on chromosomes which are made of DNA and protein and found in the nucleus of the cell.

**31. Question**

Does genetic combination of mother play a significant role in determining the sex of a new born baby?

**Answer**

No, the genetic constitution of mother does not play a significant role in determining the sex of baby. This is because mother has 2 X sex-chromosomes (i.e. XX) so the baby will inherit an X chromosome from the mother. It is the father whose genetic constitution plays important role. Father has XY sex chromosomes so the baby will either inherit X chromosome or Y chromosome through sperm. If the sperm carries X chromosome the baby born will be a girl (XX) and if the sperm carries Y chromosome the baby born will be a boy (XY).

**32. Question**

Give the contrasting traits of the following characters in pea plant and mention which is dominant and which is recessive:

- (a) Yellow seed (b) Round seed

## **Answer**

(a) Green seed is the contrasting trait of yellow seed where Green is recessive and yellow is dominant.

(b) Wrinkled seed is the contrasting of round seed where Wrinkled is recessive and round is dominant.

## **Long Answer Type Questions-Pg-192**

### **33 A. Question**

What is meant by 'heredity' ? What are the units of heredity?

#### **Answer**

(A) Heredity refers to passing on of traits/characters genetically from parents to offspring.

The units of heredity are genes which are found on chromosomes. Chromosomes are organized structures of DNA and protein and are found in the nucleus.

### **33 B. Question**

State Mendel's first law of inheritance.

#### **Answer**

(B) Mendel's first law of inheritance is Law of Segregation which states that gene determines the characteristics/traits of an organism which always occur in pairs. One member of the gene pair segregates into a gamete.

### **34 A. Question**

Why did Mendel choose pea plants for conducting his experiments on inheritance?

#### **Answer**

(A) Mendel choose pea plant for conducting his experiments on inheritance because they are easy to raise and are self-pollinating too. Also many generations can be produced in a lesser time.

### **34 B. Question**

State Mendel's second law of inheritance.

#### **Answer**

(B) Mendel's second law of inheritance is also known as law of independent assortment which states that in inheritance of more than one pair of traits in a cross simultaneously, the factors responsible for each pair of traits are distributed independently to the gametes.

### 35 A. Question

What do you understand by the term 'variation'?

#### Answer

(A) The difference between groups of organism of any specie that is brought about by genetic differences is known as variation.

### 35 B. Question

Name two human traits which show variation.

#### Answer

(B) Human height (Tall or dwarf) and Ear lobe (free or attached) show variations in human.

### 35 C. Question

How does the creation of variation in a species ensure its survival?

#### Answer

(C) Nature always selects the fittest organism so if no variation occurred in genes there would not have been so many species of the organism. Variation always increases the chances of survival of a species in a changing environment. For example- bacteria having heat resistant trait will survive when temperature rises too much, and bacteria that do not have this heat resistant trait will die when temperature in their surrounding rises too much.

### 36 A. Question

(a) What are genes? Where are they located in our body?

#### Answer

(A) Genes are the units of heredity that transfer characteristics/traits from parent to offspring. They are found on chromosomes in our body and chromosomes are found in nucleus of the cell.

### 36 B. Question

(b) What is meant by dominant genes and recessive genes? Give one example of each.

#### Answer

(B) A dominant gene is a gene that is expressed or appears in an organism in the presence of any another gene. Whereas, a recessive gene is a gene that is suppressed in an organism (doesn't appears) in the presence of a dominant gene. A recessive gene is expressed or appears in an organism only if the other gene present is recessive.

Example- Height in Pea plant. Tall Plants may have gene combination of TT or Tt. (where T is a dominant gene). Dwarf plants will only have gene combination of tt (where t is a recessive gene)

### 36 C. Question

(c) Explain how, characteristics (or traits) are inherited through genes.

#### Answer

(C) Genes are unit of heredity transmitted from parents to offspring. Each parent has a gene pair in each cell for each characteristic studied. One member of the gene pair segregates into a gamete, thus each gamete only carries one member of the gene pair from each parent and hence only one out of a pair of contrasted characters is represented in a gamete by its gene. When sperm fertilizes the egg, they form a zygote which develops to an organism having characteristics from both the parents which it would have inherited in the gametes through segregation.

### 37 A. Question

How do Mendel's experiments show that traits may be dominant or recessive?

#### Answer

(A) In his experiment with Pea Plant, Mendel crossed pure tall plants (TT) with pure dwarf plants (tt) and he obtained all tall plants in the F1 generation (Tt) which suggested that only one of the traits of parental plant showed in the F1 generation i.e. tall.

He crossed these tall plants of F1 generation amongst each other and obtained tall and dwarf plants in the ratio of 3:1 as the second generation (F2 generation). So he observed that the dwarf trait that had disappeared in the F1 generation reappear in the Second generation (F2 generation). Thus this shows that the traits may be dominant or recessive.

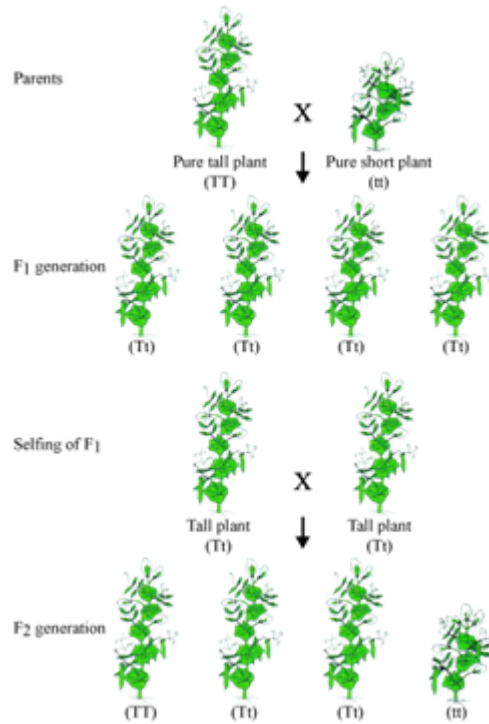

F<sub>2</sub> generation- 3 tall:1 dwarf (Tt:tt)

### 37 B. Question

How do Mendel's experiments show that traits are inherited independently?

#### Answer

(B) Mendel performed another experiment with Pea plants, this time taking two traits into consideration, yellow round seeds and green wrinkled seeds. He crossed these two plants and in the F<sub>1</sub> generation and obtained all yellow round seeds. Yellow and round were dominant so they were expressed and Green and wrinkled were recessive so they remain suppressed. He self-pollinated these F<sub>1</sub> generation plants to produce F<sub>2</sub> generation and found yellow round seeds, green wrinkled seeds. Also he found yellow wrinkled seeds and green round seeds. Thus this experiment showed that the traits are inherited independently.

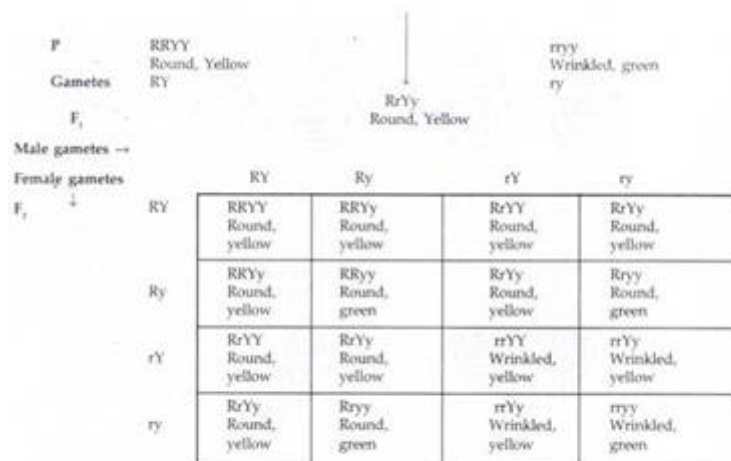

Fig. 5.15. Results of a dihybrid cross between pure breeding plants with round, yellow and wrinkled, green seeds and Mendel's explanation for the mode of inheritance.

### 38. Question

When two parents are crossed, the offspring are referred to as :

- A. Recessive
- B. Test cross
- C. F<sub>1</sub> generation
- D. F<sub>2</sub> generation

### Answer

F<sub>1</sub> generation

Filial Generation of the offspring of parental (mother and father) type. Filial means offspring of a cross.

### 39. Question

A cross between two individuals results in a ratio of 9: 3: 3 : 1 for four possible phenotypes of progeny. This is an example of a;

- A. Dihybrid cross
- B. Monohybrid cross
- C. Test cross
- D. None of these

### Answer

Dihybrid Cross.

Cross between two individual involves two pairs of heterozygous genes giving a ratio of 9:3:3:3 (theoretical).

### 40. Question

For his experiments on heredity, Mendel used:

- A. Papaya plants
- B. Potato plants
- C. Pea plants
- D. Pear plants

### Answer

Pea Plants

Mendel selected pea plants because they are easy to raise, they give many offspring per mating; they fertilize on their own and have varieties in genotype and phenotype

#### **41. Question**

The human animal which has an XY pair of chromosomes is called:

- A. Male
- B. hybrid
- C. Female
- D. doomed

#### **Answer**

Male

Sperm with Y chromosome fertilizes with egg (having one X chromosome) thus producing a male with XY pair of chromosome.

#### **42. Question**

The science of heredity is known as:

- A. Biology
- B. Embryology
- C. Genetics
- D. Biochemistry

#### **Answer**

Genetics

Heredity is passed on through genes.

#### **43. Question**

A gene is a:

- A. Hybrid
- B. Heritable trait
- C. Pure breed
- D. Part of a chromosome that transmits a trait.

#### **Answer**

Part of a chromosome that transmits a trait



Gene is present in pairs on chromosome and they transmit characteristics to offspring from parent.

#### 44. Question

A normal cell of human body contains 23 pairs of chromosomes. The number of chromosomes in a sex cell

(Sperm or ovum) of a human being is most likely to be:

- A. 46
- B. 23
- C. 21
- D. 42

#### Answer

23

Somatic cells have 46 chromosomes (23 pairs of chromosome) i.e., they are diploid. The chromosome number is haploid in sex cells so they have 23 chromosomes.

#### 45. Question

In order to ensure that he had pure-breeding plants for his experiments, Mendel:

- A. Cross-fertilized each variety with each other
- B. Let each variety self-fertilize for several generations
- C. Removed the female parts of the plants
- D. Removed the male parts of the plants.

#### Answer

Let each variety self-fertilize for several generation

#### 46. Question

In the human blood grouping, the four basic blood types are type A, type B, type AB, and type O. The blood proteins A and B are:

- A. Simple dominant recessive traits
- B. Incomplete dominant traits
- C. Co-dominant traits
- D. Sex-linked traits

### Answer

Co-dominant traits

### 47. Question

A plant with two 'small' genes breeds with a plant with two 'tall' genes to produce:

- A. Small plants and tall plants in the ratio 1:3
- B. All small plants
- C. All tall plants
- D. Tall plants and small plants in the ratio 3:1

### Answer

All tall plants; When two small genes plant 'tt' breeds with two tall genes plant 'TT' they result in four combinations of all 'Tt' genes, where T is dominant and it suppresses the recessive gene t ; so all plants will be tall .

### 48. Question

A pregnant woman has an equal chance of her baby being blood group A or blood group AB. Which one of the following shows the possible genotypes of the woman and the father of her child?

- A.  $I^A I^A$  and  $I^B I^O$
- B.  $I^A I^B$  and  $I^B I^O$
- C.  $I^A I^O$  and  $I^B I^O$
- D.  $I^A I^B$  and  $I^A I^O$

### Answer

$I^A I^A$  and  $I^B I^O$ .  $I^A I^A$  will express Blood Type A.  $I^B I^O$  will either express blood type B or O. Since O are always recessive then the resulting combinations from where they are inherited are blood type AB or blood type O.

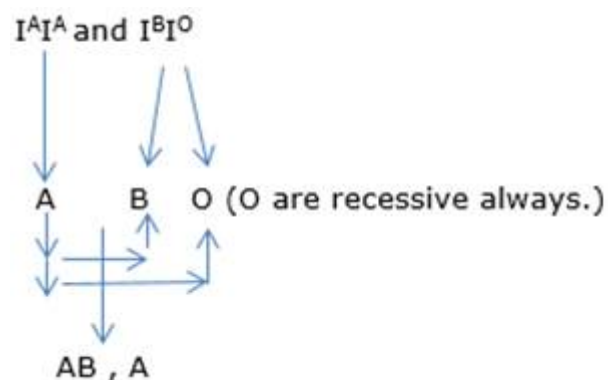

#### 49. Question

The palisade cells of a species of plant contain 28 chromosomes. How many chromosomes will there be in each gamete produced by the plant?

- A. 56
- B. 28
- C. 14
- D. 4

#### Answer

14

Palisade cells are somatic cells and gamete cell contain half the number of chromosome has in its somatic cells. So  $28/2=14$ .

#### 50. Question

Which of the following may be used to obtain an F<sub>2</sub> generation?

- A. Allowing flowers a parent plant to be self-pollinated
- B. Allowing flowers on an F<sub>1</sub> plant to be self-pollinated
- C. Cross-pollinating an F<sub>1</sub> plant with a parent plant
- D. Cross-pollinating two parent plants

#### Answer

Allowing flowers a parent plant to be self-pollinated.

Self-pollination of F<sub>1</sub> progeny will lead to F<sub>2</sub> progeny as it happens in monohybrid and Dihybrid crosses.

#### 51. Question

The following results were obtained by a scientist who crossed the F<sub>1</sub> generation of pure-breeding parents for round and wrinkled seeds.

Dominant trait -Round seeds

Recessive trait -Wrinkled seeds

No. of F<sub>2</sub> offspring -7524

From these results, it can be concluded that the actual number of round seeds he obtained was:

- A. 1881

B. 22572

C. 2508

D. 5643

**Answer**

5643; When Round 'RR' and wrinkled 'rr' seed bearing plants are crossed, all heterozygous round seed bearing plants are obtained in the F1 generation. When the plants of these F1 generations are cross bred, the F2 generation had round and wrinkled seed bearing plant in the ratio 3:1. (total=4)

Hence,  $(\frac{3}{4}) * 7524 = 5643$

**52. Question**

The visible characteristic in an organism is known as:

A. Prototype

B. stereotype

C. Phenotype

D. genotype

**Answer**

Phenotype

It is defined as visible characteristics of an individual which occur from the interaction of its genotype with the environment.

**53. Question**

The exchange of genetic material takes place in:

A. Vegetative reproduction

B. Asexual reproduction

C. Sexual reproduction

D. Budding

**Answer**

Sexual reproduction

Sexual reproduction involves fusion of gametes which results in exchange of genetic material.

**54. Question**

A cross between a tall plant (TT) and short plant (tt) resulted in progeny that were all tall plants because :

- A. Tallness is the dominant trait
- B. Shortness is the dominant trait
- C. Tallness is the recessive trait
- D. Height of plant is not governed by gene T or t

**Answer**

Tallness is the dominant trait.

When a cross between tall plant TT and a short plant tt occurs , the resulting offspring are all 'Tt' where T is the dominant trait so all plants are tall due to that dominant trait which does not lets the recessive trait i.e. shortness express itself.

**55. Question**

The number of pair(s) of sex chromosomes in the zygote of humans is:

- A. One
- B. Two
- C. Three
- D. Four

**Answer**

One. XX chromosome in female; XY chromosome in male.

**56. Question**

In peas, a pure tall plant (TT) is crossed with a pure short plant (tt). The ratio of pure tall plants to pure short plants in F<sub>2</sub> generation will be:

- A. 1 : 3
- B. 3 : 1
- C. 1 : 1
- D. 2 : 1

**Answer**

1:1

When pure tall plant TT is crossed with pure short plant tt, all 'Tt' offspring are obtained in the F<sub>1</sub> generation. When selfing of these F<sub>1</sub> generation plants

is done, the offspring obtained are 'TT' 'Tt' 'Tt' 'tt'- in the ratio 3:1 (Tall : short), where pure tall plant and pure short plant are in the ratio 1:1(TT and tt).

### 57. Question

The two versions of a trait (character) which are brought in by the male and female gametes are situated on:

- A. Copies of the same chromosome
- B. Sex chromosomes
- C. Two different chromosomes
- D. Any chromosomes

### Answer

Copies of the same chromosome

These versions of traits are known as genes which when brought in by the male and female gametes are found on copies of same chromosome so that they do not assort independently and are said to be linked.

### 58. Question

Select the statements that describe characteristics of genes:

- (i) genes are specific sequence of bases in a DNA molecule
  - (ii) a gene does not code for proteins
  - (iii) in individuals of a given species, a specific gene is located on a particular chromosome
  - (iv) each chromosome has only one gene
- A. (i) and (ii)
  - B. (i) and (iii)
  - C. (i) and (iv)
  - D. (ii) and (iv)

### Answer

(i) and (iii)

Genes are specific sequences of bases that are present on chromosomes found in nucleus of DNA.

### 59. Question

Select the group which shares the maximum number of common characters:

- A. Two individuals of a species
- B. Two species of a genus
- C. Two genera of a family
- D. Two genera of two families

**Answer**

Two individuals of a species

Species is the lowest taxonomic category and share common features, thus two individuals of a species share maximum no. of characters (share common gene pool).

**60. Question**

A trait in an organism is influenced by:

- A. Paternal DNA only
- B. Maternal DNA only
- C. Both maternal and paternal DNA
- D. Neither paternal, nor maternal DNA

**Answer**

Both maternal and paternal DNA

This is because the gametes coming from the mother and father have genes that carry different traits. When these gametes fuse, the traits are mixed and expressed accordingly.

**61. Question**

In human males all the chromosomes are paired perfectly except one. This /these unpaired chromosome is/are:

- (i) Large chromosome
- (ii) Small chromosome
- (iii) Y chromosome
- (iv) X chromosome

- A. (i) and (ii)
- B. (iii) only
- C. (iii) and (iv)

D. (ii) and (iv)

**Answer**

(iii) and (iv) Y chromosome and X chromosome

Males have all 22 pairs of chromosomes paired perfectly. The 23<sup>rd</sup> pair of chromosome that is the pair of sex chromosomes are not paired perfectly because in the pair one chromosome is X and the other is Chromosome Y , so they are not paired perfectly.

**62. Question**

The sex of a child is determined by which of the following?

- A. The length of the mother's pregnancy
- B. The length of time between ovulation and copulation
- C. The presence of an X chromosome in an ovum
- D. The presence of a Y chromosome in a sperm

**Answer**

The presence of Y chromosome in sperm.

If sperm carries a Y chromosome and fertilizes with egg (having an X chromosome) the sex of the child will be male. But if the sperm carries a X chromosome and fertilizes with egg the sex of the child will be female.

**63. Question**

A zygote which has inherited an X chromosome from the father will develop into :

- A. Baby boy
- B. Baby girl
- C. Adult
- D. Either boy or girl

**Answer**

Baby Girl

The mother already has X chromosome in the unfertilized egg. When a sperm, carrying X from the father will fertilize the egg, the combination would be XX and thus a baby girl will develop.

**64. Question**

Which of the following statement is incorrect?



- A. For every hormone there is a gene
- B. For every protein there is a gene
- C. For production of every enzyme there is a gene
- D. For every type of fat there is a gene

**Answer**

For every type of fat there is a gene

For every hormone production, every protein formation and for production of every enzyme, genes exist but no such genes exist for fat. So the statement (d) is incorrect. Fat is a kind of Acquired characteristic.

**65. Question**

If the ratio of each phenotype of the seeds of pea plants in the F<sub>2</sub> generation is 9 : 3 : 3 : 1, it is known as :

- A. Tetra hybrid ratio
- B. Monohybrid ratio
- C. Dihybrid ratio
- D. Tri hybrid ratio

**Answer**

Dihybrid cross

Ratio in F<sub>2</sub> generation of a Dihybrid cross is always 9:3:3:1

**Questions Based on High Order Thinking Skills (HOTS)-Pg-195**

**66. Question**

In humans, if gene B gives brown eyes and gene b gives blue eyes. What will be the color of eyes of the persons having the following combination of genes?

- (a) Bb (b) bb (c) BB

**Answer**

(a)Bb-Brown eyes.(B is dominant which gives brown eyes)

(b)bb-Blue eyes.(b is recessive which gives blue eyes and none dominant gene present)

(c)BB-Brown eyes.(B is dominant which gives brown eyes)

**67. Question**

Pure-bred pea plants A are crossed with pure-bred pea plants B. It is found that the plants which look like A do not appear in  $F_1$  generation but re-emerge in  $F_2$  generation. Which of the plants A and B are : (i) tall, and (ii) dwarf? Give reason for your answer.

**Answer**

(i) tall- B plant

(ii) dwarf- A plant.

This is because only tall plants appear in the  $F_1$  generation and dwarf plants appear in the  $F_2$  generation along with tall plants.

**68. Question**

Pure-bred tall pea plants are first crossed with pure-bred dwarf pea plants. The pea plants obtained in  $F_1$  generation are then cross-bred to produce  $F_2$  generation of pea plants.

(a) What do the plants of  $F_1$  generation look like ?

(b) What is the ratio of tall plants to dwarf plants in  $F_2$  generation?

(c) Which type of plants were missing in  $F_1$  generation but reappeared in  $F_2$  generation?

**Answer**

(a) Tall plants

(b) 3:1

(c) Dwarf plants.

**69. Question**

A plant has two varieties, one with red petals and the other with white petals. When these two varieties are cross-pollinated, all the offspring have red petals?

(a) Which gene is dominant?

(b) Choose suitable letters to represent the two genes.

**Answer**

(a) Red color (Dominancy means ruling over the other)

(b) R and r (R for Dominant and r for recessive)

**70. Question**

A red-haired woman marries a brown-haired man, and all the children are brown haired. Explain this genetically.

### Answer

Brown hair color genes are dominant and the red hair color genes are recessive ; The genotype of brown hair is BB (dominant always represented by capital letter) and that of red hair bb (Recessive represented by small letter)

### 71. Question

A black mouse mates with a brown mouse, and all the offspring are black.

(a) Why are no brown off springs produced?

(b) If two of the black offspring mate with each other what kind of offspring would you expect and in what proportions? Give reason for your answer.

### Answer

(a) No brown offspring are produced because brown color is recessive here and black being dominant rules.

(b) Three black mice and one brown mouse will be obtained in F<sub>2</sub> generation; It is a monohybrid cross(Punnett Square)

### 72. Question

(a) E is the gene for brown eye color and e is the gene for blue eye color. Which gene is

(i) Recessive, and

(ii) Dominant

(b) Both father and mother have the genes Ee in their cells. What color are their eyes?

(c) Which combination of genes in the zygote will produce children with blue eyes?

(d) Which combinations of genes in the zygote will produce children with brown eyes?

### Answer

(a) (i) e blue color gene is recessive; recessive is always represented by small letters.

(ii) E brown color gene is dominant; dominant is always represented by capital letters.

(b) They have **brown eye color** because dominant gene for brown eye color is present which suppresses the recessive gene for blue eye color and hence

brown eye color is expressed

(c) Combination of **ee** will produce children with blue eyes because for blue eye color to be expressed there should not be gene for brown eye color that is E because if E gene will be present it will dominate the eye color and then brown eye color will be expressed and if there will be no dominant gene i.e. ee then the eye color expressed will be blue.

(d) The combinations **EE** and **Ee** will produce children with brown eyes because for brown eyes to be expressed there must be at-least one dominant gene for brown eye color i.e. E be present.

### 73. Question

What are the possible blood groups likely to be inherited by children born to a group A mother and a group B father? Explain your reasoning.

#### Answer

The possible genotype that will be inherited by the children when the mother is group A and the father is group B are  $I^A I^B$ ,  $I^A I^O$ ,  $I^B I^O$  and  $I^O I^O$ . The possible blood group likely to be inherited will be either AB, A, B and O

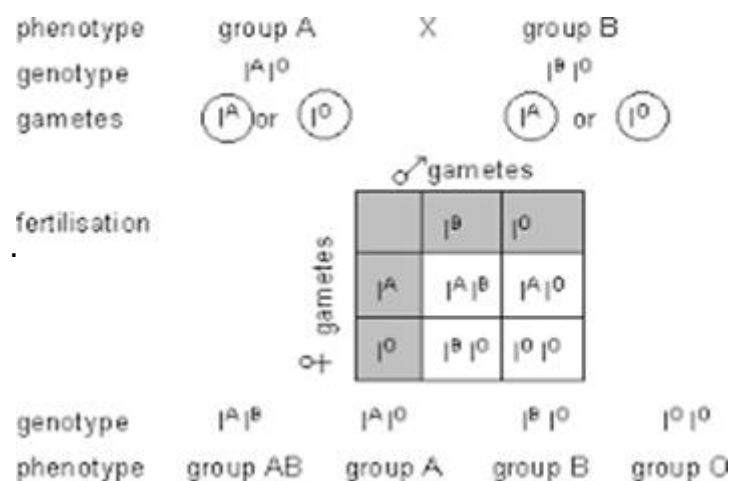

### 74. Question

A couple with a newborn baby is troubled that the child does not resemble either of them. Suspecting that a mix-up occurred at the hospital, they check the blood type of the infant. It is type O. Because the father is type A and the mother type B, they conclude that a mix-up has definitely occurred. Are they correct? Give reason for your answer

#### Answer

No, the parents are not correct. The father is type A and the Mother is type B; the possible genotypes that are inherited by the baby are  $I^A I^B$ ,  $I^A I^O$ ,  $I^B I^O$  and  $I^O I^O$ . This means that any of the blood type AB, A, B, and O can be inherited by the child. If the child inherits any of the one blood type, which is occurring here in this case that the child is inheriting type O blood group, no error has occurred.

### 75. Question

A man with blood group A marries a woman with blood group O and their daughter has blood group O. Is this information enough to tell you which of the traits - blood group A or O - is dominant? Why or why not?

### Answer

Case 1: Man with blood group A married a woman with blood group B. Blood group for man can be expressed by dominant genotype  $I^A I^A$  or  $I^A I^O$  and blood group O for woman is expressed by recessive genotype  $I^O I^O$ . The daughter will have O blood group type as a result of this  $I^O I^O$  inheritance of recessive traits from mother and father.

Case 2: Blood group A in father if has recessive genotype  $I^A I^A$  and mother has dominant genotype  $I^A I^O$  or  $I^O I^O$ . The daughter will have O blood type as a result of inheritance of dominant allele  $I^O$  from mother and recessive allele  $I^A$  from father.

Blood group A is expressed in both homozygous and heterozygous condition but Blood group O is expressed in recessive condition.

### 76. Question

A Mendelian experiment consisted of breeding tall TT pea plants bearing violet flowers with short t pea plants bearing white w flowers. The progeny all bore violet W flowers, but almost half of them were short. This suggested that the genetic make-up (or genotype) of the tall parent can be depicted as:

- (a) TTWW
- (b) TTww
- (c) TtWW
- (d) TtWw

Give reason for your choice

### Answer

The genetic makeup of the tall parent can be depicted as (C) TtWW. As the question says, Tall Pea plants bearing violet flowers; Tallness is a dominant trait and is always represented by capital letters so 'T' and short/dwarfness is represented by small letters so 't' – hence Tt. Violet Flowers is a dominant trait and is represented by capital letters so 'W'. The progeny had short plants but no white flowers which means that Violet flowers are being passed on. Therefore, the genotype of the tall parent can be depicted as TtWW. There is a dominant gene for tallness which suppresses the recessive gene for height and for all violet flowers were present in tall pea plant.

### 77. Question

A person first crossed pure-bred pea plants having round-yellow seeds with pure-bred pea plants having wrinkled-green seeds and found that only A-B

type of seeds were produced in the  $F_1$  generation. When  $F_1$  generation pea plants having A-B type of seeds were cross-bred by self-pollination, then in addition to the original round-yellow and wrinkled-green seeds, two new varieties A-D and C-B type of seeds were also obtained.

- (a) What are A-B type of seeds?
- (b) State whether A and B are dominant traits or recessive traits.
- (c) What are A-D type of seeds?
- (d) What are C-B type of seeds?
- (e) Out of A-B and A-D types of seeds, which one will be produced in
  - (i) minimum numbers, and
  - (ii) maximum numbers, in the  $F_2$  generation ?

### Answer

(a) Round Yellow.

Round yellow- RRYy, wrinkled green-rryy. On crossing these two pea plants we get RrYy combination which has dominant gene R for Round shape and Dominant gene Y for yellow color. Hence A-B types of seed produced as a result of the first cross are Round yellow.

(b) A and B are dominant traits since they are Round (R) and yellow (Y)

(c) Round-green

When RrYy obtained in the first generation is self-pollinated, the new varieties obtained are RY, Ry, rY, ry; where RY- Round yellow, Ry-Round green, rY-Wrinkled yellow, and ry- wrinkled green. Since A-B type of seed is Round and yellow, therefore A-D type of seed is Round and Green.

(d) Wrinkled-yellow

When RrYy obtained in the first generation is self-pollinated, the new varieties obtained are RY, Ry, rY, ry; where RY- Round yellow, Ry-Round green, rY-Wrinkled yellow, and ry- wrinkled green. Since A-B type of seed is Round and yellow, therefore C-B type of seed is wrinkled and yellow.

(e)(i) A-D (Round and green 'Ry' will be produced in minimum number)

(ii) A-B (Round and yellow 'RY' will be produced in maximum number in  $F_2$  generation)

### 78. Question

The person A has only B chromosomes in all its gametes. On the other hand, another person C has chromosome D in half of gametes and chromosome E in the other half of gametes. When chromosomes B and D combine during

fertilization, a female zygote results. On the other hand, combination of B and E chromosomes produces a male zygote.

(a) What are chromosomes?

(i) B

(ii) D, and

(iii) E ?

(b) Out of B, D and E, which two chromosomes are of the same type?

(c) Which chromosome is smaller in size?

(d) What is the general name of chromosomes such as B and E?

(e) Out of the two persons A and C, which one is

(i) male, and

(ii) female ?

### **Answer**

(a) (i) The chromosome B are X chromosomes because if person A is entirely made up of B chromosomes it means the person is a female and has all X chromosomes.

(ii) The chromosome D is X chromosome again because when B and D combine a female offspring is produced. A female zygote can only be produced when both of the chromosomes in the gamete are 'X'. Chromosome B is X as already said above; now chromosome D is also X. Thus only then when B and D chromosome i.e. X and X chromosome combine, a female zygote is produced.

(iii) The chromosome E is a Y chromosome because when B and E combine a male zygote is produced. B is a X chromosome as discussed above and when E i.e. Y chromosome combine, a male zygote is produced (XY)

(b) Chromosome B and D are of the same type, i.e. X chromosome.

(c) Chromosome E is smaller in size since it is a Y chromosome.

(d) Chromosome B (X) and chromosome E (Y) are known as Sex Chromosomes

(e) (i) C is male since it has half genes from D and half genes from E.

D is a X chromosome and E is a Y chromosome so when they combine a male zygote is formed.

(ii) A is female since it has all B chromosomes in it i.e. X chromosome which is only possible in female.

### 79. Question

Mendel first crossed pure-bred pea plants having round-yellow seeds with pure-bred pea plants having wrinkled-green seeds and found that only round-yellow seeds were produced in the F<sub>1</sub> generation. When F<sub>1</sub> generation pea plants having round-yellow seeds were cross-bred by self-pollination, then peas having round  $\blacklozenge$  yellow seeds, round green seeds, wrinkled-yellow seeds and wrinkled-green seeds were produced. Mendel collected a total of 2160 seeds.

(a) What will be the number of?

(i) Round green seeds

(ii) Wrinkled green seeds

(iii) Round yellow seeds, and

(iv) Wrinkled-yellow seeds

(b) Which 'ratio' as established by Mendel have you made use of in answering the part (a) above?

### Answer

(a) The F<sub>2</sub> generation obtained had Round yellow: Round green: Wrinkled yellow: Wrinkled green in the ratio 9:3:3:1

(i) Round Green seeds-  $(3/16) \times 2160 = 405$

(ii) Wrinkled Green seeds-  $(1/16) \times 2160 = 135$

(iii) Round yellow seeds-  $(9/16) \times 2160 = 1215$

(iv) Wrinkled yellow seeds-  $(3/16) \times 2160 = 405$

(b) Dihybrid ratio has been used in answering this question because here are two different varieties, that differ in two observed traits i.e. Shape : round and wrinkled; Color: yellow and green.

### 80. Question

Pure-bred round-yellow pea seeds have genotype RRY<sub>2</sub> and the pure-bred wrinkled-green pea seeds have genotype rry<sub>2</sub>. Keeping this in mind, write the phenotypes of the following genotypes of hybrid pea seeds:

(a) Rryy

(b) rrYy

(c) rrYY

(d) RrYy

(e) RRyy



**Answer**

- (a) Round-green (RR-round; dominant, yy-green; recessive)
- (b) Wrinkled-yellow (rr-wrinkled; recessive, Yy- since one dominant gene Y is present- yellow)
- (c) Wrinkled-yellow (rr-wrinkled; recessive, YY-yellow, dominant)
- (d) Round-yellow (Rr-one gene dominant R is present-round; Yy- since one dominant gene Y is present- yellow)
- (e) Round-green(RR-round; dominant, yy-green; recessive)

**Very Short Answer Type Questions-Pg-208****1. Question**

What name is given to the sequence of gradual changes over millions of years in which new species are produced?

**Answer**

Evolution is the process of gradual changes in heritable characteristics over long time which leads to the formation of new species. These new species develop from their earlier forms during time.

**2. Question**

Name the scientist who gave the theory of evolution.

**Answer**

Charles Robert Darwin gave the theory of evolution in his book 'Origin of Species' by means of Natural Selection.

**3. Question**

State whether the following statement is true or false: Human beings have evolved from chimpanzees.

**Answer**

The given statement is False. Human beings are more closely related to modern apes but did not evolve from them too. Human beings just share a common ancestor with modern African apes like gorillas and chimps but did not evolve from them.

**4. Question**

State one characteristic which shows that birds are very closely related to dinosaurs.

**Answer**

A feature that is common to both birds and dinosaurs is presence of feathers on their body which shows that birds and dinosaurs are closely related. Dinosaurs had feathers but they could not fly and birds used feathers to provide insulation to their bodies in harsh weather but later on the feathers became useful for flying.

### 5. Question

Name an animal having rudimentary eyes.

#### Answer

Flatworm – *Planaria* has rudimentary eyes as eye spots.

### 6. Question

Name the ancestor of the following: Broccoli, Kohlrabi, Kale.

#### Answer

All the three, Broccoli, Kohlrabi and Kale have a common ancestor that is wild cabbage.

Plant parts of Wild cabbage or *Brassica oleracea* are modified by artificial selection to produce these varieties of cabbage

Flower buds and stem are modified-**Broccoli**

Stem is modified- **Kohlrabi**

Leaves are modified- **Kale**

### 7. Question

Where did life originate on the earth?

#### Answer

It is believed that life originated in sea water, near deep sea hydrothermal vents.

### 8. Question

Write the names of at least three inorganic molecules which helped in the origin of life on the earth.

#### Answer

Methane, Ammonia and Hydrogen Sulphide are the three inorganic molecules that helped in origin of life on earth. Stanley Miller and Harold Urey performed experiments that showed that organic compounds could be synthesized by stimulating conditions of the early earth atmosphere

### 9. Question

Name the famous book written by Charles Robert Darwin.

**Answer**

Charles Robert Darwin wrote the book "Origin of Species" in which he gave theories of Evolution.

**10. Question**

The forelimbs of a frog, a bird and a man show the same basic design (or basic structure) of bones. What name is given to such organs?

**Answer**

Organs that are similar in structures are known as homologous organs because they have basic design of bones but they have different functions. Forelimbs of frog are used to prop up the front ends of the body when at rest, forelimbs of bird are used for flying, and forelimbs of man are used for grasping.

**11. Question**

Name two organisms which are now extinct and studied from their fossils.

**Answer**

Two organisms that are now extinct and studied from their fossils are Dinosaurs and Archaeopteryx lithographica.

Dinosaurs are believed to be ancestors of birds. Archaeopteryx is link between reptiles and birds.

**12. Question**

Out of the wing of a bird, wing of an insect and the wing of a bat:

(a) Which two are homologous organs?

(b) Which two are analogous organs?

**Answer**

(a) Wing of a bird and wing of a bat are homologous organs. They are homologous with their forelimbs which they inherit from common ancestor.

(b) Wing of an insect and wing of a bird are analogous organs. They perform the same function of uplifting the body in air but their basic structure is totally different.

**13. Question**

Why are human beings who look so different from each other in terms of size, color and looks said to belong to the same species

**Answer**

This is because human beings reproduce. There are no geographical barriers so they interbreed easily and produce viable offspring. It is the result of variations that human beings look different from each other in terms of size, color and looks.

#### 14. Question

Name five varieties of vegetables which have been produced from 'wild cabbage' by the process of artificial selection.

#### Answer

Brassica oleracea (wild cabbage) is modified by artificial selection to produce many varieties of vegetables. 5 of such varieties are- Broccoli, Kohlrabi, Kale, Cabbage and Cauliflower.

#### 15. Question

Choose the one term from the following which includes the other three: broccoli, wildcabbage, cauliflower, cabbage.

#### Answer

Various plant parts of Wild Cabbage (Brassica oleracea) are modified by artificial selection to give broccoli, cauliflower and cabbage. Thus, Wild cabbage includes the other three.

#### 16. Question

Fill in the following blanks with suitable words:

- (a) The human forelimb and bat's forelimb are examples of..... organs whereas an insect's wing and a bat's wing are an example of ..... organs.
- (b) The evolution of eye is an example of evolution by .....
- (c) The scientific name of all human beings is.....
- (d) Broccoli has evolved from ..... by the process of artificial selection.
- (e) The theory of natural selection for evolution was proposed by.....

#### Answer

- (a) Homologous organs; Analogous organs.

(Homologous organs are those which have a similar structure; whereas analogous organs are those which have a similar function).

- (b) Stages.

- (c) Homo Sapiens

(Modern specie of humans is Homo Sapiens). Homo sapiens evolved between 250,000 and 100,000 years ago in Africa.

(d) Wild cabbage (*Brassica oleracea*)

(Flower buds and stem are modified traits to produce Kohlrabi)

(e) Charles Robert Darwin.

(Darwin proposed the theory of evolution in his book "Origin Of species", by means of Natural Selection.

### Short Answer Type Questions-Pg-209

#### 17. Question

Match the terms given in column I with those given in column II :

Column I	Column II
(i) Fossil	(a) A famous evolutionist
(ii) A theory of evolution	(b) Survival of the fittest
(iii) Probable ancestor of bird	(c) Petrified remains of prehistoric life
(iv) Charles Darwin	(d) Father of genetics
(v) Gregor Mendel	(e) Archaeopteryx

#### Answer

(i) c – petrified remains of prehistoric life

(Dead remains of animals and plants that petrified under environmental conditions over millions of years)

(ii) b – Survival of the fittest

(Evolution occurs over years by the process of natural selection which is based on survival of the fittest)

(iii) e - Archaeopteryx

(Archaeopteryx is a fossil that had been found and studies revealed that it is a fossil of bird since it had avian features)

(iv) a- a famous evolutionist

Charles Darwin wrote the book "Origin of species"

(v) d- father of genetics

Gregor Mendel is the father of genetics.

### **18. Question**

What is meant by acquired and inherited traits? Explain with one example each.

#### **Answer**

Acquired traits are not inherited by the organism genetically but by environmental conditions present around the organism or the environmental conditions in which the organism lives. For example, Beetles will reduce in weight if not given enough food.

Whereas,

Inherited traits are those characteristics that an organism inherits from his/her parents i.e., passed on genetically through DNA. (Change in DNA). For example –Change of beetles in color from red to green.

### **19. Question**

Why are the traits acquired during the life time of an individual not inherited?

#### **Answer**

A trait can be only inherited when it brings a change in genes present in the gametes of an organism. Changes in non-reproductive tissues cannot be passed on to DNA of germ cells. Therefore traits acquired during lifetime of an individual are not inherited by the offspring because they are changes in somatic cells and not in germ cells.

### **20. Question**

Can the wing of a butterfly and the wing of a bat .be considered homologous organs? Why or why not?

#### **Answer**

No, the wings of a butterfly and the wings of a bat cannot be considered homologous organs because they don't have similar basic structure, even if they perform similar functions i.e. flying. The wings of bat are supported by bones whereas the wing of a butterfly has no bones but is supported by membranous folds which are attached with muscles and not bones. Wings of a butterfly and wings of a bat are analogous organs which have similar functions but different origins.

### **21. Question**

Name two animals having homologous organs and two having analogous organs. Name these organs.

#### **Answer**

Homologous organs are found in humans and lizards. The forelimbs of humans and lizards have different functions completely but the basic structure of bones is similar, i.e. they have same origin. Another example is forelimbs of frog and forelimbs of humans.

Analogous organs are found in bat and butterfly. The wings of a bat and wings of a butterfly have similar function i.e. flying but they have completely different origin.

Another example is wing of an insect and wing of a bird.

### **22. Question**

What are fossils? Giving one example, explain how fossils provide evidence for evolution.

#### **Answer**

Fossils are the dead remains of plants and animals which undergo several physical and chemical processes after they are dead. Example- Archaeopteryx lithographica is a fossil that resembles a bird (has feathers and wings) but has several features of reptiles (tail and teeth). So Archaeopteryx is supposed to be the connecting link between aves and reptiles thus suggesting that birds have evolved from reptiles.

### **23. Question**

Give an example of characteristics being used to determine how close two species are in evolutionary terms.

#### **Answer**

If different organisms have common ancestors then it is possible that they have similar characteristics due to inheritance. These similarities are used to determine their close relations in evolutionary terms. For example - forelimbs of bird and forelimb of humans have similar basic structure of bones which suggests that they have a common ancestor i.e. they are closely related in evolutionary terms. Over time these structures have developed to

function as per the requirement. Thus homologous organs help in determining closeness in evolution.

#### **24. Question**

In what way is homologous organs evidence for evolution?

#### **Answer**

Homologous organs are the organs that have different functions but they are believed to have originated from a common ancestor because of their basic structure of bones. Thus if homologous organs are present in different organisms, it can be inferred that they have same ancestors which provide evidences for evolution.

Example- forelimbs of humans and forelimbs of frog; they have different functions but they have same basic design which tells that they have a common ancestor.

#### **25. Question**

Why are the small numbers of surviving tigers a cause of worry from the point of view of genetics?

#### **Answer**

Small numbers of surviving tigers are a cause of worry from the point of view of genetics because if all the tigers in the world die and become extinct, their genes will be lost forever, they will not come into sight ever again if they become extinct.

#### **26. Question**

Will geographical isolation be a major factor in the speciation of an organism that reproduces asexually?

Give reason for your answer.

#### **Answer**

No; Asexual reproduction is a reproduction wherein an organism does not require another organism to reproduce i.e. there is no fusion of gametes. There is very little variation over generations. Thus, geographical isolation cannot be a major factor in the speciation of an organism that reproduces asexually since variations in DNA are not enough to raise a new species.

#### **27. Question**

Name the various tools of tracing evolutionary relationships which have been used for studying human evolution.

#### **Answer**

- Carbon dating is determination of age by studying relative proportion of carbon isotopes.



- Excavating,-Digging the earth.
- Determining DNA sequences and fossil studies

These are some of the techniques that are being used to study evolution.

### **28. Question**

Out of bacteria, spider, fish and chimpanzee, which organism has a better body design in evolutionary terms? Give reason for your answer.

#### **Answer**

Bacteria has a better body design in evolutionary terms because they can survive hot springs, deep sea and even freezing environment which most of the other organisms cannot.

### **29. Question**

With the help of an example, explain how variation leads to evolution.

#### **Answer**

Large Variations occur when organisms reproduce sexually. Variations refer to changes in the genetic material of a population. Those which are useful for the population and help in survival are selected by process of natural selection. The accumulation of these variations over time leads to the development of new species. Asexual reproduction brings about very less variation and hence it causes no evolution.

For example- animals that reproduce sexually like birds. If birds with long beaks and few birds with short beaks inhabit a new area which has food that can be eaten only with short beaks. Birds with short beaks will have greater survival chances in such an area and hence they will reproduce more, thus increasing their number and evolving.

### **30 A. Question**

What is meant by a species ? Give two examples of plant species and two of animals.

#### **Answer**

(A) A species refers to a group of organisms consisting of similar individuals capable of exchanging genes (interbreeding)

Example

- Plant species- Wheat, Daisies, Conifers, etc.
- Animal species- Cow, Dog, Elephant, etc.

### **30 B. Question**

State the various factors which could lead to the formation of new species.

## **Answer**

(B) Various factors that could lead to formation of new species are Geographical barrier, natural selection and genetic drift.

- Geographical barrier- if sexually reproducing organisms are isolated by geographical barriers then the gene flow through gametes stops and the isolated members interbreed thus leading to the formation of new species.
- Natural Selection- Nature selects individuals that are better adapted to the environment. The organisms that are better adapted survive and reproduce more, whereas the organisms that are not adapted well to the environmental conditions are slowly erased from the environment.
- Genetic drift- genetic drift is changes in the relative frequency of particular genes which leads to disappearance of those genes as individuals either die or they do not reproduce.

### **31. Question**

What evidence do we have for the origin of life from inanimate matter (lifeless matter)?

## **Answer**

The evidence for the origin of life from lifeless matter was given by Stanley Miller and Harold Urey in 1953. They recreated the probable conditions of primitive atmosphere of early earth and demonstrated that simple organic compound like amino acids, hydroxyl acids, sugars and urea can be synthesized in the laboratory from a mixture of methane, hydrogen, water vapour and ammonia. They supplied energy by heating the chamber containing the above mixture to 800 degree C and discharges by electric sparks. After about one week, the liquid was found to contain a number of amino acids such as glycine, alanine and aspartic acid.

### **32. Question**

Does geographical isolation of individuals of a species lead to the formation of a new species? Provide a suitable explanation for your answer.

## **Answer**

Geographical isolation of a species will lead to the formation of a new species if the species reproduces sexually because isolation will stop the gene flow between the isolated populations since they will not be able to reproduce. As a result, the members of isolated populations will interbreed, leading to the formation of new species.

On the other hand if species that reproduce asexually are geographically isolated, there will be no formation of a new species because such species do not need fusion of gametes to reproduce, they reproduce on their own. Hence there will be no formation of a new species.

### **33. Question**

Bacteria have a simpler body plan when compared with human beings. Does it mean that human beings are more evolved than bacteria? Explain your answer.

**Answer**

Since bacteria have a simpler body plan when compared with human being it does not mean that human beings are more evolved. Bacteria do have a simpler body plan but they have ability to survive harsh environmental conditions/ unfavorable habitats such as high temperature, deep sea hydrothermal vents and freezing temperatures as well. Human beings are also well adapted to the environment they live in. Both, bacteria and human beings have evolved differently

**Long Answer Type Questions-Pg-210**

**34 A. Question**

Name the scientist who gave the theory of origin of life on earth. What is this theory?

**Answer**

(A) The theory of origin of life on earth was given by J.B.S Haldane.

The theory states that life developed from simple inorganic molecules (methane, ammonia hydrogen sulphide). Haldane said that the conditions on earth at that time including lightning converted these simple inorganic mol.to complex organic molecules that joined together to form the first primitive life forms.

**34 B. Question**

How are those species which are now 'extinct' studied?

**Answer**

(B) Those species that are now extinct are studied by excavating (digging the earth) and studying their fossils.

**35. Question**

What do you understand by the term 'evolution'? State Darwin's theory of evolution.

**Answer**

Any change in the heritable characteristics of biological population over successive generation is known as Evolution.

Darwin's theory of evolution – Natural Selection

Variation occurs within a population. Although Species produce a great number of offspring yet the population number remains the same. This

constancy in the population number is because of the struggle for resources like food, shelter etc. This is known as struggle for existence. It favors the fit individuals which survive and reproduce and eliminates the unfavorable ones. This is Natural Selection. These variations accumulate together and they form a new species over time

### **36 A. Question**

Explain the terms 'analogous organs' and 'homologous organs' with examples.

#### **Answer**

(A) Analogous organs are organs that are similar in function but have different basic structure which means that they have different origin. For example- Wings of a bird and wings of a bat are analogous organs which have same function of flying but have different basic structure of wings.

Homologous organs are organs that have different functions but have similar basic structure i.e. they have common origin. For example- Forelimbs of man and Forelimbs of frog are similar in structure but they perform completely different functions. Forelimbs of frog are used to prop up at front ends while at rest whereas forelimbs of human are used for grasping.

### **36 B. Question**

In what way is analogous organ evidence for evolution?

#### **Answer**

(B) Analogous organs have similar functions but different origins. Presence of analogous organisms in individuals provides evidence for convergent evolution wherein different organisms with different origins evolve to perform similar functions to adapt to similar environmental niches.

### **37 A. Question**

Define 'speciation'. Explain how speciation occurs.

#### **Answer**

(A) Speciation is the formation of new and different species from existing species in the course of evolution. Speciation occurs when a population gets separated geographically.

### **37 B. Question**

Will geographical isolation be a major factor in the speciation of a self-pollinating plant species? Give reason for your answer.

#### **Answer**

(B) No, geographical isolation will not be a major factor in the speciation of a self-pollinating species because self-pollinating plants do not require any

other plant to reproduce. Hence, No new gene variants will be introduced into the population and thus there will be no evolution of new species.

### **38 A. Question**

Define 'natural selection'.

#### **Answer**

(A) Natural Selection – This theory was given by evolutionist Charles Robert Darwin

Natural selection is a process by which organisms that are better adapted to the environment with their characteristics- survive, reproduce and pass their characteristics to their offspring and organisms that are not adapted well to the environment do not survive much due to the requirements that they fail to accomplish and hence their characteristics are not passed on.

### **38 B. Question**

"Only variations that confer an advantage to an individual organism will survive in a population". Do you agree with this statement? Give reason for your answer.

#### **Answer**

(B) Yes; only variations that confer advantage to an individual organism will survive in a population.

For example- In a population of red beetles, some sudden variation in reproduction produces a green colored beetle. Red beetles are a easy source of prey as they can be easily spotted on the green bushes. The green colored beetle that was produced by a variation could mix up with the green bushes and protect itself from being a prey to predator. If the variation that has occurred in the color of the beetle was blue, then it would have been of no advantage to help in surviving, as it would be easily open to predation like the red beetles.

## **Multiple Choice Questions (MCQs)-Pg-210**

### **39. Question**

In evolutionary terms, we have more in common with:

- A. A Chinese school boy
- B. A chimpanzee
- C. A spider
- D. A bacterium

#### **Answer**

A Chimpanzee is more common in evolutionary terms. Since it's a African ape and human beings and modern African apes have had common ancestors, chimpanzee is more common in evolutionary terms.

#### **40. Question**

The human species has genetic roots in:

- A. America
- B. Africa
- C. Australia
- D. Antarctica

#### **Answer**

Africa

This is because studies show that human and Modern African Ape shared a common ancestor millions of years ago. So, humans are believed to have evolved in Africa.

#### **41. Question**

Which of the following gas was not present in early earth atmosphere?

- A. Ammonia
- B. Oxygen
- C. Hydrogen sulphide
- D. Methane

#### **Answer**

Oxygen

Due to the absence of free oxygen, the organic molecules remain unspoiled and reacted to produce new and more complex organic compounds.

#### **42. Question**

A gradual change, over a long period, in a form of life is known as :

- A. Erosion
- B. Evolution
- C. Revolution
- D. Evaluation

#### **Answer**

## Evolution

Evolution is a phenomenon that brings about continuous and orderly changes in nature. It is a change through time in physical or biological world.

### 43. Question

Scientists believe that all life originated in:

- A. The sea
- B. The soil
- C. The ground
- D. The air

### Answer

The sea

It is believed that life originated about 3.5bya in sea, near deep sea hydrothermal vents.

### 44. Question

According to scientists, aves have evolved from:

- A. Mammals
- B. Amphibians
- C. Reptiles
- D. Arthropods

### Answer

Reptiles

Aves have evolved from reptiles. Archaeopteryx lithographica is a connecting link between reptiles and aves. The fossil bird was of the size of crow and had both reptilian and avian characters.

### 45. Question

The theory of evolution of species by natural selection was given by:

- A. Mendel
- B. Darwin
- C. Dalton
- D. Lamarck

**Answer**

Darwin

Charles Robert Darwin wrote a book 'Origin of Species' in which he gave The theory of Evolution of species by Natural Selection.

**46. Question**

The term 'father of genetics' is used for the scientist:

- A. Morgan
- B. Mendel
- C. Darwin
- D. Marie Curie

**Answer**

Mendel

Gregor Johann Mendel is known as the father of genetics. He worked on Pea plant and discovered the fundamental laws of inheritance.

**47. Question**

One of the following traits cannot be inherited. This one is:

- A. Color of eyes
- B. Color of skin
- C. Size of body
- D. Nature of hair

**Answer**

Size of body

Size of body cannot be inherited because it depends on division capability of somatic cells and physical efforts also. The rest are inherited through gametes.

**48. Question**

Only one of the following characteristic of the parents can be inherited by their children. This one is:

- A. Deep scar on chin
- B. Snub nose
- C. Technique of swimming



D. Cut nose

**Answer**

Snub nose

This is because the rest of them cannot be inherited as they are related to somatic cell characteristics and learning. Only snub nose can be inherited as its trait would be carried in the gene.

**49. Question**

The organs which perform different functions but have the same basic structure are known as:

- A. Homologous organs
- B. Analogous organs
- C. Homolytic organs
- D. Analytic organs

**Answer**

Homologous organs

These organs are similar in their basic structure but they perform different functions. For example- Forelimbs of bird are used for flying, whereas forelimbs of man are used for grasping (i.e. they have same basic structure of bones but perform different functions.)

**50. Question**

The organs which perform similar functions but have different basic structure are called:

- A. Asymmetric organs
- B. Analogous organs
- C. Homologous organs
- D. Homophonic organs

**Answer**

Analogous organs

These organs perform similar functions but have different basic structure. For example- Wing of an insect and wing of a bird perform the same function of uplifting the body in air but their basic structure is totally different.

**51. Question**

Wing of an insect and forelimb of a bird are:

- A. Analogous organs
- B. Analeptic organs
- C. Homologous organs
- D. Homophobic organs

**Answer**

Analogous organs

Wing of an insect and forelimb of a bird help them to lift their body up in the air but their basic structure is totally different, so they are analogous organs.

**52. Question**

If the fossil of an organism is found in the deeper layers of earth, then we can predict that:

- A. The extinction of organism has occurred recently
- B. The extinction of organism has occurred thousands of years ago
- C. The fossil position in the layers of earth is not related to its time of extinction
- D. Time of extinction cannot be determined.

**Answer**

The extinction of organism has occurred thousands of years ago.

Fossils are formed in sedimentary rock which is formed in layers by the deposition and pressure of sediments on top of each other thus the oldest layers are on the bottom, and the youngest layers are on the top.

**53. Question**

Which of the following statement is incorrect with respect to variations?

- A. All variations in a species have equal chance of survival
- B. Change in genetic composition results in variations
- C. Selection of variations by environmental factors forms the basis of evolutionary process
- D. Variations are the minimum in asexual reproduction

**Answer**

All variations in a species have equal chances of survival.

This is incorrect because nature follows survival of the fittest. If variation in a species does not let the organism adapt to surroundings it would not survive for long whereas the species that will be able to adapt to surroundings will survive.

#### **54. Question**

One of the following traits of the parents cannot be passed on to their future generations. This trait is:

- A. Cleft chin
- B. Pointed chin
- C. Scarred chin
- D. Broad chin

#### **Answer**

Scarred chin

This trait cannot be passed from parents to future offspring because chin gets scarred when the somatic cells of the chin are damaged and it is not a trait that is transferred genetically.

#### **55. Question**

Some dinosaurs had feathers although they could not fly but birds have feathers that help them to fly. In the context of evolution, this means that:

- A. Reptiles have evolved from birds
- B. There is no evolutionary connection between reptiles and birds
- C. Feathers are homologous structures in both the organisms
- D. Birds have evolved from reptiles

#### **Answer**

Birds have evolved from reptiles

Reptiles had feathers but could not fly. Over time evolution kept on taking place and with evolution the body size changed and feathers got the ability to help in to flying. Reptiles kept on evolving and their evolution led to the formation of birds which could use feathers for flying. Thus birds have evolved from Reptiles.

#### **56. Question**

Select the incorrect statement from the following:

- A. Frequency of certain genes in a population changes over several generations resulting in evolution

B. Reduction in the weight of an organism due to starvation is genetically controlled

C. Low weight parents can have heavy weight progeny

D. Traits which are not inherited over generations do not cause evolution.

**Answer**

Reduction in the weight of an organism due to starvation is genetically controlled.

This statement is incorrect/false. Reduction in weight due to starvation is a result of less amount of food consumed and is not genetically controlled.

**57. Question**

New species may be formed if:

(i) DNA undergoes significant changes in germ cells

(ii) Chromosome number changes in the gamete

(iii) There is no change in the genetic material

(iv) Mating does not take place

A. (i) and (ii)

B. (i) and (iii)

C. (ii), (iii) and (iv)

D. (i), (ii) and (iii)

**Answer**

New species may be formed if DNA undergoes significant changes in germ cells and Chromosome number changes in the gamete.

If DNA undergoes changes in germ cells that will cause mutations and if chromosome number changes in the gamete it will lead to lethal consequences; both of these changes will lead to formation of new species.

**58. Question**

According to the evolutionary theory, formation of a new species is generally due to:

A. Sudden creation by nature

B. Accumulation of variations over several generations

C. Clones formed during asexual reproduction

D. Movement of individuals from one habitat to another

**Answer**

Accumulation of variations over several generations

Variations when accumulate will lead to natural selection and natural selection is based on survival of the fittest. So, a new species is formed when nature starts selecting species that can survive well.

**59. Question**

The presence of which of the following types of organs in two animals indicates that they are not derived from a common ancestor?

- A. Homologous organs
- B. Excretory organs
- C. Analogous organs
- D. Reproductive organs

**Answer**

Analogous organs

These organs have different origins i.e. they are not derived from common ancestor, but they perform similar functions. For example- Wings of insect and bat.

**60. Question**

The presence of which of the following types of organs in two organisms indicates that they are derived from the same ancestor?

- A. Analogous organs
- B. Respiratory organs
- C. Digestive organs
- D. Homologous organs

**Answer**

Homologous organs

Homologous organs have different functions but they have basic structure of bones which means they have the same ancestor. For example-forelimbs of frog and forelimbs of man. Both have a similar basic structure of bones but forelimbs of frog are used to prop up at front ends when at rest, whereas forelimbs of man are used for grasping.

**61. Question**

One of the following has not been produced from wild cabbage by the process of artificial selection. This one is:

- A. Kohlrabi
- B. Cabbage
- C. Spinach
- D. Kale

**Answer**

Spinach

Kohlrabi, cabbage and kale have been produced from Wild cabbage (Brassica oleracea) by the process of artificial selection.

**62. Question**

The fossil trilobite was originally:

- A. An arthropod
- B. An invertebrate
- C. A reptile
- D. Ave

**Answer**

An arthropod

Trilobite is a fossil group of marine arthropods.

**63. Question**

One pair of organs in the following animals is not homologous. This is:

- A. Forelimbs in humans and lizard
- B. Forelimbs in lizard and frog
- C. Wings in butterfly and bat
- D. Wings in bat and bird

**Answer**

Wings in butterfly and bat

Wings in butterfly and bat are analogous. They have similar functions i.e. flying but they have different ancestors from which they evolved so the pair is not homologous.

#### 64. Question

The wings of a housefly and the wings of a sparrow are an example of:

- A. Analogous organs
- B. Vestigial organs
- C. Respiratory organs
- D. Homologous organs

#### Answer

Analogous organs

Wings of a housefly and wings of a sparrow are analogous organs since they have similar function which is flying but they have evolved independently in each lineage separately after diverging from an ancestor without wing.

### Questions Based on High Order Thinking Skills (HOTS)-Pg-211

#### 65. Question

Some of the important fossils which have been studied are those of organisms X, Y and Z. X were marine arthropods which were common between 400 to 600 million years ago. Y were the invertebrate animals (molluscs) with a flat, coiled, spiral shell which lived in the sea about 180 million years ago. Z are the extinct carnivorous or herbivorous reptiles which appeared on the earth about 250 million years ago and became extinct about 65 million years ago. What are X, Y and Z?

#### Answer

Marine arthropods whose fossils have been studied are known as Trilobites.

Ammonites are the extinct molluscs with flat, coiled spiral shape shell millions of years ago but are now extinct.

Carnivorous animals that appeared about 250mya and disappeared 65 mya are none other than Dinosaurs, as we all know dinosaur disappeared 65mya.

So, X- Trilobites; Y- Ammonites; Z- Dinosaurs.

#### 66. Question

The farmers have been cultivating a food plant X for over two thousand years and have produced as many as five entirely different looking vegetables A, B, C, D and E from it.

(a) What could the plant X be?

(b) What are A, B, C, D and E?

(c) What is the process of evolution involved in this example known as?

## Answer

(a) X- Wild Cabbage (*Brassica oleracea*) is made to produce 5 different varieties of vegetables by artificial selection.

(b) These 5 different looking vegetables are Cabbage, Kohlrabi, Kale, Broccoli, and Cauliflower.

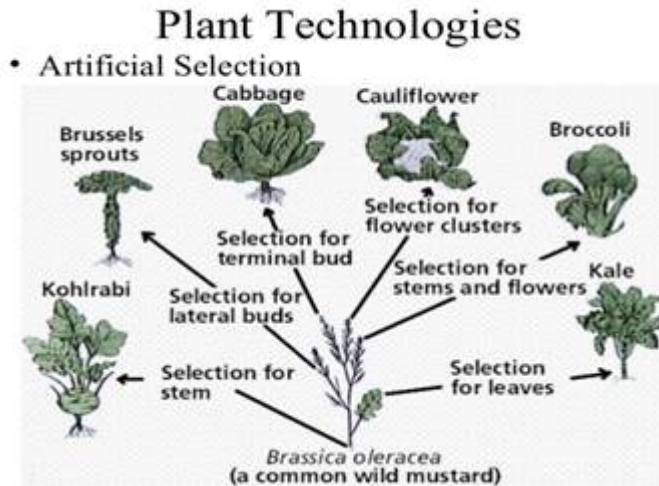

(c) The process of evolution involved in this example is known as Artificial Selection. Artificial Selection is the intentional reproduction of individuals having desired characteristics.

## 67. Question

There are five animals A, B, C, D and E. The animal A uses its modified forelimbs for flying. The animal B uses its forelimbs for running whereas the animal C uses its forelimbs for grasping. The animal D can live on land as well as in water and uses its forelimbs to prop up the front end of its body when at rest. The animal E which respire by using spiracles and tracheae uses wings for flying but its wings are analogous to the modified forelimbs of animal A.

(a) What could the animals A, B, C, D and E be?

(b) Why are the forelimbs of animals A, B, C and D called homologous organs?

(c) What does the existence of homologous organs in animals A, B, C and D tell us about their ancestors?

(d) Why are the modified forelimbs of animal A and the wings of animal E called analogous organs?

(e) State whether animals A and E have a common ancestor or not.

## Answer

(a) Animals A, B, C, D and E could be sparrow, Lizard, human, frog, insect.

(b) Forelimbs of Bird, lizard, human and frog are called homologous organs because their basic structure of bones is similar but they perform different



functions. This means that they have had a common ancestor and with time they adapted themselves according to the requirements.

(c) The existence of homologous organs in animals A, B, C, D tell us that since they have similar basic structure of origin, they have a common ancestor.

(d) Modified forelimbs of Bird and wings of Insect are called analogous organs because they have different basic structure but they perform similar functions. Bird uses its forelimbs to fly; similarly insect uses its wings to fly. Because their basic structure of origin is different so they do not have a common ancestor.

(e) No, Animals having analogous organs do not have a common ancestor because their basic structure of origin is different.

### 68. Question

X, Y, and Z are three animals. The animal X can fly but animal Y can only run on ground or walls. The forelimbs of animals X and Y have the same basic design but they are used for different purposes such as flying and running respectively. The animal Z became extinct a long time ago. The study of fossils of Z tells us that it had some features like those of X and some like those of Y. In fact, Z is said to form a connecting link in the evolutionary chain of X and Y.

(a) What could the animals X, Y and Z be?

(b) What name is given to the forelimbs like those of X and Y which have the same basic design but different functions?

(c) Name one feature in which Z resembled X.

(d) Name one feature in which Z resembled Y.

(e) Which is the correct evolutionary chain involving X, Y and Z:  $X \rightarrow Z \rightarrow Y$  or  $Y \rightarrow Z \rightarrow X$ ?

### Answer

(a) Bird, lizard and dinosaur; Birds can fly ; Lizards can walk on walls; Dinosaurs can fly as well as walk too)

(b) Homologous organs. (Organs that have same structure but different function)

(c) Feathered Wings as in birds

(d) Tail as in reptiles

(e)  $Y \rightarrow Z \rightarrow X$ ?

### 69. Question

A population of red beetles lives in green bushes in a garden. Once during the process of breeding, a green beetle is produced.

- (a) State whether the change in color of beetle is a process of evolution or not.
- (b) Can the new color of green beetle be passed on to its next generations?
- (c) What will be the advantage (if any) of the green color to the beetle?
- (d) State whether the production of green color involved a change in genetic material or not.

### **Answer**

- (a) Yes; the change in color of beetle is a process of evolution which might have occurred to adapt to certain environmental condition.
- (b) Yes; the color of green beetles can be passed on to the next generation through genes.
- (c) The green color will protect the beetle from predation as it will help the beetle hide in the bushes.
- (d) Yes; it involved a change in genetic material because unless and until the gene responsible for color gets some changes, no new color can be produced than the original one.

### **70. Question**

The organs P and Q of two animals have different structures but similar functions. On the other hand, the two organs R and S of two other animals have the same basic structure but different functions.

- (a) What are the organs like P and Q known as?
- (b) Name the organs like P and Q. Also name the animals which have such organs.
- (c) What are the organs like R and S called?
- (d) Name the organs like R and S. Also name the animals which have such organs.

### **Answer**

- (a) These organs that have different basic structure but perform similar functions are known as analogous organs. So organs P and Q are analogous organs.
- (b) Wings of a Butterfly and wings of a sparrow; wing of an insect and wing of a bird.
- (c) These organs that have similar basic structure but perform different functions are known as homologous organs. So organs R and S are homologous organs
- (d) Forelimbs; Forelimbs of a frog and forelimbs of human are homologous.

