

EXPERIMENT 5

AIM

To determine the internal resistance of a given primary cell using a potentiometer.

APPARATUS AND MATERIAL REQUIRED

Potentiometer, Leclanche cell or dry cell, an ammeter, one resistance box (R_{BOX_1}) (about 0-50 Ω), 3 one way plug keys, galvanometer, a high resistance box (R_{BOX_2}) (about 0-10 k Ω), a low resistance rheostat of about 20 Ω , jockey, lead accumulator and connecting wires.

PRINCIPLE

When a resistance R is connected across a cell of emf E and internal resistance r , then the current I in the circuit is

$$I = \frac{E}{R + r} \quad \text{[E 5.1]}$$

The potential difference $V (= RI)$ across the two terminals of the cell is

$$V = \frac{E}{R + r} R \quad \text{[E 5.2]}$$

Thus
$$\frac{E}{V} = 1 + \frac{r}{R}$$

or
$$r = \left(\frac{E}{V} - 1 \right) R \quad \text{[E 5.3]}$$

If l_0 and l are the distances of the balance null point from end A of the potentiometer for an open and a closed circuit respectively (Fig. E 5.1), then E is proportional to l_0 and V is proportional to l .

$$\frac{E}{V} = \frac{l_0}{l} \quad \text{[E 5.4]}$$

From Eqs. (E 5.3) and (E 5.4)

$$(E\ 5.5) \quad r = \left(\frac{l_0 - l}{l} \right) R$$

PROCEDURE

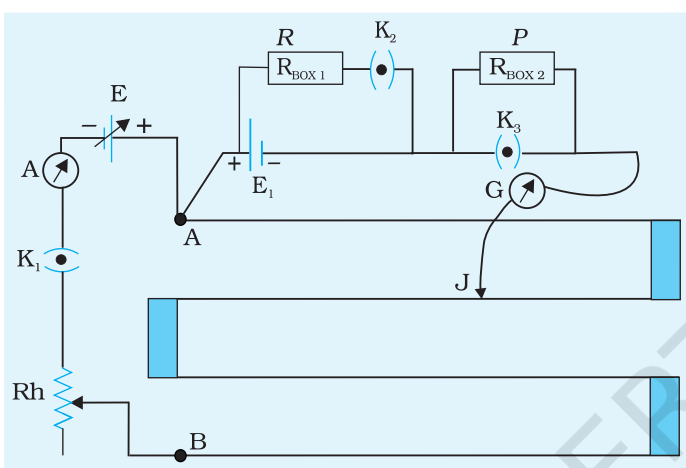

Fig. E 5.1 Circuit to measure internal resistance of a primary cell using a potentiometer

1. Connect different electrical components as shown in the circuit (Fig. E 5.1). After checking the circuit connections, close key K_1 .
2. With keys K_2 and K_3 open and a protective high resistance P from the $R_{\text{BOX}2}$, find the position of the balance point. For final reading, short circuit the resistance P by closing the key K_3 and find the balance length l_0 .
3. Take $R = 10\ \Omega$ (from $R_{\text{BOX}1}$), close the key K_2 and quickly measure the new balance length l . Open K_2 as soon as this has been done.
4. Keep the readings in the ammeter constant throughout the above observation.
5. Reduce the value of R in equal steps of $1\ \Omega$ and for each value of R obtain the balance length l .
6. At the end of the experiment, open key K_2 and repeat step 2 to find l_0 again.

OBSERVATIONS

$l_0 = \dots$ cm (in the beginning of the experiment)

$l_0 = \dots$ cm (at the end of the experiment)

Mean $l_0 = \dots$ cm.

Table E 5.1: Balance length

Sl. No.	$R\ \Omega$	$l\ \text{cm}$	$\frac{1}{R}\ \Omega^{-1}$	$\frac{1}{l}\ \text{cm}^{-1}$	$r = \left(\frac{l_0 - l}{l} \right) R\ \Omega$
1					
2					
--					
6					

CALCULATIONS

1. Substitute the value of l_0 , l and corresponding value of R in

$$\text{Eq. (E 5.5) and calculate the value of } r, \text{ where } r = \frac{l_0 - l}{l} R.$$

2. Use graphical method also to obtain r . Note that Eq (E 5.5) can be written as

$$\frac{1}{R} = \frac{l_0}{r} \left(\frac{1}{l} \right) - \frac{1}{r} \quad \text{(E 5.6)}$$

It is an equation of a straight line (Fig. E 5.2).

3. Plot a graph between $1/R$ and $1/l$, taking

$$\frac{1}{l} \text{ on the x-axis and } \frac{1}{R} \text{ on y-axis.}$$

4. Draw a straight line as close to the points plotted as you can. The negative intercept on the y-axis gives the value of $1/r$. Hence, obtain the value of r (Fig. E 5.2).

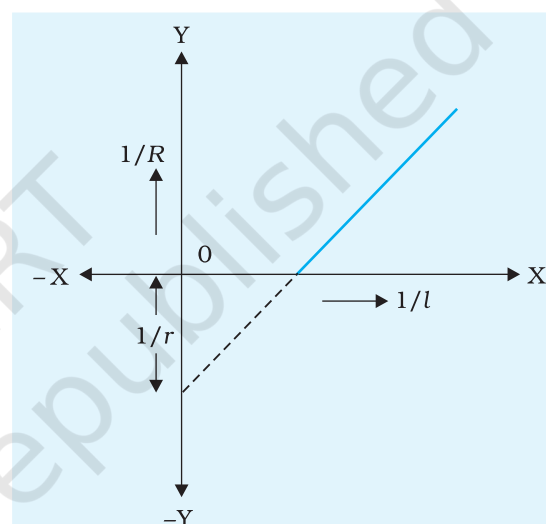

Fig. E 5.2 Graph between $1/R$ and $1/l$

RESULT

The internal resistance of the given cell r

- (i) by calculation ... Ω
- (ii) by graph ... Ω

PRECAUTIONS

1. The primary cell whose internal resistance is to be determined should not be disturbed during the experiment or else its internal resistance may change.
2. The emf of battery E should be more than the emf of the primary cell, E_1 .
3. Positive terminals of E and E_1 both should be connected at the same point on the potentiometer.
4. Always measure length from point A i.e. the point at which positive terminals of battery are connected and measure this length upto the balance point.

5. Insert K_1 and K_2 only when readings are taken otherwise the wires may get heated up due to continuous flow of current and may also affect the internal resistance of the cell.

SOURCES OF ERROR

1. Potentiometer wire may not be of uniform cross - section.
2. Brass strips at the ends may have a finite resistance.
3. Emf of the auxiliary battery producing the drop of potential along the wire may not be constant throughout the course of the experiment.
4. Heating of the potentiometer wire by current may introduce some error.

DISCUSSION

1. The theory of potentiometer assumes that there is a steady current in wire AB during the period of experiment. Therefore, emf of the accumulator should be constant during the course of the experiment.
2. The position of the jockey can be read within the least count of the measuring scale $\pm 0.1\text{cm}$. Moreover, the edge of the jockey may further limit this least count. It is therefore advised to use a sharp edged jockey.
3. There may also be a zero error in the measurement of l , due to the end of the scale not being exactly at the end of the wire.

SELF ASSESSMENT

1. All the positive terminals of sources of emf are joined at point A of potentiometer, but if all the negative terminals of sources of emf are joined at point A then how will the balance length be affected?
2. Find the internal resistance of a freshly prepared Leclanche cell. Does its internal resistance change with R ?
3. State the factors on which the internal resistance of a cell depends.

SUGGESTED ADDITIONAL EXPERIMENTS/ACTIVITIES

1. Find the internal resistance of dry cells of different makes.
2. Can the internal resistance of a secondary cell be determined by this method? Give reason for your answer.