

## AIM

To determine the wavelength of a laser beam by diffraction.

## APPARATUS AND MATERIAL REQUIRED

A He-Ne or semiconductor laser, a shining steel scale with mm graduations, one metre scale, clamp stand, a graph paper sheet mounted on a card board.

## TERMS AND DEFINITIONS

**Laser:** Light Amplification by Stimulated Emission of Radiation (abbreviated as LASER).

**Diffraction:** The phenomenon of bending of light from narrow holes or slits.

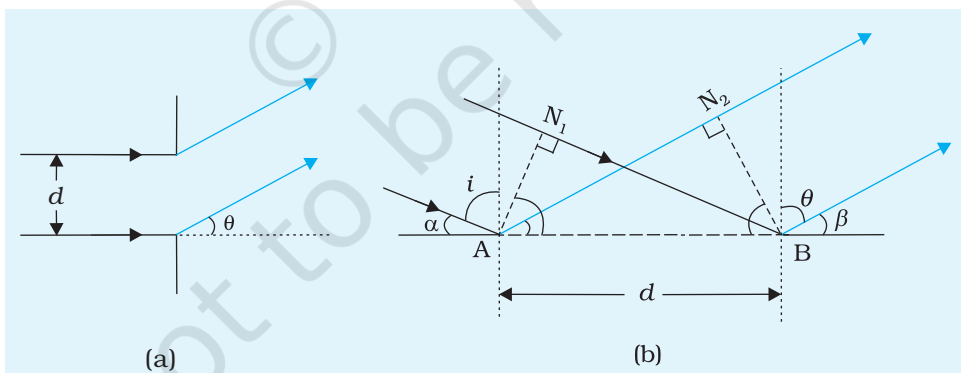

**Fig. P 1.1** Single slit diffraction (a) normal incidence (b) oblique incidence

## PRINCIPLE

If a parallel beam of light of wavelength  $\lambda$  falls normally on a single slit of width  $d$  (as shown in Fig. P 1.1(a)) the central maximum of the diffraction pattern occurs at  $\theta = 0$  and subsequent maxima appear at

$$\sin\theta = n + \frac{1}{2} \frac{\lambda}{d}, \quad n \neq 0$$

Consider now, many such “slits” equally spaced as in a shiny steel scale. Also the angle of incidence of the light beam may be close to 90°.

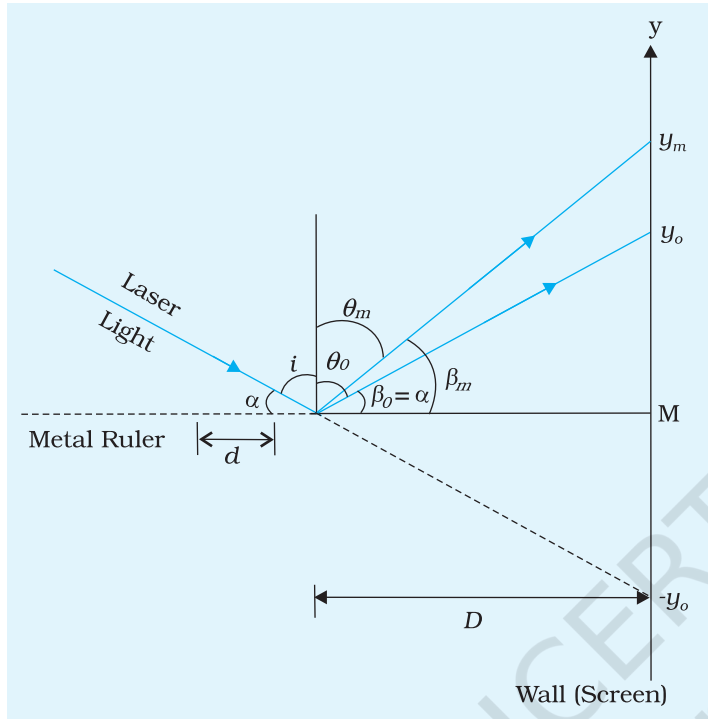

**Fig. P 1.2** Schematic diagram of the experimental arrangement

Referring to Fig. P1.1(b), the path difference between the incident and diffracted beam is

$$(N_1B - AN_2) = d(\sin i - \sin \theta)$$

$i$  is Angle between the incident ray and the perpendicular.

If the engravings on a metal scale are used for diffraction of light of wavelength  $\lambda$  incident at an angle of incidence  $i \leq 90^\circ$ , for the  $m^{\text{th}}$  order maximum, diffracted at an angle  $\theta_m$  as shown in Fig. P1.2, we have

$$d(\sin i - \sin \theta_m) = m\lambda$$

where the spacing  $d$  between successive engravings is constant.

If  $d = 1\text{mm}$

$\alpha =$  Angle between incident ray and the steel scale

$$\alpha = \left(\frac{\pi}{2} - i\right) \text{ and } \beta_m = \left(\frac{\pi}{2} - \theta_m\right)$$

The above equation can be written as

$$d(\cos \alpha - \cos \beta_m) = m\lambda$$

For the zeroth order ( $m = 0$ ), the beam is peculiarly reflected and  $\alpha = \beta_0$ .

Let  $D$  be the distance between the region of incidence at the scale and the screen. The diffraction spots lie along the  $y$ -axis, and the position of the  $m^{\text{th}}$  spot is represented by  $y_m$ .

From Fig. P1.2

$$\cos \beta_m = \frac{D}{\sqrt{D^2 + y_m^2}} = \frac{D}{D\sqrt{1 + \frac{y_m^2}{D^2}}}$$

$$\cos \beta_m = \left[1 + \left(\frac{y_m}{D}\right)^2\right]^{-1/2}$$

(P 1.1)

$$= 1 - \frac{1}{2} \frac{y_m^2}{D^2} + \dots$$

Using binomial expansion ( $\because y_m \ll D$  for all  $m$ )

$$\text{and } \cos \alpha = \cos \beta_0 = 1 - \frac{1}{2} \frac{y_0^2}{D^2} + \dots$$

$$\therefore \cos \alpha - \cos \beta_m \approx (y_m^2 - y_0^2) / 2D^2 = \frac{m\lambda}{d} \text{ from Eq. (P1.1)}$$

Thus, wavelength of the light is given by

$$\lambda = d(y_m^2 - y_0^2) / 2mD^2.$$

## PROCEDURE

1. Clamp the metal scale in the horizontal position on a stand.
2. Clamp the laser source on another stand, near the edge of the scale.
3. Place both stands on the table keeping the distance between them about 20 cm, also both should be at the same height.
4. Fix a graph sheet on a wall facing the laser source and at a distance of 3-4 m from the scale.
5. Turn on the laser source and incline the same such that the laser beam strikes the grooves on the scale at a grazing angle such that diffraction spots are observed on the graph.  
(You may need to adjust the position and orientation of the scale and the source to observe the spots on the graph sheet).
6. Now keep the position and orientation of laser and the scale fixed.
7. Mark position of various diffraction spots on the graph paper.
8. Remove metal scale and observe the spot directly coming from the laser source on the graph paper. Mark this position as  $(-y_0)$ .
9. Find the mid point of direct beam position  $(-y_0)$  and first spot  $(y_0)$  on the graph and mark it as M.
10. Now measure the distance of the second spot  $(y_1)$  from M.
11. Repeat steps 7 to 10 for obtaining readings for 2nd and 3rd order of diffraction pattern.

## OBSERVATIONS

*For First Order*

$d = 1\text{mm}$

$D = \dots \text{m}$

Distance of 1st spot from M( $y_0$ ) = ... $y_0$

Distance of 2nd spot from M( $y_1$ ) = ... $y_1$

*Observations for 2nd and 3rd order - Same as for 1st order.*

## CALCULATIONS

Calculate the value of  $(y_1^2 - y_0^2)$  for each set and then find the average value of  $(y_1^2 - y_0^2)$

Use the average value in the formula

$$\lambda = \frac{d(y_1^2 - y_0^2)}{2D^2}$$

Find the value of  $\lambda$ .

## RESULT

Wavelength of laser beam = ... m

## DISCUSSION

1. While considering from obstacles of the order of 1mm, why is it necessary to consider grazing incidence of the visible light?

Can diffraction be observed when  $i = 45^\circ$ ?

2. Lattice constant of a sodium crystal is  $1\text{\AA}$ . Can you obtain diffraction of a laser light from a sodium crystal?

**SUGGESTED ADDITIONAL EXPERIMENTS/ACTIVITIES**

Using the same principle as in this project, measure the width of a pencil by placing a bunch of them adjacent to each other as shown in Fig. P 1.3 below.

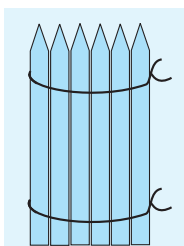

**Fig. P 1.3** A bunch of pencils placed touching each other

# PROJECT 2

## AIM

To study various factors on which the internal resistance of a cell depends.

## APPARATUS AND MATERIAL REQUIRED

Potentiometer, battery, three one way keys, a rheostat of low resistance, a galvanometer, a high resistance box, a fractional resistance box, an ammeter, a voltmeter, a voltaic cell, electrolytes of different concentrations, a jockey, connecting wires and sand paper.

## TERMS AND DEFINITIONS

1. *Internal resistance*: The resistance offered by the electrolyte of a cell to the flow of current through it.
2. *EMF (E)*: Potential difference of a cell in an open circuit i.e., when no current is drawn from it.

## PRINCIPLE

*Principle of a potentiometer*: Potential difference across the length of a conductor of uniform area of cross-section carrying steady current is directly proportional to its length.

The internal resistance of a cell depends on

- (i) distance between the plates (electrodes)
- (ii) common area of the electrodes immersed in the electrolyte and
- (iii) concentration of the electrolyte.

## PROCEDURE

1. Prepare a cell filled with an electrolyte of given concentration (Fig. P 2.2).

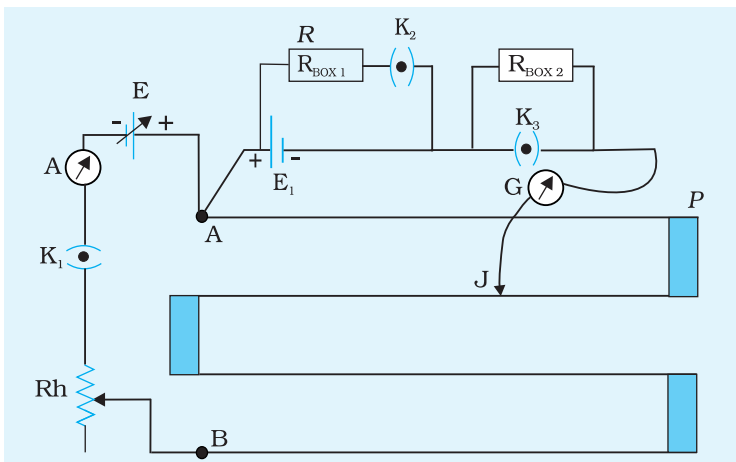

**Fig. P 2.1** Circuit to measure internal resistance of a primary cell using potentiometer

**Fig. P 2.2** Voltaic cell with an electrolyte of given concentration

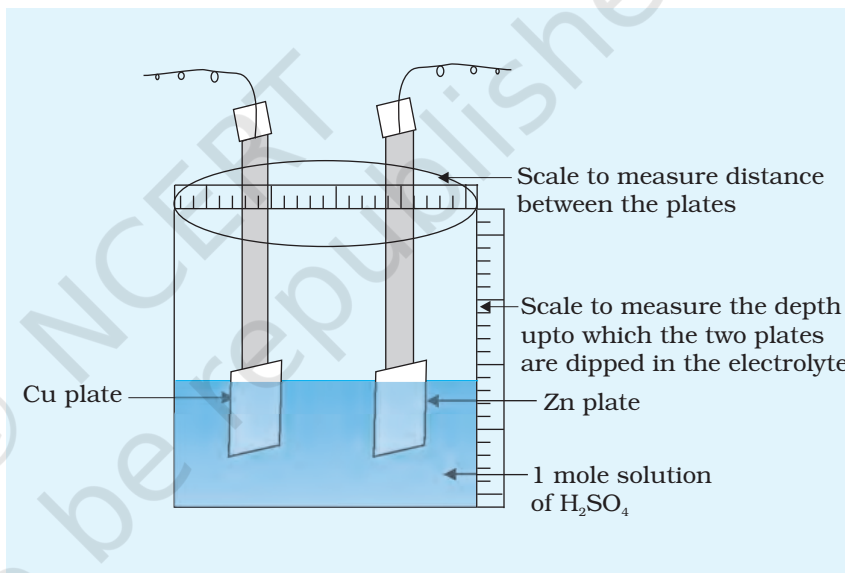

2. Arrange the circuit, as done for the determination of internal resistance of a cell (Fig. P 2.1) (Refer Experiment E 5).
3. Determine the internal resistance of the given cell as described in Experiment E 5.

## OBSERVATIONS AND CALCULATIONS

### I. Effect of separation between the plates

Determine the internal resistance of the cell for different separations between the plates with the same electrolyte. Keep the common area of the plates immersed in electrolyte same throughout your observation. Record the observations in Table P 2.1.

**Table P 2.1: Dependence of internal resistance on separation between the plates**

Sl. No.	Separation between plates (cm)	R ( $\Omega$ )	Balancing length (cm)		Internal Resistance $r = R \times \left( \frac{l_0 - l}{l} \right)$ ( $\Omega$ )
			Open circuit (when keys $K_2$ and $K_3$ are open)  length $l_0$ (cm)	Closed circuit (when keys $K_2$ and $K_3$ are closed)  length $l$ (cm)	
1					
2					
3					

**II. Effect of common area of plates immersed in electrolyte**

Determine the internal resistance of the cell by changing the depth upto which the two plates are immersed in the electrolyte or by changing the level of electrolyte in the cell. Record the observations in Table P 2.2.

Breadth of plate : ... cm.

**Table P 2.2: Dependence of internal resistance on common area of plates immersed in electrolyte**

Sl. No.	Length of the plate immersed in the electrolyte (cm)	R ( $\Omega$ )	Balancing length (cm)		Internal Resistance $r = R \times \left( \frac{l_0 - l}{l} \right)$ ( $\Omega$ )
			Open circuit (when keys $K_2$ and $K_3$ are open)  length $l_0$ (cm)	Closed circuit (when keys $K_2$ and $K_3$ are closed)  length $l$ (cm)	
1					
2					
3					

**III. Effect of concentration of the electrolyte**

Maintain a constant distance between the two plates and keep their area immersed in the electrolyte same. Determine the internal resistance of the cell by filling it with electrolyte of given concentration. Repeat this measurement with electrolytes of varying concentrations, but filling the cell upto the same level in every case. Record the observations in Table P 2.3.

**Table P 2.3: Dependence of internal resistance on the concentration of the electrolyte**

Sl. No.	Concentration of the electrolyte (in moles)	R ( $\Omega$ )	Balancing length (cm)		Internal resistance $r = R \times \left( \frac{l_0 - l}{l} \right)$ ( $\Omega$ )
			Open circuit (when keys $K_2$ and $K_3$ are open) length $l_0$ (cm)	Closed circuit (when keys $K_2$ and $K_3$ are closed) length $l$ (cm)	
1					
2					
3					

**R**ESULT

- Internal resistance of a cell increases with increase in distance between the electrodes.
- Internal resistance increases with decrease in common area of electrodes immersed in the electrolyte.
- Internal resistance increases with decrease in concentration of the electrolyte.

**P**RECAUTIONS

- Ensure that the emf of battery E is greater than emf of cell  $E_1$ .
- Positive terminals of E and  $E_1$  both should be connected at terminal A of the potentiometer.
- The current should not be passed for a long time so as to avoid any heating of the wires resulting in the change of resistance.



4. The length of the wire should always be measured from the end A of the wire, where all the positive terminals are connected.
5. Jockey should not be pressed too hard on the wire, otherwise the diameter of the wire may not remain uniform. Also do not press the jockey on the wire while sliding it.

## SOURCES OF ERROR

1. Potentiometer wire may not be of uniform area of cross-section throughout its entire length.
2. The emf of the auxiliary battery producing the fall of potential along the potentiometer may not be constant throughout the course of experiment.
3. End resistance of potentiometer wire are not taken into account.
4. Heating of the potentiometer wire due to current, may introduce some error.

## DISCUSSION

1. Internal resistance of a cell also depends upon temperature. Temperature of the electrolyte should therefore be kept constant throughout.
2. In order to protect the galvanometer from damage due to excessive current, a high resistance should be connected in series with it while obtaining approximate position of the balance point. This does not affect the position of the balance point in any way. However, this resistance should be removed while trying for the exact position of the balance point. The same purpose can be achieved by using a shunt across the galvanometer.
3. Internal resistance also depends upon the current drawn, so the current drawn should not change appreciably.
4. The resistance of a conductor increases with its length, hence the internal resistance of a cell increases with separation between the plates.
5. The resistance of a conductor varies inversely with its area of cross-section. Hence, the internal resistance of a cell increases with decreasing common area between the plates.
6. The conductivity of an electrolyte depends on the degree of dissociation of the electrolyte.

## SELF ASSESSMENT

---

1. What inference would you draw on getting deflection in the galvanometer in one direction only?
2. Can  $R$ , the external resistance across the cell be varied over a large range?
3. How can the sensitivity of the potentiometer be increased?
4. You are given two cells A and B. Cell A is freshly prepared and cell B has been in use for some time. Which of the two has less internal resistance?

© NCERT  
not to be republished

# PROJECT 3

## A<sub>IM</sub>

To construct a time switch and study the dependence of its time constant on various factors.

## A<sub>PPARATUS AND MATERIAL REQUIRED</sub>

A battery (6 V), a bulb (6 V, 0.06 A), a relay (magnetic - 185  $\Omega$ ), a transistor (n-p-n BC 108), two switches  $S_1$  and  $S_2$ , resistors of  $\frac{1}{2}$  W each (5 k  $\Omega$ , 10 k  $\Omega$ , 15 k  $\Omega$ ), capacitors (electrolytic type, 500  $\mu$ F, 1000  $\mu$ F, 2000  $\mu$ F), connecting wires and a stop watch.

## P<sub>RINCIPLE</sub>

When a capacitor of capacitance  $C$  is allowed to get charged through a resistance  $R$ , then the charge acquired by the capacitor at any instant of time is given by  $q(t) = q_0 [1 - e^{-t/\tau}]$  where  $\tau = RC$  is the time constant.

The time constant of a circuit is defined as the time taken by the capacitor to acquire 63.7 per cent of the maximum charge while charging.

## P<sub>ROCEDURE</sub>

1. Arrange the components and make the circuit as shown in Fig. P 3.1.
2. Close the switch  $S_1$  and start the stop watch. The lamp  $L$  is switched ON and the capacitor  $C$  starts getting charged through the resistance  $R$ .
3. After sometime, the voltage across the capacitor would exceed a threshold value so that a base current begins to flow through the transistor  $T$  and hence a collector current also flows. This breaks the relay contacts and the bulb goes OFF. Now stop the stopwatch as soon as the lamp goes OFF. Note the time interval and compare it with the product of  $R$  and  $C$ .
4. Use three values of  $C$  e.g. 500  $\mu$ F, 1000  $\mu$ F, 2000  $\mu$ F keeping the value of  $R$  (say 5 k $\Omega$ ) fixed and measure time interval in every

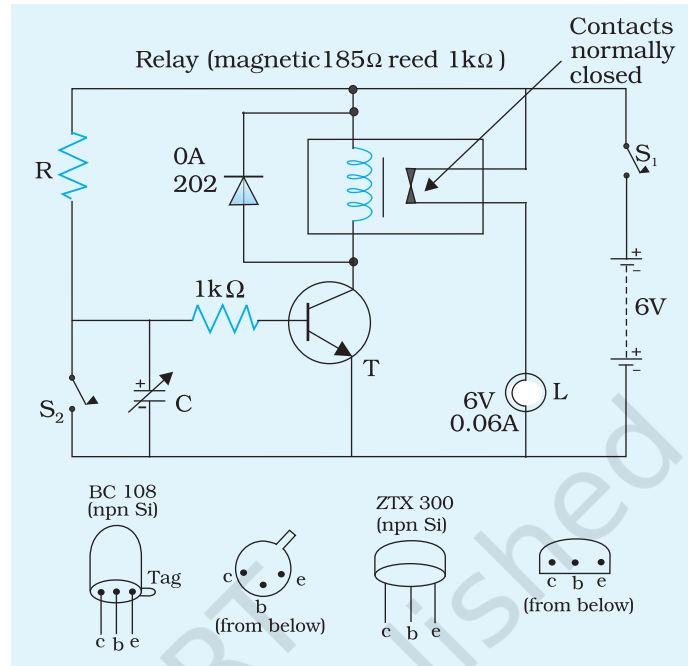

**Fig. P 3.1** Circuit of a time switch

case. Repeat the procedure by keeping  $R = 10\text{ k}\Omega$  and  $15\text{ k}\Omega$ . Record the observations in Table P 3.1.

- Use three values of  $R$  (e.g.  $5\text{ k}\Omega$ ,  $10\text{ k}\Omega$ , and  $15\text{ k}\Omega$ ), keeping the value of  $C$  fixed (say  $c = 500\mu\text{f}$ ) and again measure the time interval between ON and OFF. Repeat the procedure by capacitors of  $C = 1000\mu\text{f}$  and  $2000\mu\text{f}$ . Record observations in Table P 3.2.

## OBSERVATIONS AND CALCULATIONS

Least count of stop watch = ... s

**Table P 3.1: Time interval when  $R$  is constant**

S 1 No.	$R_1 = 5\text{ k}\Omega$		Product RC (s)	$R_2 = 10\text{ k}\Omega$		Product RC (s)	$R_3 = 15\text{ k}\Omega$		Product RC (s)
	Value of $C (\mu\text{F})$	Time interval (s)		Value of $C (\mu\text{F})$	Time interval (s)		Value of $C (\mu\text{F})$	Time interval (s)	
1									
2									
3									

**Table P 3.2: Time interval when C is constant**

Sl. No.	$C_1 = 500 \mu\text{F}$		Product $RC$ (s)	$C_2 = 1000 \mu\text{F}$		Product $RC$ (s)	$C_3 = 2000 \mu\text{F}$		Product $RC$ (s)
	Value of $R$ ( $k\Omega$ )	Time interval (s)		Value of $R$ ( $k\Omega$ )	Time interval (s)		Value of $R$ ( $k\Omega$ )	Time interval (s)	
1									
2									
3									

## RESULT

Time operated switch is ready and the product  $RC$  is the time constant.

## PRECAUTION

Check carefully the circuit and various components connected to it. Take special care to avoid any dry soldering.

## SELF ASSESSMENT

If instead of n-p-n transistor, a p-n-p transistor is used in the given circuit, how will you change the circuit?

### SUGGESTED ADDITIONAL EXPERIMENTS/ACTIVITIES

A capacitor can be connected in parallel with the load in a full wave rectifier to smoothen the pulsating dc obtained from it. Relate the charging and discharging of the capacitor to this smoothening action of the capacitor filter. Also discuss, will the smoothening improve if a capacitor of larger capacitance is used.

# PROJECT 4

## AIM

To study infrared radiations emitted by different sources using phototransistor.

## APPARATUS AND MATERIAL REQUIRED

A phototransistor, milliammeter (0 – 30mA), two 6 V batteries, infrared sources such as an IR LED, incandescent lamps (40 W, 60 W, 100 W), variable resistance, resistors (1k $\Omega$  5 k $\Omega$ ), Keys, connecting wires.

## DESCRIPTION OF APPARATUS/DEVICES

*Phototransistor* : A photodetection device in which an electric current is obtained at the collector when light falls on its base region.

A tungsten incandescent lamp (domestic light bulb) is also a source of both visible and *infrared radiations*.

## TERM AND DEFINITION

Electromagnetic radiations in the frequency range of  $10^{11}$  Hz to  $10^{14}$  Hz are called *infrared radiations* since their wavelength is greater than that of the visible red.

## PRINCIPLE

The magnitude of the current in the collector circuit depends on the intensity of the incident radiation falling on the base region.

## PROCEDURE

As the photodetector is a sensitive device, house the source and the detector in a closed box so that stray radiations (visible/IR) are totally cut off. Moreover, you should be able to change the separation between the source and the detector and also measure the separations as well, without changing their relative orientation. The entire assembly of the devices is as shown in Fig. P 4.1.

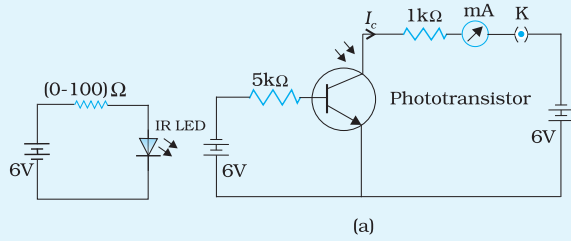

(a)

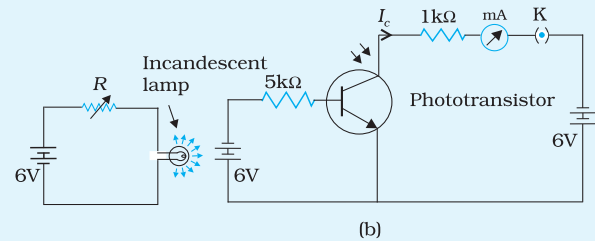

(b)

**Fig. P 4.1 (a)** Circuit to measure IR radiation from IR LED using phototransistor

**Fig. P 4.1 (b)** Circuit to measure IR radiation from incandescent lamp using phototransistor

First maximise the current in the IR detector by placing the IR LED/ incandescent lamp close to the detector. Measure this distance. Note down the ammeter reading. Now increase this distance in steps and note down the corresponding ammeter reading and record your observations in tabular form.

Repeat your observations for different sources (incandescent lamps).

## OBSERVATIONS

Range of the milliammeter = ...mA

Least count of the milliammeter = ...mA

Initial reading of the milliammeter = ...mA

**Table P 4.1: Detector current for different sources**

Sl. No.	Source	Power input	Position of detector w.r.t. the source $x$ (cm)	Detector current $I$ (mA)
1	IR LED	small	(i)	
			(ii)	
			(iii)	
			(iv)	
2	Bulb	40 W	(i)	
			(ii)	
			(iii)	
			(iv)	
3	Bulb	60 W	(i)	
			(ii)	
			(iii)	
			(iv)	
4	Bulb	100 W	(i)	
			(ii)	
			(iii)	
			(iv)	

## RESULT

---

1. Detector current changes with increase in distance of the detector from the source.
2. For same distances, detector current is different for different sources.

## PRECAUTIONS

---

1. Connections should be neat and tight.
2. Source and detector should be enclosed in a closed box so that stray radiations are cut off.

## SOURCES OF ERROR

---

1. Stray radiations may not be cut off completely.
2. Least count of milliammeter may cause an error.

## DISCUSSION

---

1. In the circuit shown in Fig. P 4.1 there is a provision to change IR LED current. Do you think it will affect the intensity of emitted radiation or the frequency of radiation or both? Try the same setup using red, yellow and green LEDs instead of the IR LED.
2. The detector material is sensitive to IR. What do you think would be the value of its work function?
3. If you repeat this experiment with the same detector, but with a microwave source, do you think there will be any detector current?

### SUGGESTED ADDITIONAL EXPERIMENTS/ACTIVITIES

---

1. One can use the above set up to study the effect of frequency of light sources on the detector current, by using different coloured filters. We can use red, orange, yellow, green, blue filters and show how detector gives no current for red and orange light, but gives current for green and blue filters.
2. Draw the detector position ( $x$ ) versus detector current ( $I$ ) graph for each set of observations.



# PROJECT 5

## A<sub>IM</sub>

To design an automatic traffic signal system using suitable combination of logic gates.

## A<sub>PPARATUS AND MATERIAL REQUIRED</sub>

LEDs (of red, yellow, green colours) four each, one IC 555 timer, one IC 7490, two NOT gates (or a single IC 7400), four NAND gates (or single IC 7400), capacitors of 0.1  $\mu\text{F}$ , 10 $\mu\text{F}$  (16 V), resistors of 5.6 k  $\Omega$ , 150 k  $\Omega$  (1 W) each, four resistors of 220 k  $\Omega$  (1 W) each, two resistors of 47 k  $\Omega$  (1 W) each, battery, switch.

## P<sub>RINCIPLE</sub>

Integrated circuit (IC) is an extremely small sized electronic circuit which incorporates a whole system of electronic components and devices. Depending on the number of components fabricated on a chip, the integrated circuits are classified into various classes; 555 timer, IC 7400 etc. are examples of MSI (Medium Scale Integrated) circuits. Any logic gate operation can be achieved by using suitable IC's.

The basic arrangement of traffic light system which is used at a common road-crossing is shown in Fig. P 5.1.

Each traffic light system uses red, yellow and green lights. These days LEDs are used for this purpose (represented here by  $R_1, Y_1, G_1; R_2, Y_2, G_2; R_3, Y_3, G_3$  and  $R_4, Y_4, G_4$ ). In traffic light system, usually the lights of the same colour on the opposite sides of the cross roads are either ON or OFF simultaneously, so the LED pairs  $R_1$  and

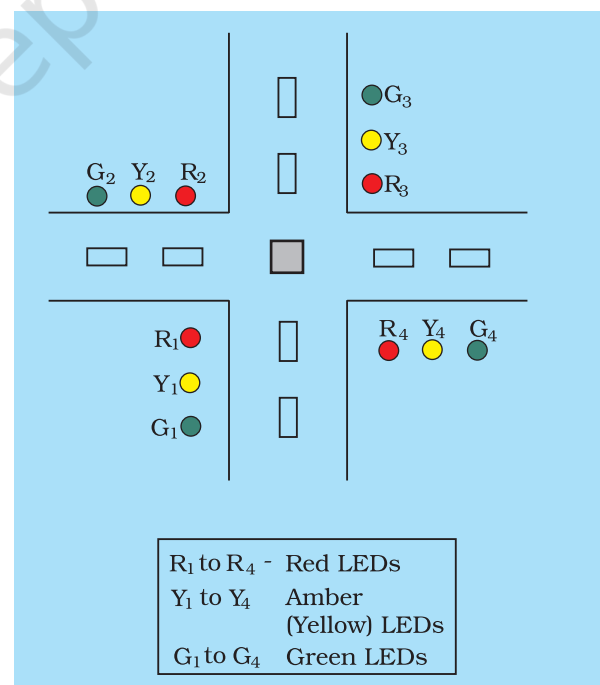

**Fig. P 5.1** Schematic diagram of basic road traffic light system

$R_3, R_2$  and  $R_4, Y_1$  and  $Y_3, Y_2$  and  $Y_4, G_1$  and  $G_3$  and  $G_2$  and  $G_4$  are connected in series. This arrangement is shown in Fig. P 5.2.

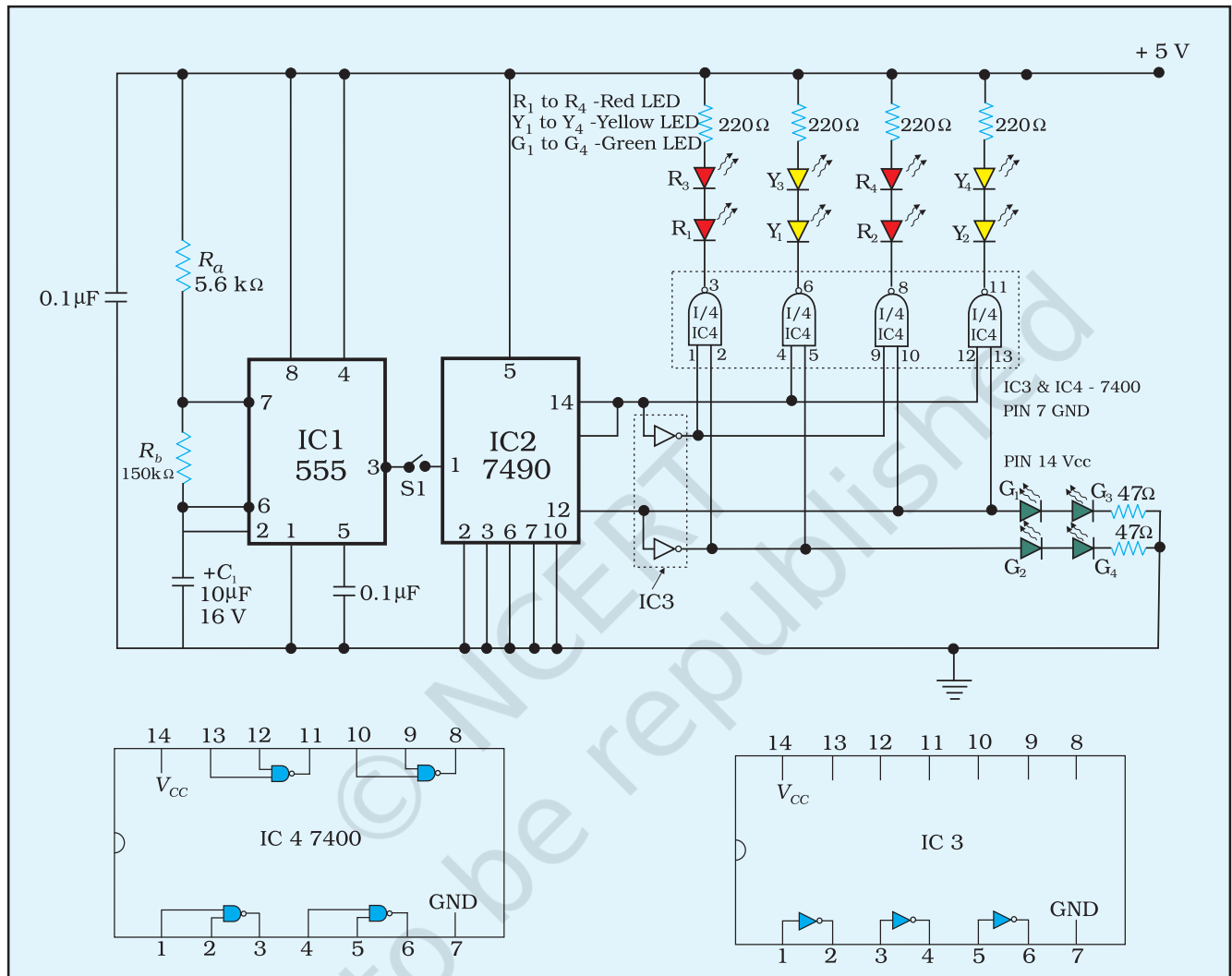

**Fig. P 5.2** Circuit diagram of basic circuit for automatic traffic light system

IC 7490 is a decade counter. As the name suggests, it produces one output pulse for every 10 input pulses.

IC 555 is a highly stable timing circuit capable of producing accurate time delays or oscillations. The time period is controlled by an external resistor-capacitor combination. There is also a provision for triggering and resetting of the timer.

In this traffic light system if the red light will remain ON for 8 seconds (or 8 units of time), the yellow light for 2 seconds and green light for 10 seconds then the ratio of timings of red, yellow and green lights is

4:1:5. IC 555 acts as a timer IC which works on the principle of charging and discharging of a capacitor connected in series with the resistor and that gives high or low output after a regular interval of time. In the present situation, it is used to give a square wave output whose time period can be varied by using suitable values of resistances  $R_a$  and  $R_b$  and capacitance  $C_1$ . The time period of such timer is given by

$$T = 0.693 (R_a + R_b) C_1 \sim 0.693 R_a C_1 \text{ since } R_a \gg R_b$$

IC 7490 performs the function of a decade counter.

## PROCEDURE

1. Connect the components as per the circuit arrangement shown in Fig. P 5.1.
2. Take a plywood board and paint it in black colour (road colour).
3. Mount the LEDs  $R_1, Y_1, G_1; R_2, Y_2, G_2; R_3, Y_3, G_3; R_4, Y_4, G_4$  on four different strips and fix the four strips on the suitable four sides of the road crossing.
4. Check the circuit connections twice and close the switch  $S_1$  for functioning of the traffic light system.

## OBSERVATIONS

**Table P 5.1 : Requirements of lights to remain ON at different counts of time (1:ON, 0:OFF)**

Units of time (s)	$R_1, R_3$	$Y_1, Y_3$	$G_1, G_3$	$R_2, R_4$	$Y_2, Y_4$	$G_2, G_4$
0 to 3	1	0	0	0	0	1
4	0	1	0	0	0	1
5 to 8	0	0	1	1	0	0
9	0	0	1	0	1	0

## RESULT

By closing the switch  $S_1$  the traffic light system starts action for demonstration.

## P RECAUTIONS

---

1. Take sufficient care in soldering the components used in the circuit arrangement in order to avoid dry solder joints.
2. Use IC base so as not to damage the IC by directly soldering it.

## S SELF ASSESSMENT

---

1. Design a circuit for traffic signal system using LEDs and a delay circuit only.
2. Design the basic gates (OR, AND, NOT) using NAND gates.

© NCERT  
not to be republished

# PROJECT 6

## AIM

To study the luminosities of various electric lamps of different powers and make.

## APPARATUS AND MATERIAL REQUIRED

Optical bench with suitable stands, Bunsen's grease spot photometer, bulbs of different powers and make, one standard lamp.

## DESCRIPTION OF APPARATUS

Description of Bunsen's grease spot photometer:

A matt paper is fixed in a circular frame and a grease spot is formed at its centre which leaves the paper translucent at that place. The screen so formed is fixed on a vertical stand which rests at the mid point of the optical bench. On one side of the photometer is mounted a standard lamp and on the other side an electric bulb in such a way that the filaments of the two bulbs and grease spot are in the same line as the bed of the optical bench.

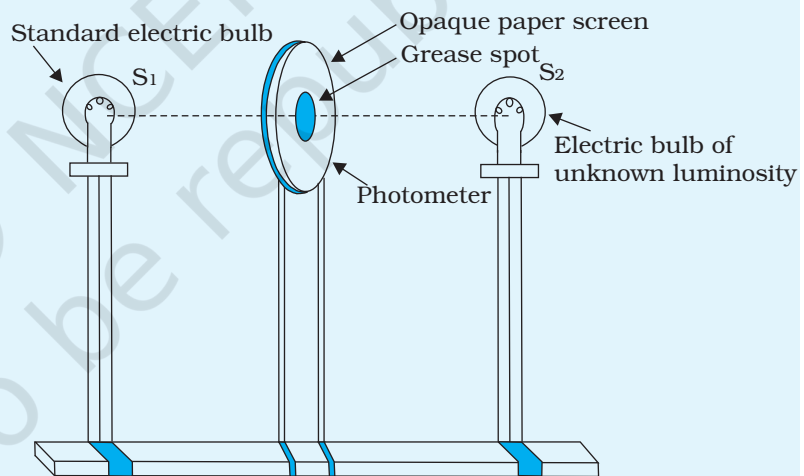

**Fig. P 6.1** A grease spot photometer

## TERMS AND DEFINITIONS

1. **Photometry:** The branch of Physics, which deals with the study of luminosities of different sources of light in the visible range and the intensities of illuminations of surfaces.

2. *Illuminating power or luminosity (L) of a source*: It is defined as the amount of energy in the visible range falling per second per unit surface area held at a unit distance from the source when surface is held normal to the light rays. It is denoted by  $L$ . Its unit is candela.
3. *Luminous flux*: It is defined as the total energy in the visible range emitted per second by a source in all directions. Its SI unit is lumen.
4. *Intensity of illumination (I) at a point on a surface*: It is defined as the amount of energy in the visible range falling per second per unit area of the surface around that point. Its SI unit is Lux.
5. *Brightness of a surface (B)*: Brightness of a surface in a given direction is defined as luminosity coming from the unit area of the surface.

## RELATIONSHIP

The luminous flux  $\phi$ , luminosity  $L$ , and intensity of illumination  $I$  are related by the following equation,

(P 6.1)

$$\phi = 4\pi L$$

(P 6.2)

$$I = \phi/4\pi r^2$$

(P 6.3)

$$I = L/r^2$$

(P 6.4)

$$\text{and } B = IR$$

where  $R$  is the reflection coefficient ( $0 < R < 1$ ) of the surface,  $I$  = intensity of illumination of the source and  $r$  is the distance of the surface from the source.

## PRINCIPLE

According to the principle of photometry, if two surfaces, illuminated by two different sources of light, have the same brightness, then the illuminating powers of the two sources are directly proportional to the square of their respective distances from the surfaces, of the same  $R$ , thus

(P 6.5)

$$\frac{L_1}{L_2} = \frac{r_1^2}{r_2^2}$$

## THEORY

In a grease spot photometer, two sources of light  $S_1$  and  $S_2$  are placed on opposite sides of the screen at such distances that the grease spot and remaining surface of the screen appear equally bright. In that case, the intensity of the two sides of the screen will be the same.

Let  $I_1$  and  $I_2$  be the intensities of illuminations of the screen due to the sources  $S_1$  and  $S_2$  of illuminating powers  $L_1$  and  $L_2$  placed at distances  $r_1$  and  $r_2$  from the screen.

Then  $I_1 = I_2$  (P 6.6)

or  $\frac{L_1}{r_1^2} = \frac{L_2}{r_2^2}$  (P 6.7)

or  $\frac{L_1}{L_2} = \frac{r_1^2}{r_2^2}$  (P 6.8)

If the source  $S_1$  is taken as a standard source of known illuminating power, then using the relation (P 6.8), the illuminating powers of bulbs of different powers and makes can be found out.

## PROCEDURE

1. Adjust the stand of grease spot screen at a suitable height on the optical bench.
2. Fix the electric lamp of known wattage on one side of the screen and the other electric lamp of different wattage on the other side of the screen.
3. Adjust the heights of the stand or uprights in such a way that the filaments of two bulbs and the centre of the grease spot, all lie in the same horizontal line.
4. Adjust the distances of both the lamps in such a manner that the grease spot and the rest of the surface of the screen appear equally bright.
5. Measure the distances  $r_1$  and  $r_2$  on the optical bench.
6. Find the index correction and use it to get the correct values of  $r_1$  and  $r_2$ .

## OBSERVATIONS

1. Power and make of standard lamp = ...

(a) Bulbs of same wattage but different makes

**Table P 6.1: Illuminating power of the two sources**

No. of Obs.	Make of the bulb	Distance of the bulbs from the screen for		$\frac{L_2}{L_1} = \frac{r_2^2}{r_1^2}$
		Illuminating power $L_1$ $r_1$ (cm)	Illuminating power $L_2$ $r_2$ (cm)	
1				
2				
3				
4				

b. Bulbs of different wattage but of same makes

**Table P 6.1: Illuminating power of the two sources**

No. of Obs.	Wattage of bulb W	Distance of the bulbs from the screen for		$\frac{L_2}{L_1} = \frac{r_2^2}{r_1^2}$
		Illuminating power $L_1$ $r_1$ (cm)	Illuminating power $L_2$ $r_2$ (cm)	
1				
2				
3				
4				

### CALCULATIONS

Find the ratio of  $\frac{L_2}{L_1} = \frac{r_2^2}{r_1^2}$  in each observation for both the tables.

### RESULT

- Bulbs of equal wattage but different makes in decreasing order of luminosity are
  - ...
  - ...
  - ...
  - ...
- Bulbs of same make but different wattage in decreasing order of luminosities are
  - ...
  - ...
  - ...
  - ...



## PRECAUTIONS

1. Lamps should be adjusted at the same height on the optical bench.
2. Index correction should be applied to each observation.
3. The reflection coefficient of the opaque portion of the screen must be unity.

## SOURCES OF ERROR

1. Least count of the optical bench scale limits the accuracy of measurements.
2. It is difficult to determine exactly when the grease spot disappears, i.e., appears as bright as its surroundings.

## DISCUSSION

This method can be used to compare luminous intensities of bulbs of the same power but different makes, to carry out a market survey and find out the bulb of which make is best amongst the examined.

## SELF ASSESSMENT

1. What is luminous flux?
2. State the inverse square law in photometry.
3. If a 100 W bulb is placed at 40 cm on one side of the grease spot screen, where should a 60 W bulb be placed on the other side of the grease spot, so that the grease spot just disappears?
4. Do you expect the luminous flux of a bulb to be equal to the electrical power of the bulb?

### SUGGESTED ADDITIONAL EXPERIMENTS/ACTIVITIES

1. The above method can be extended to compare the luminosities of different bulbs of unknown powers.
2. Try this experiment with a CFL bulb on one side and an incandescent bulb on the other side.

The brightness of opaque portion on the side of the standard bulb will be

$$B_1 = R_1 I_1$$

(P 6.9)

where  $I_1$  is the intensity of illumination of the screen due to the standard bulb and  $R_1$  is the reflection coefficient of the opaque portion. The brightness of the grease spot will be

(P 6.10)

$$B_2 = R_2 I_1 + T_2 I_2$$

where  $R_2$  and  $T_2$  are the reflection and the transmission coefficient, respectively of the grease spot and  $I_2$  is the intensity of illumination of the screen due to the unknown source,

if  $I_1 = I_2$ , we get

(P 6.11)

$$B_2 = (R_2 + T_2) I_1 = R_1 I_1$$

Assuming the absorption coefficient to be zero. From equation P 6.9 and P 6.11, it is clear that for the two brightnesses to be equal,  $R_1$  must be unity.

# PROJECT 7

## A<sub>IM</sub>

To study frequency response of (i) a capacitor (ii) an inductor (iii) LCR series circuit.

### (i) Frequency response of a capacitor

## APPARATUS AND MATERIAL REQUIRED

Paper or mica capacitor (0.1 - 1.0  $\mu\text{F}$ ), digital multimeter (DMM), carbon resistor (1000 $\Omega$ ) and an audio oscillator/signal generator.

## DESCRIPTION OF APPARATUS

Current passing through a capacitor depends on its capacitance and the frequency of the applied sinusoidal alternating voltage. Keeping frequency fixed, variation of current ( $I$ ) with voltage ( $V$ ) is observed and the capacitive reactance  $X_c$  is found out from the slope of the  $V$ - $I$  graphs. In order to measure the current, a carbon resistor  $R_o$  of the order of 1000  $\Omega$  is inserted in the circuit (Fig. P 7.1) and the voltage  $V$  across it is measured with the DMM, in ac voltage mode. So the current in the circuit is  $I = V_R/R_o$ . Setting the oscillator at different frequencies,  $X_c$  is found for different frequencies. A graph between  $X_c$  and frequency  $\nu$  is called the frequency response of the capacitor. A graph between  $X_c^{-1}$  and frequency  $\nu$  is also obtained which is a straight line passing through the origin.

**Note:** A DMM always measures the *rms* values of ac current and voltage. It is always advised not to use the DMM in the ac current mode. These measurements are reliable only for frequencies less than 400 Hz.

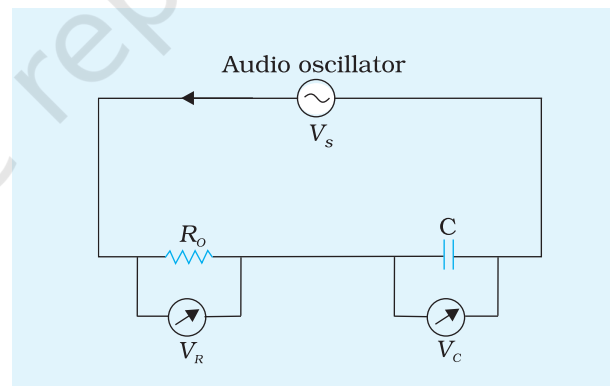

**Fig. P 7.1** Measurement of the reactance of a capacitor

## PROCEDURE

1. Connect the audio oscillator, carbon resistor  $R_o$  and capacitor according to the Fig. P 7.1.
2. Set the oscillator to frequency of 50 Hz and maximum amplitude. The DMM in ac voltage mode is connected across  $C$ , afterwards across  $R_o$  to measure  $V_c$  and  $V_R$  respectively. The different pairs of values of  $V_c$  and  $V_R$  are obtained by changing the amplitude of the applied voltage. The values are recorded in Table P 7.1.
3. The step 2 is repeated with frequencies 100 Hz, 150 Hz, 200 Hz, 250 Hz and 300 Hz and the corresponding values of  $V_c$  and  $V_R$  are also tabulated in Table P 7.1.

## OBSERVATIONS

**Table P 7.1: Measurement of  $X_c$  for different values of  $\nu$ .**

Sl.No.	Amplitude	Frequency, $\nu$ (Hz)	$V_c$ (V)	$V_R$ (V)	$I = V_R/R_o$ (A)	Slope of the $V_c$ - $I$ graph, $X_c$ ( $\Omega$ )
1		50	(i)			
			(ii)			
			(iii)			
			(iv)			
2		100	(i)			
			(ii)			
			(iii)			
			(iv)			
6		300	(i)			
			(ii)			
			(iii)			
			(iv)			

## CALCULATIONS AND GRAPH

For a given frequency, the values of  $I$  are plotted along x-axis and those of  $V_c$  are plotted along y-axis. The gradient ( $\Delta V_c / \Delta I$ ) of the straight line graph (Fig. P 7.2),  $X_c$ , is the capacitive reactance and its value is calculated. The same is done for other frequencies also. The values of  $X_c$  for different frequencies are also included in Table P 7.1. The graph (Fig. P 7.3) obtained by plotting  $X_c$  along y-axis and frequency  $\nu$  along x-axis, gives the frequency response of the capacitor. Now by plotting a graph with  $X_c^{-1}$  along y-axis and frequency  $\nu$  along x-axis a straight line is obtained. From the slope of the straight line graph (Fig. P 7.4)

capacitance  $C$  is calculated using the formula  $C = \frac{1}{2\pi} \left( \frac{p}{q} \right)$

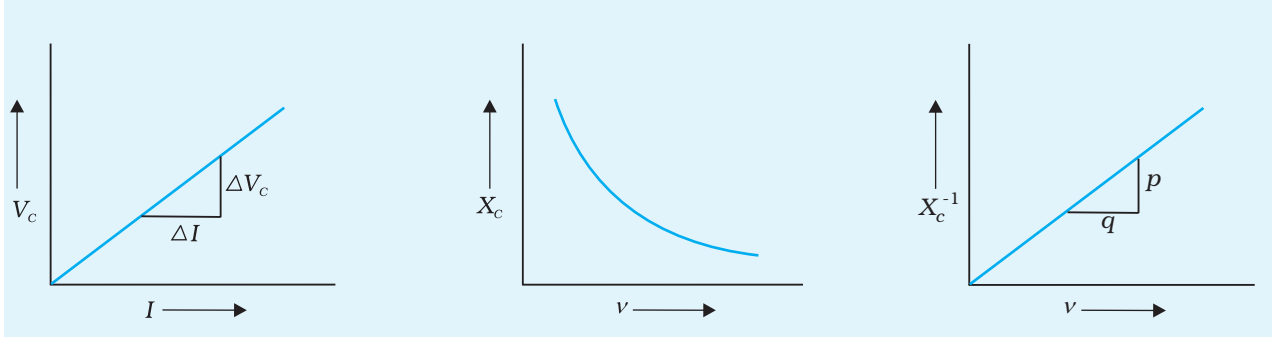

**Fig. P 7.2** Variation of the voltage across the capacitor with the current flowing through it, for a given frequency

**Fig. P 7.3** Variation of  $X_c$  with frequency  $\nu$ .

**Fig. P 7.4** Variation of  $X_c^{-1}$  with frequency

## (ii) Frequency response of an inductor

### APPARATUS AND MATERIAL REQUIRED

An inductor ( $L$ ) of inductance 0.1 H having low resistance, carbon resistor  $R_o$  (100 $\Omega$ ), oscillator with low output impedance, digital multimeter (DMM).

### PRINCIPLE

Current passing through an inductor depends on its inductance and frequency of the applied sinusoidal alternating voltage. Keeping frequency fixed, variation of current ( $I$ ) with voltage ( $V$ ) is observed and the inductive reactance is found out by drawing a straight line graph between  $V$  (along y-axis) and  $I$  (along x-axis). The slope of this graph is the inductive reactance  $X_L = 2\pi\nu L$ , where  $\nu$  is the frequency and  $L$  is the inductance of the inductor, if the inductor is ideal i.e., its resistance  $r$  is zero. If  $r \neq 0$ , the impedance of the inductor is  $Z_L = \sqrt{4\pi^2\nu^2 L^2 + r^2}$ . Setting the oscillator at other frequencies, the inductive reactance  $X_L$  is found out for different frequencies. A graph between frequency  $\nu$  and  $X_L$ , represents frequency response of inductor.

### PROCEDURE

1. The connections are made according to Fig. P 7.1 by replacing capacitor  $C$  with the inductor  $L$  and changing the resistance of the resistor  $R_o$  to 100  $\Omega$ .
2. Making these connections, the values of  $V_L$  and  $V_R$  are found with

DMM for different frequencies from 50 Hz to 300 Hz. The data are tabulated in Table P 7.2. For each frequency, the graph between  $V_R$  and  $I (= V_R/R_o)$  is obtained and inductive reactance  $X_L$  for each frequency is calculated from the slope of this linear graph.

## OBSERVATIONS

**Table P 7. 2: Measurement of  $X_L$  for different values of  $\nu$ .**

Sl.No.	Amplitude	Frequency, $\nu$ (Hz)	$V_L$ (V)	$V_R$ (V)	$I = V_R/R_o$ (A)	Slope of the $V_L$ - $I$ graph, $X_L$ ( $\Omega$ )
1		50	(i)			
			(ii)			
			(iii)			
			(iv)			
2		100	(i)			
			(ii)			
			(iii)			
			(iv)			
6		300	(i)			
			(ii)			
			(iii)			
			(iv)			

## CALCULATIONS AND GRAPH

The values of  $X_L$  for different frequencies are calculated from the slope of the straight line ( $V$ - $I$ ) graphs. Now the frequency response curve for the inductor is obtained by plotting  $X_L$  along y-axis and frequency  $\nu$  along x-axis (Fig. P 7.5).

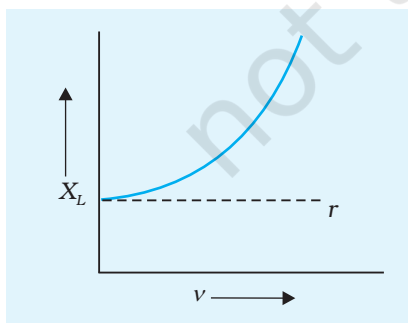

**Fig. P 7.5** Variation of  $X_L$  with  $\nu$

The value of  $X_L$  at  $\nu = 0$  Fig. P 7.5 gives the resistance  $r$  of the inductor. In order to find  $L$ , we plot a graph between  $Z_L^2$  and  $\nu^2$ . The impedance of inductor  $Z_L$  is given as

$$Z_L^2 = 4\pi^2 \nu^2 L^2 + r^2$$

So this graph would be a straight line (Fig. P 7.6).

If the slope of the graph is  $m$  and y intercept is  $c$ , then it is clear that

$$L = \frac{1}{2\pi} \sqrt{m} \quad \text{and} \quad r = \sqrt{c}$$

## DISCUSSION

- (i) If the frequency is very large then  $4\pi^2\nu^2L^2 \gg r^2$ , then at this high frequency range  $Z_L \approx X_L$  and the  $X_L - \nu$  graph is straight line. The slope of this graph at large frequency is equal to  $2\pi L$ , so it is possible to determine the self inductance  $L$  of the inductor from  $X_L - \nu$  graph. But in order to carry out the experiment in this frequency range, DMM is not suitable, cathode ray oscilloscope (CRO) is to be used for measuring voltage. With CRO, the voltages,  $V_L$  and  $V_R$  are actually the measure of amplitudes.
- (ii) If the inductor of inductance  $L$  is replaced by a carbon resistor (or any non-inductive resistor) and the experiment is repeated, then  $V/I = R$  for all frequencies, so the graph between  $R$  versus  $\nu$  is a straight line parallel to  $\nu$ -axis (Fig. P 7.7). Resistance is independent of frequency.
- (iii) **Phasor diagrams**

If the source voltage,  $\mathbf{V}_s$ , in the circuit in Fig. P 7.1 is also measured alongwith the voltage  $\mathbf{V}_c$  across the capacitor and the voltage  $\mathbf{V}_R$  across the resistor  $R_o$  and tabulated in Table P 7.1, then it can be found that

$$\mathbf{V}_s^2 = \mathbf{V}_c^2 + \mathbf{V}_R^2$$

for all observations. This means as if  $\mathbf{V}_c$  and  $\mathbf{V}_R$  are two vectors and in the present case they are perpendicular to each other. Hence, if we draw a triangle ABC, whose length AB is proportional to  $\mathbf{V}_c$ , length AC to  $\mathbf{V}_R$  and length BC to  $\mathbf{V}_s$ , then  $\angle CAB = 90^\circ$ .

This is true for all frequencies. This is due to the fact that  $\mathbf{V}_c$  and  $\mathbf{V}_R$  have different phases and in fact  $\mathbf{V}_R$  leads  $\mathbf{V}_c$  by  $90^\circ$  in phase. This is why they are called phasors.

In case of inductance also it is possible to draw phasor diagrams. Here the voltage  $\mathbf{V}_L$  across a pure inductor (having no resistance of its own) when connected in series with a resistor  $R$  and an audio oscillator (having a small impedance), leads over  $\mathbf{V}_R$ , the voltage across the resistor  $R$ . So,

$$\mathbf{V}_s^2 = \mathbf{V}_R^2 + \mathbf{V}_L^2$$

But in reality, an inductor always has a small but finite resistance  $r$  and so if a triangle, called voltage triangle ABC is drawn and  $\mathbf{V}_s \propto BC$ ,  $\mathbf{V}_L \propto AB$  and  $\mathbf{V}_R \propto AC$ , then the  $\angle BAC$  is not  $90^\circ$ .

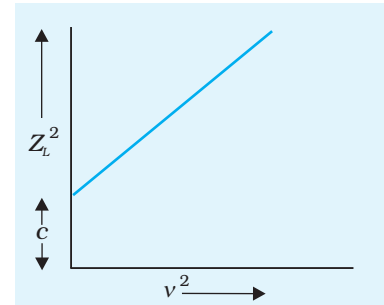

Fig. P 7.6 Variation of  $Z_L^2$  with  $\nu^2$

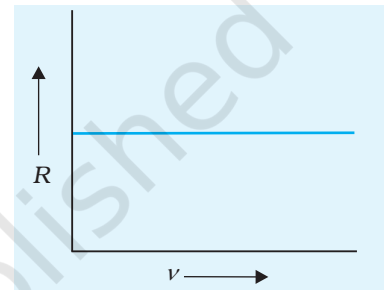

Fig. P 7.7 Variation of  $R$  with  $\nu$

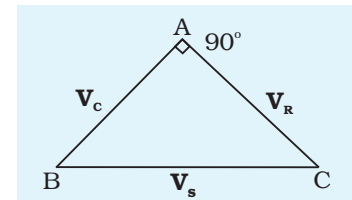
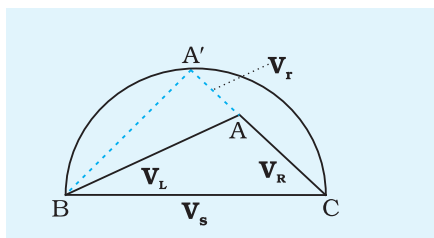

Fig. P 7.8 Phasor diagram for C-R circuit



**Fig. P 7.9** Phasor diagram for L-R circuit

But if we draw a semicircle with BC as the diameter and CA is produced to meet the circle at A' then CA' represents the voltage drop across the total resistance ( $R+r$ ) in the circuit. Here  $V_r \propto AA'$  and BA' represents the voltage drop across the pure inductor.

$$\text{Then, } BC^2 = BA'^2 + CA'^2$$

This can be verified by using a CRO which can measure the phase difference between the various voltages.

### (iii) Frequency response of LCR series circuit

#### APPARATUS AND MATERIAL REQUIRED

Audio oscillator with frequency scale, a resistance box, a digital voltmeter, a  $4\mu\text{F}$  capacitor, (if  $4\mu\text{F}$  is not available; it can be made using a few low valued capacitors in parallel), an inductor of  $\sim 100\text{ mH}$ , connecting wires.

#### PROCEDURE

1. Connect the circuit as shown in Fig. P 7.10. The resistor  $R \sim 100\ \Omega$  is connected in series with  $L$  and  $C$ .

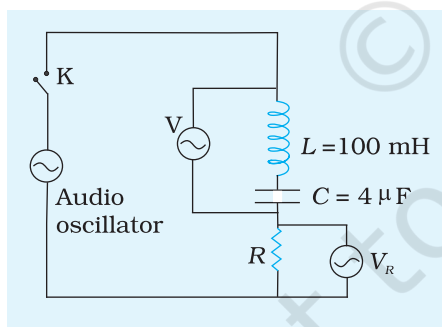

**Fig. P 7.10** LCR series resonance circuit

2. Set the signal output to a low value say 2 V, when the switch K is kept open. Keep this setting fixed throughout the experiment so that output voltage  $V_c$  is same at all values of frequencies. (Keep the frequency below 400 Hz, otherwise digital meter readings will not be reliable).

3. Set the signal generator at some low frequency say 100 Hz and record its value.

4. Measure the voltage  $V_R$  across the known resistor  $R$ . So the current flowing in the circuit is  $I = \frac{V_R}{R}$ .

5. Next measure the voltage  $V$  across the LC combination (All voltages are root mean square (rms) values)

Then impedance of the LC combination is  $Z = V/I$ .

6. Calculate  $I' = \frac{IV_o}{V}$  where  $V_o$  is some fixed value of voltage.

Repeat steps four and five for different frequencies.



## OBSERVATIONS AND CALCULATIONS

Output voltage of generator,  $V_o = \dots$

**Table P 7. 3: Measurement of  $Z$  for different values of  $\nu$ .**

Sl. No.	$\nu$ (Hz)	$I$ (mA)	$V$ (volt)	$I' = \frac{IV_o}{V}$ (A)	$Z = \frac{V}{I}$ ( $\Omega$ )
1					
2					
...					
6					

Inductance,  $L = \dots$

Capacitance,  $C = \dots$

Resonant frequency,  $\nu_r = \frac{1}{2\pi\sqrt{LC}} \dots \text{Hz.}$

## GRAPH

Plot graphs to observe variation of (i) current  $I'$  with frequency (ii) voltage  $V$  with frequency and (iii) impedance  $Z$  with frequency. Observe the resonant frequency from the three graphs and compare their values.

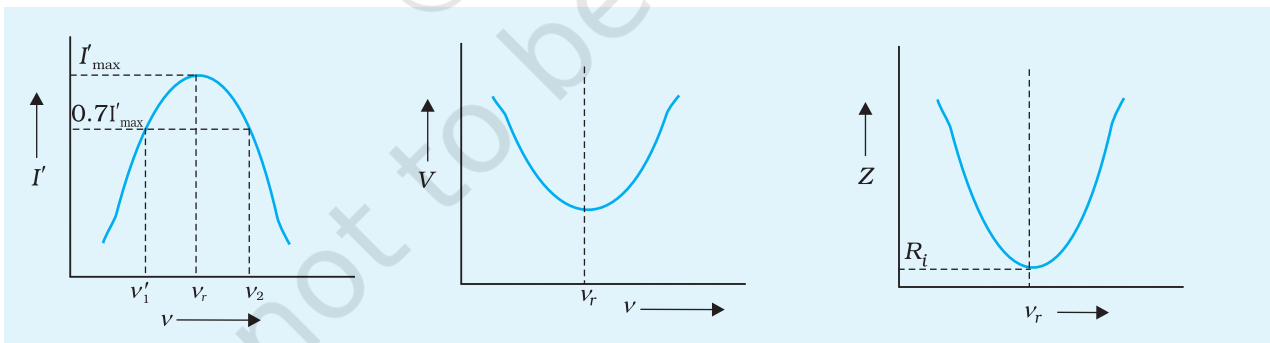

**Fig. P 7.11** The nature of (a) current  $I'$  vs frequency (b) voltage  $V$  across LC combination vs frequency, (c) impedance  $Z$  of LC combination versus frequency.

## RESULT

1. Resonant frequency from  $I'$  vs  $\nu$  graph = ... Hz
2. Resonant frequency from  $V$  vs  $\nu$  graph = ... Hz

3. Resonant frequency from  $Z$  vs  $\nu$  graph = ...Hz
4. Minimum value of  $Z$  i.e., internal resistance  $R_i$  from  $Z$  versus  $\nu$  graph = ...  $\Omega$  (should be around  $\sim 100 \Omega$ )

## DISCUSSION

1. Have you wondered, why to perform the experiment at low voltage? As you approach to resonant frequency  $\nu_r$ , both  $V_L$  and  $V_C$  increase enormously. Therefore, it may cause damage to insulation of electrical components. This is the reason for setting up the generator at low voltage. Ensure that the capacitor and inductor are rated atleast 300 V.
2. *Phase relation between  $X_L$  and  $X_C$* : For frequencies, quite far away from resonant frequency, individual voltages  $V_L$  and  $V_C$  may be larger than the output voltage of the oscillator and  $V$  is quite closely equal to their difference. Check up this fact at one or two frequencies by actually measuring  $V_L$  and  $V_C$ .

Obviously, it shows that inductive and capacitive reactance are opposite in character, i.e., voltage across inductor and the capacitor are in a phase opposite to each other. The ac current in circuit lags behind voltage  $V_L$  by  $90^\circ$  and  $V_C$  lags behind the ac current by further  $90^\circ$ . Hence  $V_L$  and  $V_C$  are  $180^\circ$  out of phase with each other.

3. *Internal resistant of resonance circuit*– Resonance in the circuit is observed when  $X_L$  and  $X_C$  are equal to each other. In case of ideal inductor and capacitor their combined reactance would be zero at resonance. It will cause an infinite current at resonance, except that it is limited by the output impedance of the signal generator. Internal resistance  $R_i$  in an inductive coil is due to finite resistance of its windings and some hysteresis losses in its iron core. In case of a capacitor, there is energy losses in the dielectric. The minimum value of  $X$  at resonance represents this internal

resistance  $R_i$ . It can be calculated as  $R_i = \frac{V_{\min}}{I_{\max}}$

4. **Quality factor**

The magnitude of voltage drop across  $L$  at resonance is

$$V_L = X_L I_{\max} = 2\pi\nu_r L \frac{V_{\min}}{R_i}$$

$$= Q_0 V_{\min}$$

Here  $Q_0 = \frac{2\pi\nu_r L}{R_i} = \frac{1}{2\pi\nu_r C R_i}$  is the quality factor at resonance.

It is the ratio of reactance of  $L$  (or of  $C$ ) to the value of  $X$ , both taken at resonant frequency  $\nu_r$ . Since  $Q_0$  is a number greater than 1, the voltage drop across  $C$  or  $L$  would be greater than  $V_{\min}$ , the voltage drop across  $L$  and  $C$  combine together.

Calculate the value of  $Q_0$ , knowing the values of  $\nu_r$ ,  $R$ ,  $L$  and  $C$ .

#### SUGGESTED ADDITIONAL EXPERIMENTS/ACTIVITIES

1. Take a capacitor whose capacitance is not known. Connect it in series with an inductor of inductance  $L$  and measure their frequencies by series resonant circuit. Find the value of unknown capacitance using the equation,

$$\nu_r = 1 / 2\pi(\sqrt{LC})$$

2. Take an inductor whose inductance is not known. Repeat the above procedure to find out its value.
3. Change the resistance of  $LCR$  series circuit at three different values. In each of the three sets of observations for  $I$  as a function of frequency  $\nu$ , convert values of  $I$  to  $I'$ , where  $I'$  is current that would pass keeping  $V = V_0$ . Then convert values of  $I$  as percentages of

its value at resonance in that set. Plot  $\frac{I}{I'}$  (in percentage) versus frequency graph as shown in Fig. P 7.12. Compare values of  $Q_0$ ,  $Q_1$  and  $Q_2$ . Do you find that with smaller values of  $R$ , the resonance is sharper? Discuss your result.

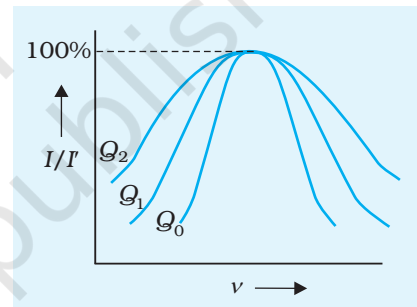

4. *Half points:* Find two frequencies  $\nu_1$  and  $\nu_2$  on  $I$ - $\nu$  graph Fig. P 7.11 (a) where the current has its value equal to 70% of the current at resonance. These frequencies are known as half points, because the power consumed in the circuit at these frequencies is half the power consumed at resonance subject to condition that constant ac potential difference is applied to the resonance circuit. Find the difference  $\nu_2 - \nu_1$ .

**Fig. P 7.12**  $(I/I')$  versus frequency