

UNIT 6

TRIANGLES

(A) Main Concepts and Results

- The six elements of a triangle are its three angles and the three sides.
- The line segment joining a vertex of a triangle to the mid point of its opposite side is called a median of the triangle. A triangle has 3 medians.
- The perpendicular line segment from a vertex of a triangle to its opposite side is called an altitude of the triangle. A triangle has 3 altitudes.
- An exterior angle of a triangle is formed, when a side of a triangle is produced.
- The measure of any exterior angle of a triangle is equal to the sum of the measures of its two interior opposite angles.
- The sum of the three angles of a triangle is 180° .
- A triangle is said to be equilateral, if each of its sides has the same length.
- In an equilateral triangle, each angle has measure 60° .
- A triangle is said to be isosceles if at least two of its sides are of same length.
- The sum of the lengths of any two sides of a triangle is always greater than the length of the third side.
- The difference of the lengths of any two sides of a triangle is always smaller than the length of the third side.

- In a right-angled triangle, the side opposite to the right angle is called the hypotenuse and the other two sides are called its legs or arms.
- In a right-angled triangle, the square of the hypotenuse is equal to the sum of the squares on its legs.
- Two plane figures, say, F_1 and F_2 are said to be congruent, if the trace-copy of F_1 fits exactly on that of F_2 . We write this as $F_1 \cong F_2$.
- Two line segments, say \overline{AB} and \overline{CD} , are congruent, if they have equal lengths. We write this as $\overline{AB} \cong \overline{CD}$. However, it is common to write it as $\overline{AB} = \overline{CD}$.
- Two angles, say $\angle ABC$ and $\angle PQR$, are congruent, if their measures are equal. We write this as $\angle ABC \cong \angle PQR$ or as $m \angle ABC = m \angle PQR$ or simply as $\angle ABC = \angle PQR$.
- Under a given correspondence, two triangles are congruent, if the three sides of the one are equal to the three sides of the other (SSS).
- Under a given correspondence, two triangles are congruent if two sides and the angle included between them in one of the triangles are equal to the two sides and the angle included between them of the other triangle (SAS).
- Under a given correspondence, two triangles are congruent if two angles and the side included between them in one of the triangles are equal to the two angles and the side included between them of the other triangle (ASA).
- Under a given correspondence, two right-angled triangles are congruent if the hypotenuse and a leg (side) of one of the triangles are equal to the hypotenuse and one of the leg (side) of the other triangle (RHS).

(B) Solved Examples

In Examples 1 to 5, there are four options, out of which only one is correct. Write the correct one.

- Example 1:** In Fig. 6.1, side QR of a ΔPQR has been produced to the point S. If $\angle PRS = 115^\circ$ and $\angle P = 45^\circ$, then $\angle Q$ is equal to,
 (a) 70° (b) 105° (c) 51° (d) 80°

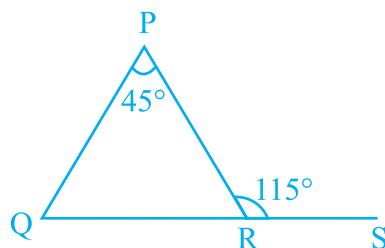

Fig. 6.1

Solution: Correct answer is (a).

Example 2: In an equilateral triangle ABC (Fig. 6.2), AD is an altitude. Then $4AD^2$ is equal to

- (a) $2BD^2$ (b) BC^2 (c) $3AB^2$ (d) $2DC^2$

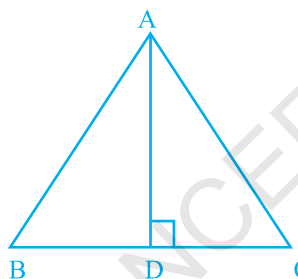

Fig. 6.2

Solution: Correct answer is (c).

Example 3: Which of the following cannot be the sides of a triangle?

- (a) 3 cm, 4 cm, 5 cm (b) 2 cm, 4 cm, 6 cm
 (c) 2.5 cm, 3.5 cm, 4.5 cm (d) 2.3 cm, 6.4 cm, 5.2 cm

Solution: Correct answer is (b).

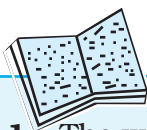

Vocabulary

- The word equilateral contains the roots *equi*, which means “equal,” and *lateral*, which means “of the side.” What do you suppose an equilateral is?
- The Greek prefix *poly* means “many,” and the root *gon* means “angle.” What do you suppose a *polygon* is?

Example 4: Which one of the following is not a criterion for congruence of two triangles?

- (a) ASA (b) SSA (c) SAS (d) SSS

Solution: Correct answer is (b).

Example 5: In Fig. 6.3, PS is the bisector of $\angle P$ and $PQ = PR$. Then ΔPRS and ΔPQS are congruent by the criterion

- (a) AAA (b) SAS (c) ASA (d) both (b) and (c)

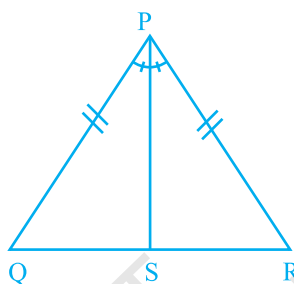

Fig. 6.3

Solution : Correct answer is (b).

In examples 6 to 9, fill in the blanks to make the statements true.

Example 6: The line segment joining a vertex of a triangle to the mid-point of its opposite side is called its _____.

Solution: median

Example 7: A triangle is said to be _____, if each one of its sides has the same length.

Solution: equilateral

Example 8: In Fig. 6.4, $\angle PRS = \angle QPR + \angle$ _____

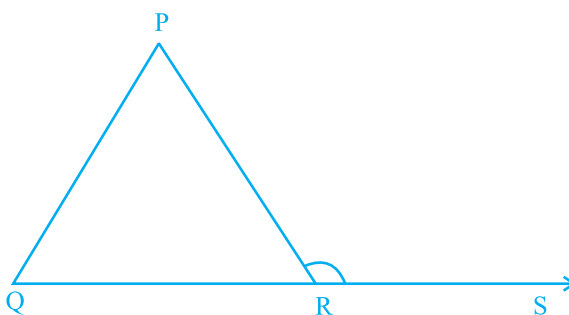

Fig. 6.4

Solution: PQR

Example 9: Let ABC and DEF be two triangles in which $AB = DE$, $BC = FD$ and $CA = EF$. The two triangles are congruent under the correspondence

$ABC \leftrightarrow$ _____

Solution: EDF

In Examples 10 to 12, state whether the statements are True or False.

Example 10: Sum of any two sides of a triangle is not less than the third side.

Solution: False

Example 11: The measure of any exterior angle of a triangle is equal to the sum of the measures of its two interior opposite angles.

Solution: True

Example 12: If in $\triangle ABC$ and $\triangle DEF$, $AB = DE$, $\angle A = \angle D$ and $BC = EF$ then the two triangle ABC and DEF are congruent by SAS criterion.

Solution: False

Application on Problem Solving Strategy



Example 13
In Fig. 6.5, find x and y .

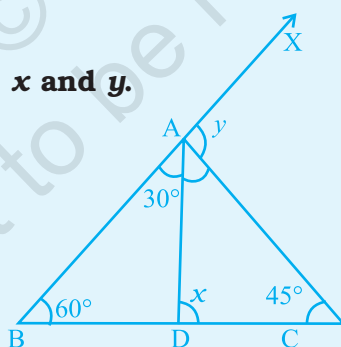

Fig. 6.5

Solution :



Understand and Explore the Problem

- What all are given?
 $\angle ABD = 60^\circ$, $\angle BAD = 30^\circ$ and $\angle ACD = 45^\circ$
- What are to be found?
 $\angle ADC$ and $\angle XAC$, which are respectively exterior angles for $\triangle ABD$ and $\triangle ABC$.



Plan a Strategy

- Find $\angle ADC$ using exterior angle property for $\triangle ABD$.
- Find y using exterior angle property for $\triangle ABC$.



Solve

- $x = \angle ADC = \angle DBA + \angle BAD$ (In $\triangle ABD$)
 $= 60^\circ + 30^\circ$
 $= 90^\circ$
- $y = \angle XAC = \angle ABC + \angle ACB$ (In $\triangle ABC$)
 $= 60^\circ + 45^\circ$
 $= 105^\circ$



Revise

- Verify your answer by using some other properties of triangle.
 In $\triangle ABD$, $\angle ADB = 180^\circ - (30^\circ + 60^\circ) = 90^\circ$ (Angle sum property of a triangle)

$$x = \angle ADC = 180^\circ - \angle ADB$$

$$= 180^\circ - 90^\circ = 90^\circ, \text{ Hence, } \angle ADC = 90^\circ \text{ verified.}$$

$$\angle DAC = 180^\circ - (x + 45^\circ) = 180^\circ - 135^\circ = 45^\circ$$

At point A on \overline{BAX} , $30^\circ + \angle DAC + y = 180^\circ$

Hence for verifying value of y , $30^\circ + 45^\circ + y = 180^\circ$
 or $y = 180^\circ - 75^\circ = 105^\circ$

Think and Discuss

1. If $AD = DC$? Why?
2. In given problem, can $\angle B$ be 85° instead of 60° ? If yes find the values of x and y in that case.
3. What type of triangle is $\triangle ADC$?

(C) Exercise

In each of the questions 1 to 49, four options are given, out of which only one is correct. Choose the correct one.

1. The sides of a triangle have lengths (in cm) 10, 6.5 and a , where a is a whole number. The minimum value that a can take is
 (a) 6 (b) 5 (c) 3 (d) 4

2. Triangle DEF of Fig. 6.6 is a right triangle with $\angle E = 90^\circ$.

What type of angles are $\angle D$ and $\angle F$?

- (a) They are equal angles
 (b) They form a pair of adjacent angles
 (c) They are complementary angles
 (d) They are supplementary angles

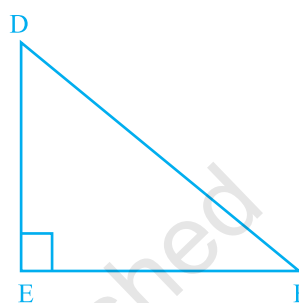

Fig. 6.6

CONGRUENT TRIANGLES

Diagram	Statement	Corresponding Angles	Corresponding Sides
	$\triangle ABC \cong \triangle DEF$	$\angle A \cong \angle D$ $\angle B \cong \angle E$ $\angle C \cong \angle F$	$\overline{AB} \cong \overline{DE}$ $\overline{BC} \cong \overline{EF}$ $\overline{AC} \cong \overline{DF}$

3. In Fig. 6.7, $PQ = PS$. The value of x is

- (a) 35° (b) 45°
 (c) 55° (d) 70°

4. In a right-angled triangle, the angles other than the right angle are

- (a) obtuse (b) right
 (c) acute (d) straight

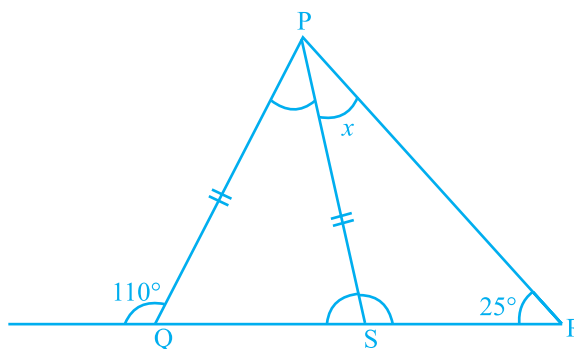

Fig. 6.7

5. In an isosceles triangle, one angle is 70° . The other two angles are of
 (i) 55° and 55° (ii) 70° and 40° (iii) any measure

In the given option(s) which of the above statement(s) are true?

- (a) (i) only (b) (ii) only (c) (iii) only (d) (i) and (ii)

6. In a triangle, one angle is of 90° . Then

- (i) The other two angles are of 45° each
 (ii) In remaining two angles, one angle is 90° and other is 45°
 (iii) Remaining two angles are complementary

In the given option(s) which is true?

- (a) (i) only (b) (ii) only (c) (iii) only (d) (i) and (ii)

7. Lengths of sides of a triangle are 3 cm, 4 cm and 5 cm. The triangle is

- (a) Obtuse angled triangle (b) Acute-angled triangle
 (c) Right-angled triangle (d) An Isosceles right triangle

8. In Fig. 6.8, $PB = PD$. The value of x is

- (a) 85° (b) 90°
 (c) 25° (d) 35°

9. In $\triangle PQR$,

- (a) $PQ - QR > PR$
 (b) $PQ + QR < PR$
 (c) $PQ - QR < PR$
 (d) $PQ + PR < QR$

10. In $\triangle ABC$,

- (a) $AB + BC > AC$ (b) $AB + BC < AC$
 (c) $AB + AC < BC$ (d) $AC + BC < AB$

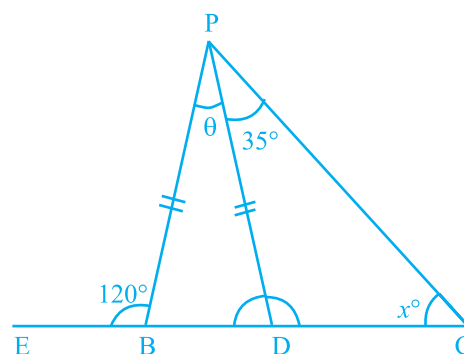

Fig. 6.8

Think and Discuss

1. **Explain** what it means for two polygons to be congruent.
2. **Tell** how to write a congruence statement for two triangles.

11. The top of a broken tree touches the ground at a distance of 12 m from its base. If the tree is broken at a height of 5 m from the ground then the actual height of the tree is
 (a) 25 m (b) 13 m (c) 18 m (d) 17 m
12. The triangle ABC formed by $AB = 5$ cm, $BC = 8$ cm, $AC = 4$ cm is
 (a) an isosceles triangle only (b) a scalene triangle only
 (c) an isosceles right triangle (d) scalene as well as a right triangle
13. Two trees 7 m and 4 m high stand upright on a ground. If their bases (roots) are 4 m apart, then the distance between their tops is
 (a) 3 m (b) 5 m (c) 4 m (d) 11 m
14. If in an isosceles triangle, each of the base angles is 40° , then the triangle is
 (a) Right-angled triangle (b) Acute angled triangle
 (c) Obtuse angled triangle (d) Isosceles right-angled triangle
15. If two angles of a triangle are 60° each, then the triangle is
 (a) Isosceles but not equilateral (b) Scalene
 (c) Equilateral (d) Right-angled
16. The perimeter of the rectangle whose length is 60 cm and a diagonal is 61 cm is
 (a) 120 cm (b) 122 cm (c) 71 cm (d) 142 cm
17. In $\triangle PQR$, if $PQ = QR$ and $\angle Q = 100^\circ$, then $\angle R$ is equal to
 (a) 40° (b) 80° (c) 120° (d) 50°
18. Which of the following statements is not correct?
 (a) The sum of any two sides of a triangle is greater than the third side
 (b) A triangle can have all its angles acute
 (c) A right-angled triangle cannot be equilateral
 (d) Difference of any two sides of a triangle is greater than the third side
19. In Fig. 6.9, $BC = CA$ and $\angle A = 40^\circ$. Then, $\angle ACD$ is equal to
 (a) 40° (b) 80°
 (c) 120° (d) 60°

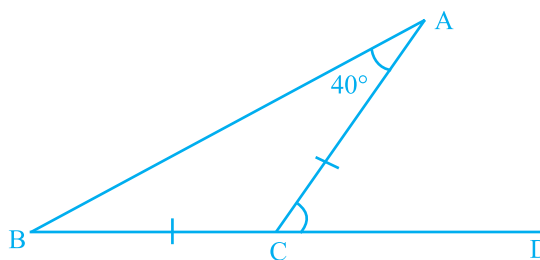

Fig. 6.9

- 20.** The length of two sides of a triangle are 7 cm and 9 cm. The length of the third side may lie between
- 1 cm and 10 cm
 - 2 cm and 8 cm
 - 3 cm and 16 cm
 - 1 cm and 16 cm

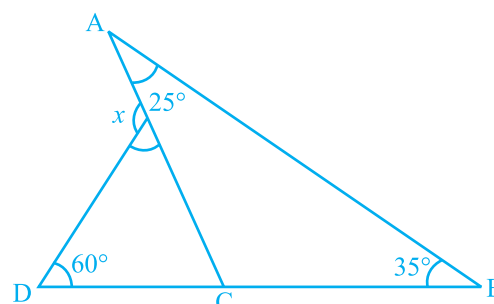

Fig. 6.10

- 21.** From Fig. 6.10, the value of x is
- 75°
 - 90°
 - 120°
 - 60°

- 22.** In Fig. 6.11, the value of $\angle A + \angle B + \angle C + \angle D + \angle E + \angle F$ is
- 190°
 - 540°
 - 360°
 - 180°

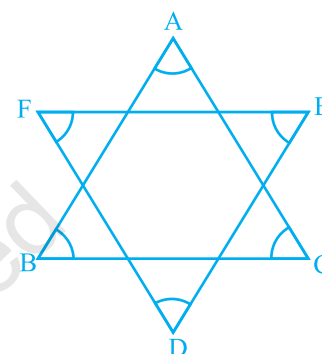

Fig. 6.11

- 23.** In Fig. 6.12, $PQ = PR$, $RS = RQ$ and $ST \parallel QR$. If the exterior angle RPU is 140° , then the measure of angle TSR is
- 55°
 - 40°
 - 50°
 - 45°

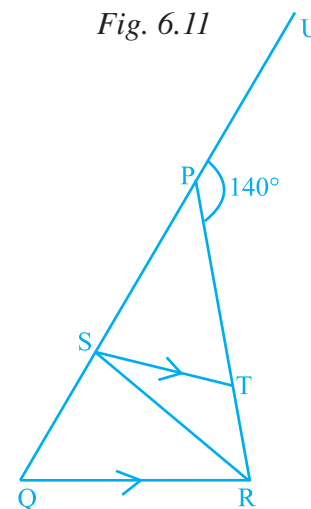

Fig. 6.12

- 24.** In Fig. 6.13, $\angle BAC = 90^\circ$, $AD \perp BC$ and $\angle BAD = 50^\circ$, then $\angle ACD$ is
- 50°
 - 40°
 - 70°
 - 60°

- 25.** If one angle of a triangle is equal to the sum of the other two angles, the triangle is
- obtuse
 - acute
 - right
 - equilateral

- 26.** If the exterior angle of a triangle is 130° and its interior opposite angles are equal, then measure of each interior opposite angle is
- 55°
 - 65°
 - 50°
 - 60°

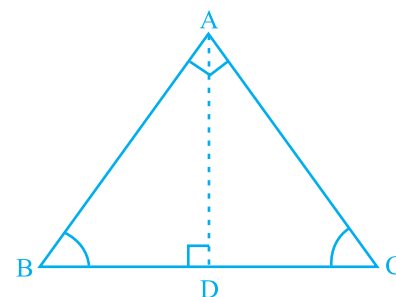

Fig. 6.13

27. If one of the angles of a triangle is 110° , then the angle between the bisectors of the other two angles is
 (a) 70° (b) 110° (c) 35° (d) 145°
28. In $\triangle ABC$, AD is the bisector of $\angle A$ meeting BC at D, $CF \perp AB$ and E is the mid-point of AC. Then median of the triangle is
 (a) AD (b) BE
 (c) FC (d) DE
29. In $\triangle PQR$, if $\angle P = 60^\circ$, and $\angle Q = 40^\circ$, then the exterior angle formed by producing QR is equal to
 (a) 60° (b) 120° (c) 100° (d) 80°
30. Which of the following triplets cannot be the angles of a triangle?
 (a) $67^\circ, 51^\circ, 62^\circ$ (b) $70^\circ, 83^\circ, 27^\circ$
 (c) $90^\circ, 70^\circ, 20^\circ$ (d) $40^\circ, 132^\circ, 18^\circ$
31. Which of the following can be the length of the third side of a triangle whose two sides measure 18 cm and 14 cm?
 (a) 4 cm (b) 3 cm (c) 5 cm (d) 32 cm
32. How many altitudes does a triangle have?
 (a) 1 (b) 3 (c) 6 (d) 9
33. If we join a vertex to a point on opposite side which divides that side in the ratio 1:1, then what is the special name of that line segment?
 (a) Median (b) Angle bisector
 (c) Altitude (d) Hypotenuse
34. The measures of $\angle x$ and $\angle y$ in Fig. 6.14 are respectively
 (a) $30^\circ, 60^\circ$ (b) $40^\circ, 40^\circ$
 (c) $70^\circ, 70^\circ$ (d) $70^\circ, 60^\circ$
35. If length of two sides of a triangle are 6 cm and 10 cm, then the length of the third side can be
 (a) 3 cm (b) 4 cm (c) 2 cm (d) 6 cm
36. In a right-angled triangle ABC, if angle B = 90° , BC = 3 cm and AC = 5 cm, then the length of side AB is
 (a) 3 cm (b) 4 cm (c) 5 cm (d) 6 cm

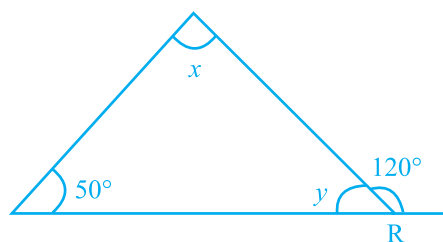

Fig. 6.14

37. In a right-angled triangle ABC, if angle B = 90°, then which of the following is true?
- (a) $AB^2 = BC^2 + AC^2$ (b) $AC^2 = AB^2 + BC^2$
 (c) $AB = BC + AC$ (d) $AC = AB + BC$
38. Which of the following figures will have its altitude outside the triangle?

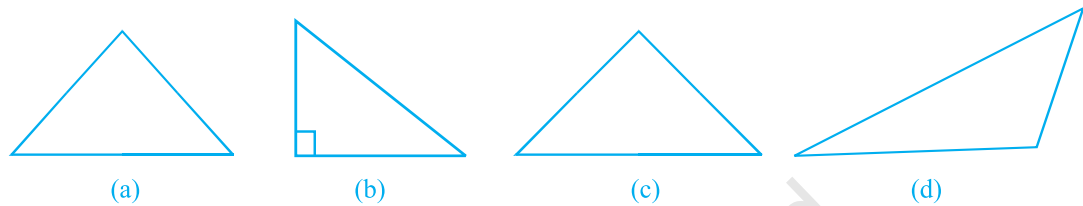
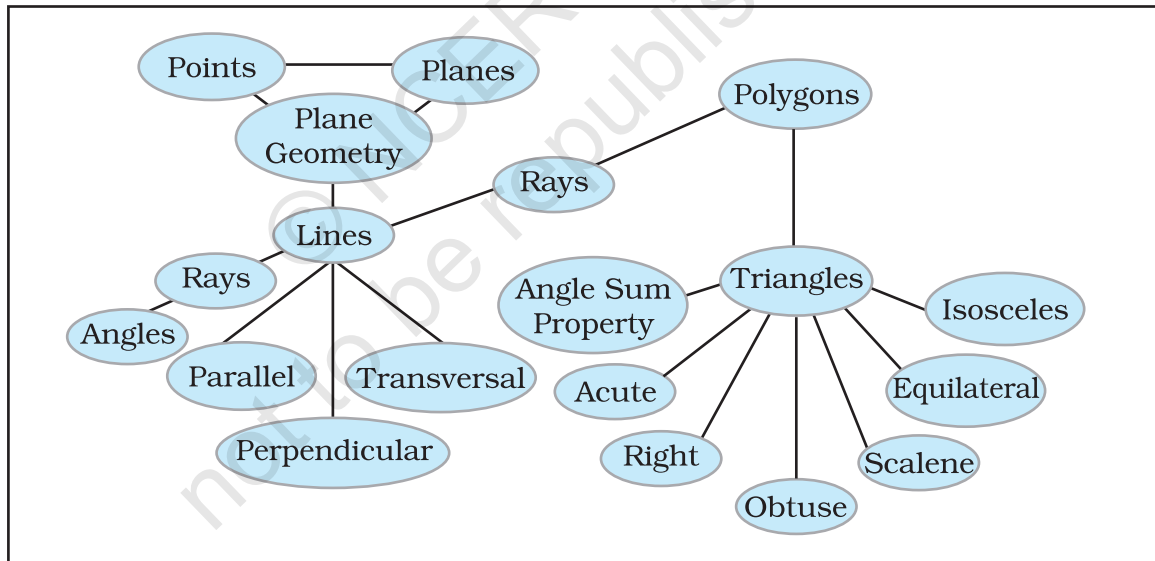

Fig. 6.15



39. In Fig. 6.16, if $AB \parallel CD$, then

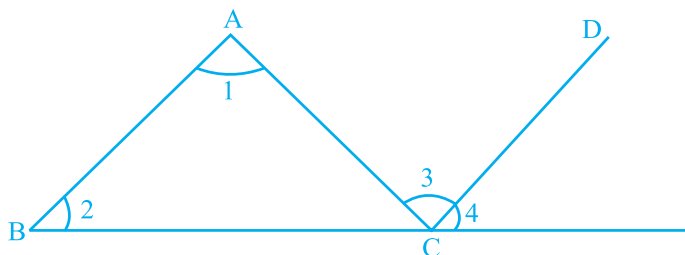

Fig. 6.16

- (a) $\angle 2 = \angle 3$ (b) $\angle 1 = \angle 4$
 (c) $\angle 4 = \angle 1 + \angle 2$ (d) $\angle 1 + \angle 2 = \angle 3 + \angle 4$

40. In $\triangle ABC$, $\angle A = 100^\circ$, AD bisects $\angle A$ and $AD \perp BC$. Then, $\angle B$ is equal to
 (a) 80° (b) 20° (c) 40° (d) 30°
41. In $\triangle ABC$, $\angle A = 50^\circ$, $\angle B = 70^\circ$ and bisector of $\angle C$ meets AB in D (Fig. 6.17). Measure of $\angle ADC$ is.

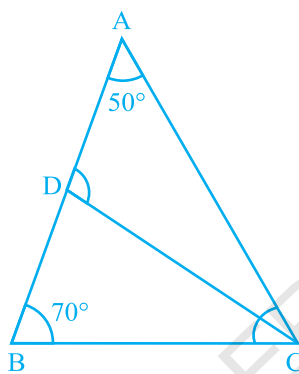

Fig. 6.17

- (a) 50° (b) 100° (c) 30° (d) 70°
42. If for $\triangle ABC$ and $\triangle DEF$, the correspondence $CAB \leftrightarrow EDF$ gives a congruence, then which of the following is not true?
 (a) $AC = DE$ (b) $AB = EF$
 (c) $\angle A = \angle D$ (d) $\angle C = \angle E$

43. In Fig. 6.18, M is the mid-point of both AC and BD . Then

- (a) $\angle 1 = \angle 2$ (b) $\angle 1 = \angle 4$
 (c) $\angle 2 = \angle 4$ (d) $\angle 1 = \angle 3$

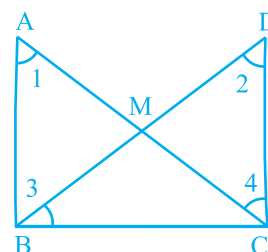

Fig. 6.18

44. If D is the mid-point of the side BC in $\triangle ABC$ where $AB = AC$, then $\angle ADC$ is
 (a) 60° (b) 45°
 (c) 120° (d) 90°

45. Two triangles are congruent, if two angles and the side included between them in one of the triangles are equal to the two angles and the side included between them of the other triangle. This is known as the
- RHS congruence criterion
 - ASA congruence criterion
 - SAS congruence criterion
 - AAA congruence criterion

46. By which congruency criterion, the two triangles in Fig. 6.19 are congruent?

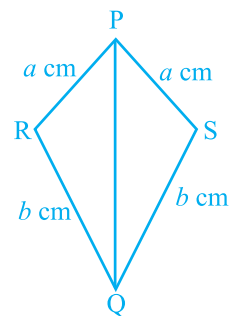

Fig. 6.19

- RHS
 - ASA
 - SSS
 - SAS
47. By which of the following criterion two triangles cannot be proved congruent?
- AAA
 - SSS
 - SAS
 - ASA
48. If $\triangle PQR$ is congruent to $\triangle STU$ (Fig. 6.20), then what is the length of TU?
- 5 cm
 - 6 cm
 - 7 cm
 - cannot be determined

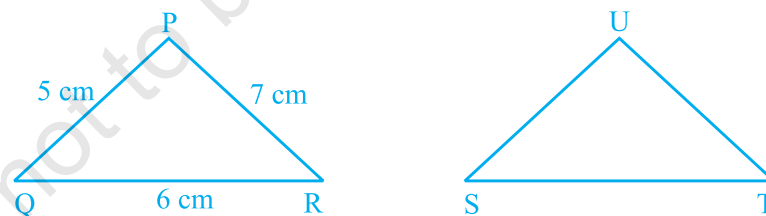

Fig. 6.20

49. If $\triangle ABC$ and $\triangle DBC$ are on the same base BC, $AB = DC$ and $AC = DB$ (Fig. 6.21), then which of the following gives a congruence relationship?
- $\triangle ABC \cong \triangle DBC$
 - $\triangle ABC \cong \triangle CBD$
 - $\triangle ABC \cong \triangle DCB$
 - $\triangle ABC \cong \triangle BCD$

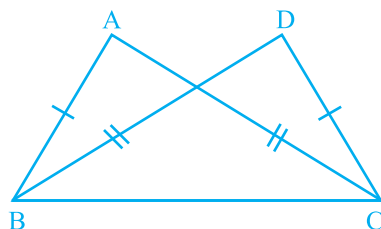

Fig. 6.21

In questions 50 to 69, fill in the blanks to make the statements true.

50. The _____ triangle always has altitude outside itself.
51. The sum of an exterior angle of a triangle and its adjacent angle is always _____.
52. The longest side of a right angled triangle is called its _____.
53. Median is also called _____ in an equilateral triangle.
54. Measures of each of the angles of an equilateral triangle is _____.
55. In an isosceles triangle, two angles are always _____.
56. In an isosceles triangle, angles opposite to equal sides are _____.
57. If one angle of a triangle is equal to the sum of other two, then the measure of that angle is _____.
58. Every triangle has at least _____ acute angle (s).
59. Two line segments are congruent, if they are of _____ lengths.
60. Two angles are said to be _____, if they have equal measures.
61. Two rectangles are congruent, if they have same _____ and _____.
62. Two squares are congruent, if they have same _____.
63. If $\triangle PQR$ and $\triangle XYZ$ are congruent under the correspondence $QPR \leftrightarrow XYZ$, then
- | | |
|--------------------------|-------------------|
| (i) $\angle R =$ _____ | (ii) $QR =$ _____ |
| (iii) $\angle P =$ _____ | (iv) $QP =$ _____ |
| (v) $\angle Q =$ _____ | (vi) $RP =$ _____ |

64. In Fig. 6.22, $\triangle PQR \cong \triangle$ _____

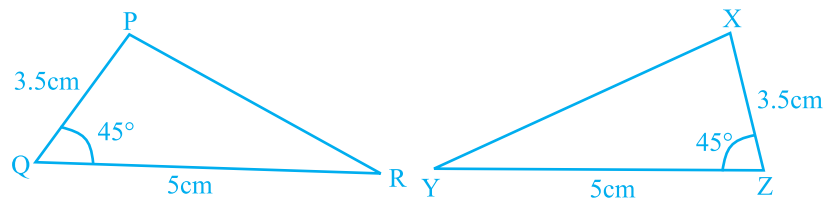

Fig. 6.22

65. In Fig. 6.23, $\triangle PQR \cong \triangle$ _____

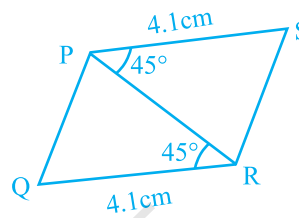

Fig. 6.23

66. In Fig. 6.24, \triangle _____ $\cong \triangle PQR$

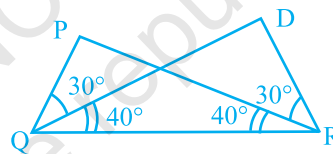

Fig. 6.24

67. In Fig. 6.25, $\triangle ARO \cong \triangle$ _____

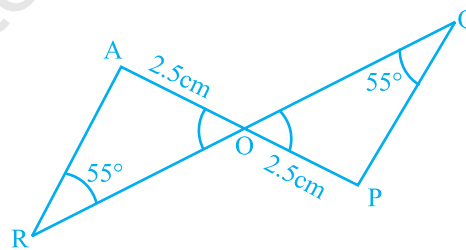

Fig. 6.25

68. In Fig. 6.26, $AB = AD$ and $\angle BAC = \angle DAC$. Then

(i) \triangle _____ $\cong \triangle ABC$.

(ii) $BC =$ _____.

(iii) $\angle BCA =$ _____ .

(iv) Line segment AC bisects _____ and _____.

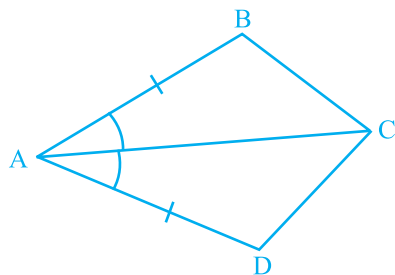

Fig. 6.26

69. In Fig. 6.27,

(i) $\angle TPQ = \angle$ _____ $+$ \angle _____

(ii) $\angle UQR = \angle$ _____ $+$ \angle _____

(iii) $\angle PRS = \angle$ _____ $+$ \angle _____

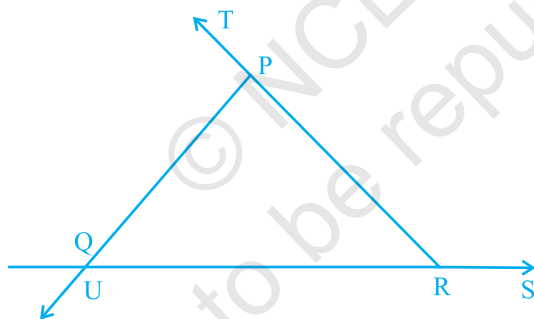

Fig. 6.27

In questions 70 to 106 state whether the statements are True or False.

70. In a triangle, sum of squares of two sides is equal to the square of the third side.
71. Sum of two sides of a triangle is greater than or equal to the third side.
72. The difference between the lengths of any two sides of a triangle is smaller than the length of third side.
73. In $\triangle ABC$, $AB = 3.5$ cm, $AC = 5$ cm, $BC = 6$ cm and in $\triangle PQR$, $PR = 3.5$ cm, $PQ = 5$ cm, $RQ = 6$ cm. Then $\triangle ABC \cong \triangle PQR$.

74. Sum of any two angles of a triangle is always greater than the third angle.
75. The sum of the measures of three angles of a triangle is greater than 180° .
76. It is possible to have a right-angled equilateral triangle.
77. If M is the mid-point of a line segment AB, then we can say that AM and MB are congruent.
78. It is possible to have a triangle in which two of the angles are right angles.
79. It is possible to have a triangle in which two of the angles are obtuse.
80. It is possible to have a triangle in which two angles are acute.
81. It is possible to have a triangle in which each angle is less than 60° .
82. It is possible to have a triangle in which each angle is greater than 60° .
83. It is possible to have a triangle in which each angle is equal to 60° .
84. A right-angled triangle may have all sides equal.
85. If two angles of a triangle are equal, the third angle is also equal to each of the other two angles.
86. In Fig. 6.28, two triangles are congruent by RHS.
87. The congruent figures super impose each other completely.
88. A one rupee coin is congruent to a five rupee coin.
89. The top and bottom faces of a kaleidoscope are congruent.
90. Two acute angles are congruent.
91. Two right angles are congruent.
92. Two figures are congruent, if they have the same shape.
93. If the areas of two squares is same, they are congruent.
94. If the areas of two rectangles are same, they are congruent.
95. If the areas of two circles are the same, they are congruent.
96. Two squares having same perimeter are congruent.
97. Two circles having same circumference are congruent.

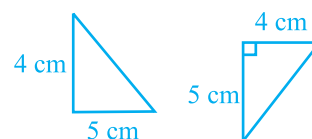

Fig. 6.28

98. If three angles of two triangles are equal, triangles are congruent.
99. If two legs of a right triangle are equal to two legs of another right triangle, then the right triangles are congruent.
100. If two sides and one angle of a triangle are equal to the two sides and angle of another triangle, then the two triangles are congruent.
101. If two triangles are congruent, then the corresponding angles are equal.
102. If two angles and a side of a triangle are equal to two angles and a side of another triangle, then the triangles are congruent.
103. If the hypotenuse of one right triangle is equal to the hypotenuse of another right triangle, then the triangles are congruent.
104. If hypotenuse and an acute angle of one right triangle are equal to the hypotenuse and an acute angle of another right triangle, then the triangles are congruent.
105. AAS congruence criterion is same as ASA congruence criterion.
106. In Fig. 6.29, $AD \perp BC$ and AD is the bisector of angle BAC . Then, $\triangle ABD \cong \triangle ACD$ by RHS.

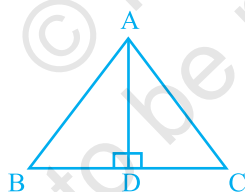

Fig. 6.29

107. The measure of three angles of a triangle are in the ratio 5 : 3 : 1. Find the measures of these angles.
108. In Fig. 6.30, find the value of x .

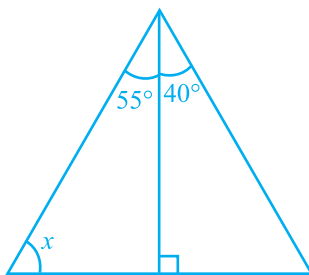

Fig. 6.30

109. In Fig. 6.31(i) and (ii), find the values of a , b and c .

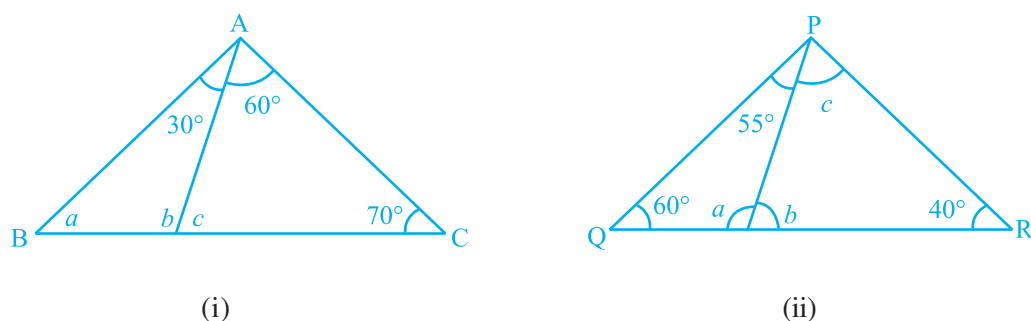

Fig. 6.31

110. In triangle XYZ, the measure of angle X is 30° greater than the measure of angle Y and angle Z is a right angle. Find the measure of $\angle Y$.
111. In a triangle ABC, the measure of angle A is 40° less than the measure of angle B and 50° less than that of angle C. Find the measure of $\angle A$.
112. I have three sides. One of my angle measures 15° . Another has a measure of 60° . What kind of a polygon am I? If I am a triangle, then what kind of triangle am I?
113. Jiya walks 6 km due east and then 8 km due north. How far is she from her starting place?
114. Jayanti takes shortest route to her home by walking diagonally across a rectangular park. The park measures 60 metres \times 80 metres. How much shorter is the route across the park than the route around its edges?



Understand the Problem

- If you write a problem in your own words, you may understand it better. Before writing a problem in your own words, you may need to read it over several times – perhaps aloud, so you can hear yourself say the words.
- Once you have written the problem in your own words, you may want to make sure you included all of the necessary information to solve the problem.

115. In $\triangle PQR$ of Fig. 6.32, $PQ = PR$. Find the measures of $\angle Q$ and $\angle R$.

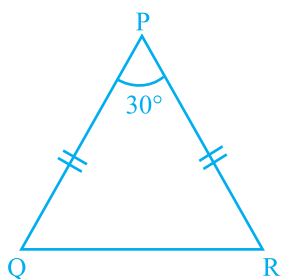

Fig. 6.32

116. In Fig. 6.33, find the measures of $\angle x$ and $\angle y$.

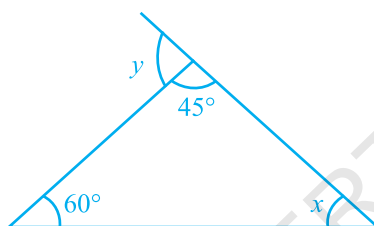

Fig. 6.33

117. In Fig. 6.34, find the measures of $\angle PON$ and $\angle NPO$.

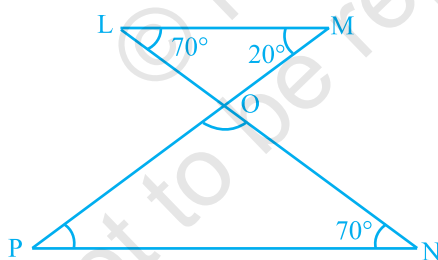

Fig. 6.34

118. In Fig. 6.35, $QP \parallel RT$. Find the values of x and y .

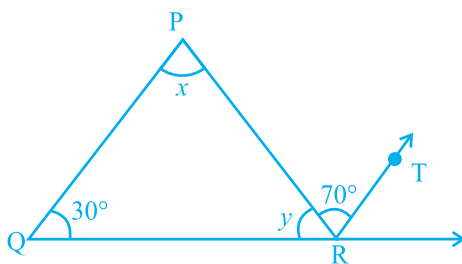

Fig. 6.35

119. Find the measure of $\angle A$ in Fig. 6.36.

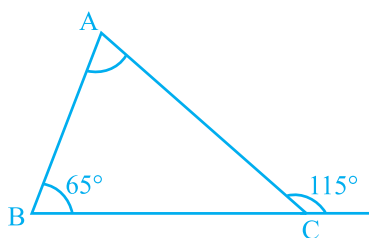

Fig. 6.36

120. In a right-angled triangle if an angle measures 35° , then find the measure of the third angle.
121. Each of the two equal angles of an isosceles triangle is four times the third angle. Find the angles of the triangle.
122. The angles of a triangle are in the ratio $2 : 3 : 5$. Find the angles.
123. If the sides of a triangle are produced in an order, show that the sum of the exterior angles so formed is 360° .
124. In $\triangle ABC$, if $\angle A = \angle C$, and exterior angle $ABX = 140^\circ$, then find the angles of the triangle.

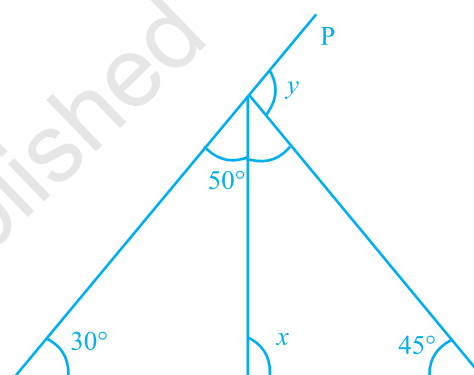

Fig. 6.37

125. Find the values of x and y in Fig. 6.37.



Plan a Strategy

- Concept maps are visual tools for organising information. A concept map shows how key concepts are related and can help you summarise and analyse information in lessons or chapters.

Create a Concept Map

- Give your concept map a title.
- Identify the main idea of your concept map.
- List the key concepts.
- Link the concepts to show the relationships between the concepts and the main idea.

126. Find the value of x in Fig. 6.38.

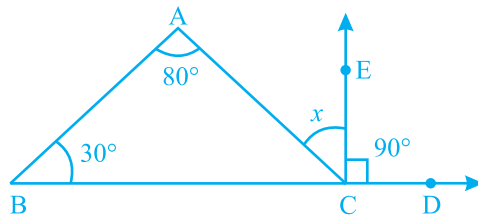

Fig. 6.38

127. The angles of a triangle are arranged in descending order of their magnitudes. If the difference between two consecutive angles is 10° , find the three angles.

128. In $\triangle ABC$, $DE \parallel BC$ (Fig. 6.39). Find the values of x , y and z .

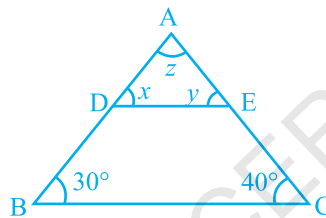

Fig. 6.39

129. In Fig. 6.40, find the values of x , y and z .

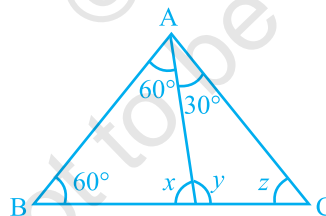

Fig. 6.40

130. If one angle of a triangle is 60° and the other two angles are in the ratio $1 : 2$, find the angles.

131. In $\triangle PQR$, if $3\angle P = 4\angle Q = 6\angle R$, calculate the angles of the triangle.

132. In $\triangle DEF$, $\angle D = 60^\circ$, $\angle E = 70^\circ$ and the bisectors of $\angle E$ and $\angle F$ meet at O . Find (i) $\angle F$ (ii) $\angle EOF$.

133. In Fig. 6.41, $\triangle PQR$ is right-angled at P . U and T are the points on line QR . If $QP \parallel ST$ and $US \parallel RP$, find $\angle S$.

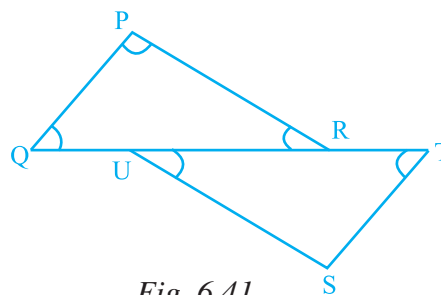
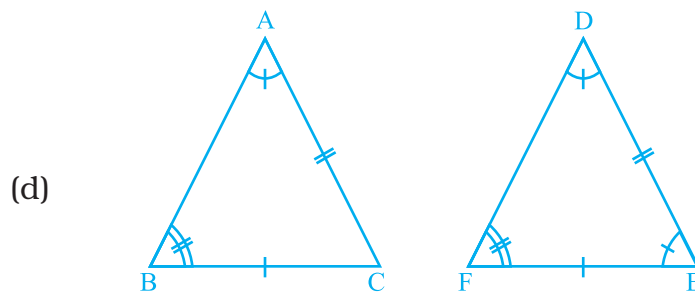
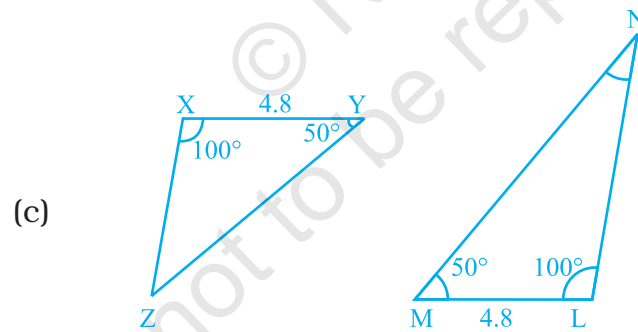
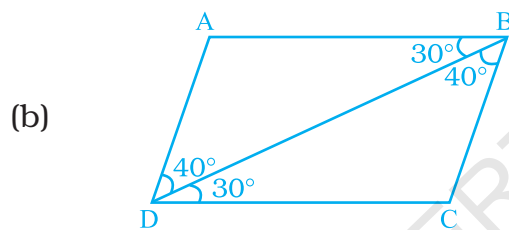
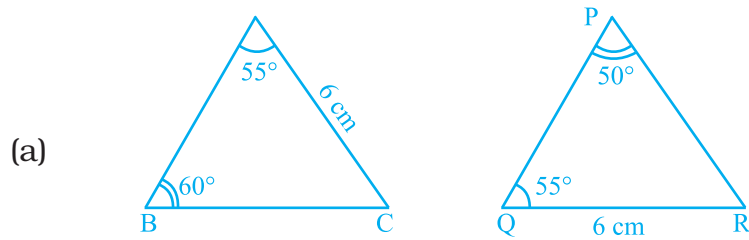

Fig. 6.41

- 134.** In each of the given pairs of triangles of Fig. 6.42, applying only ASA congruence criterion, determine which triangles are congruent. Also, write the congruent triangles in symbolic form.



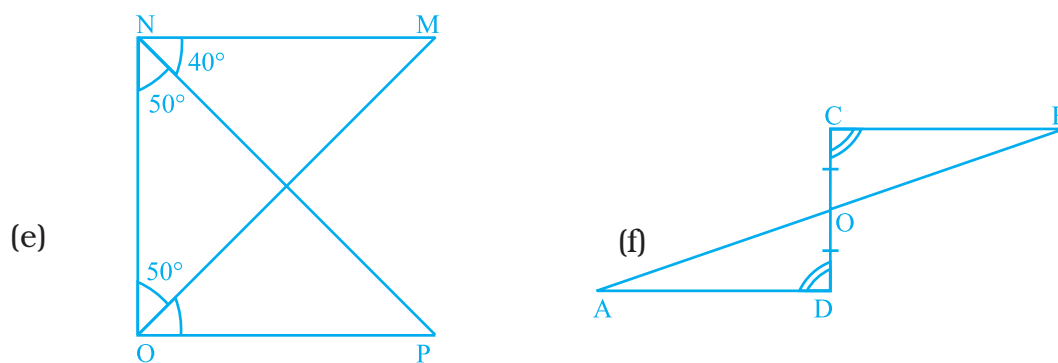
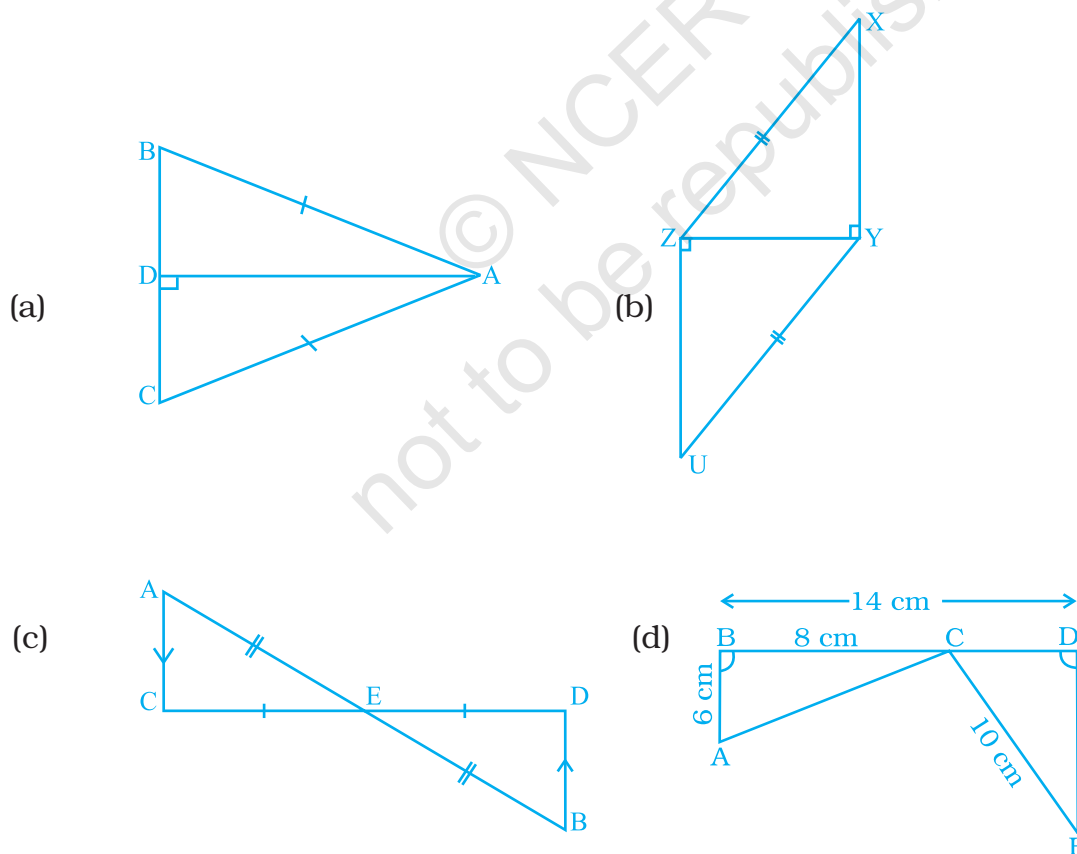

Fig. 6.42

135. In each of the given pairs of triangles of Fig. 6.43, using only RHS congruence criterion, determine which pairs of triangles are congruent. In case of congruence, write the result in symbolic form:



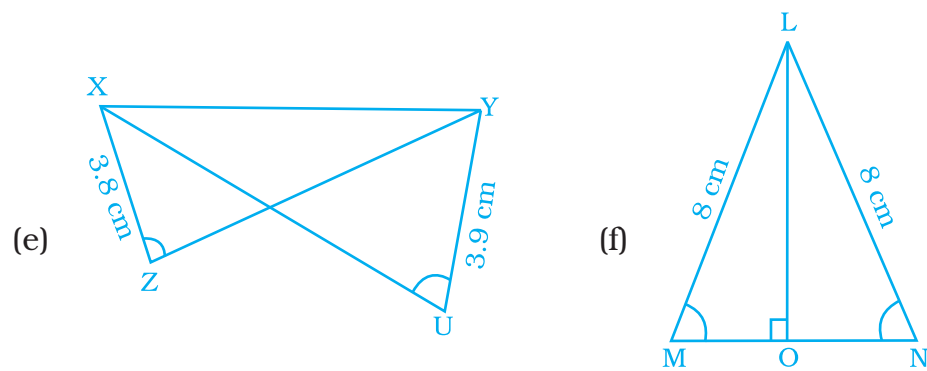

Fig. 6.43

136. In Fig. 6.44, if $RP = RQ$, find the value of x .

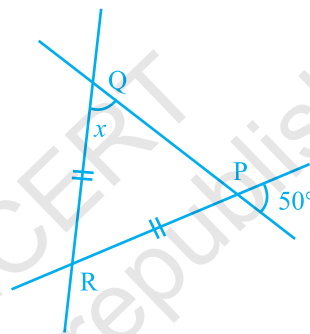

Fig. 6.44

137. In Fig. 6.45, if $ST = SU$, then find the values of x and y .

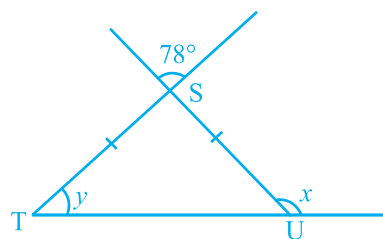

Fig. 6.45

138. Check whether the following measures (in cm) can be the sides of a right-angled triangle or not.

1.5, 3.6, 3.9

139. Height of a pole is 8 m. Find the length of rope tied with its top from a point on the ground at a distance of 6 m from its bottom.

140. In Fig. 6.46, if y is five times x , find the value of z .

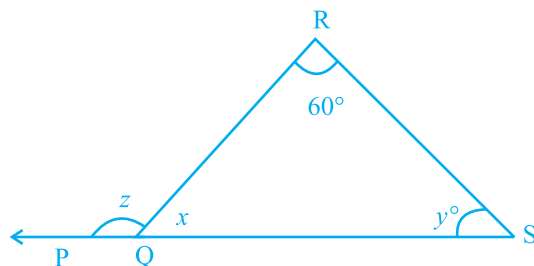
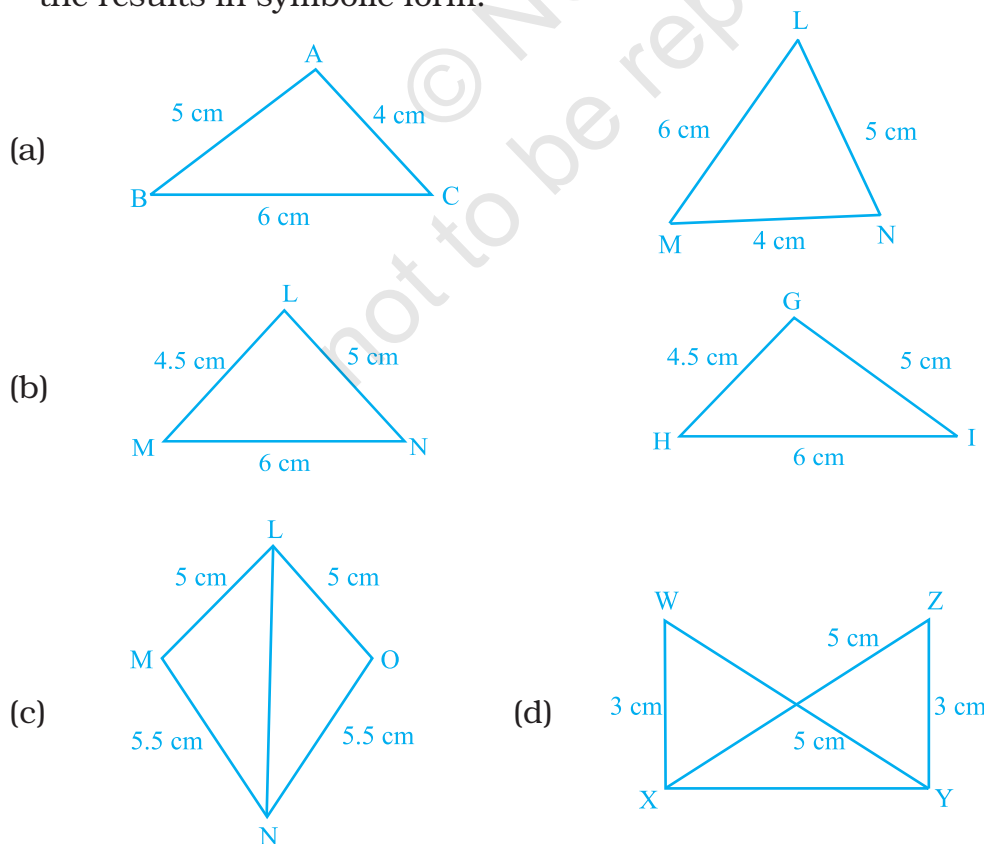

Fig. 6.46

141. The lengths of two sides of an isosceles triangle are 9 cm and 20 cm. What is the perimeter of the triangle? Give reason.
142. Without drawing the triangles write all six pairs of equal measures in each of the following pairs of congruent triangles.
- (a) $\triangle STU \cong \triangle DEF$ (b) $\triangle ABC \cong \triangle LMN$
 (c) $\triangle YZX \cong \triangle PQR$ (d) $\triangle XYZ \cong \triangle MLN$
143. In the following pairs of triangles of Fig. 6.47, the lengths of the sides are indicated along the sides. By applying SSS congruence criterion, determine which triangles are congruent. If congruent, write the results in symbolic form.



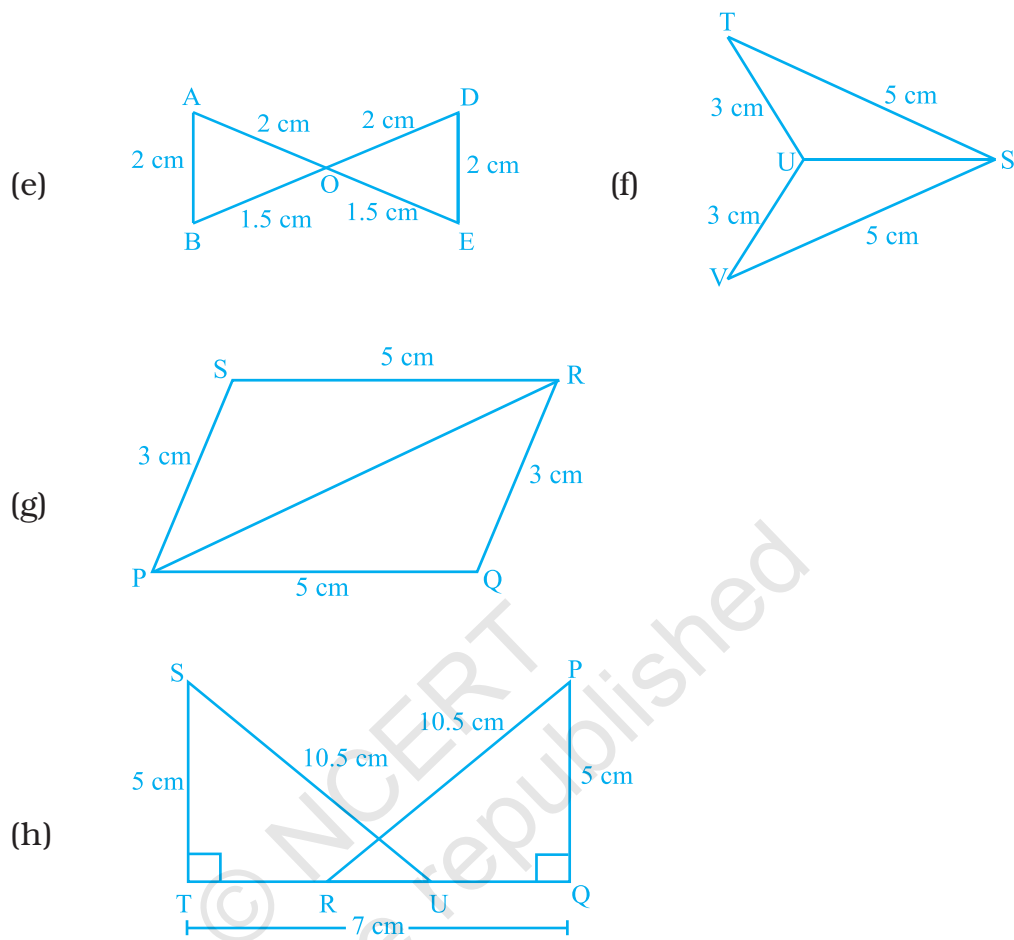

Fig. 6.47

144. ABC is an isosceles triangle with $AB = AC$ and D is the mid-point of base BC (Fig. 6.48).

- (a) State three pairs of equal parts in the triangles ABD and ACD.
- (b) Is $\triangle ABD \cong \triangle ACD$. If so why?

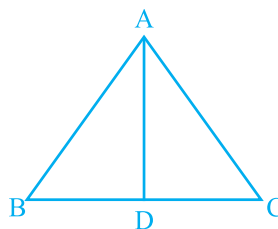

Fig. 6.48

- 145.** In Fig. 6.49, it is given that $LM = ON$ and $NL = MO$
- State the three pairs of equal parts in the triangles NOM and MLN .
 - Is $\triangle NOM \cong \triangle MLN$. Give reason?

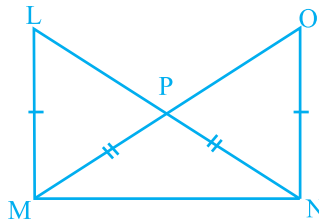
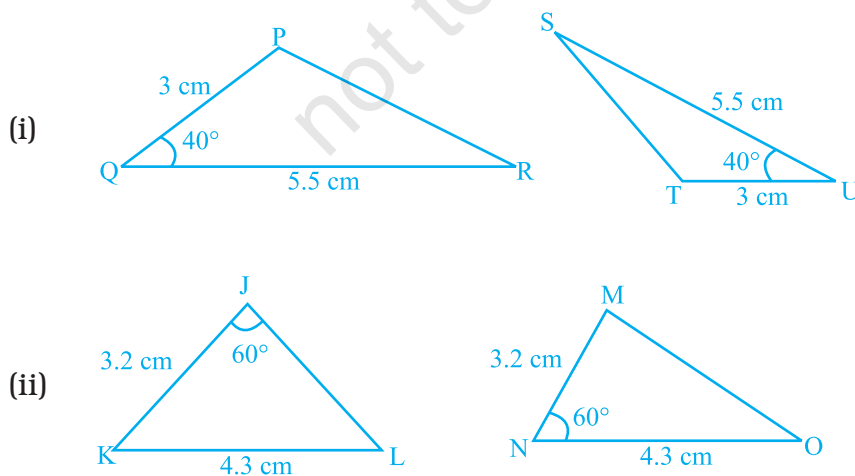
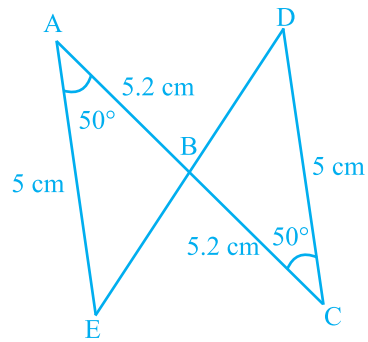

Fig. 6.49

- 146.** Triangles DEF and LMN are both isosceles with $DE = DF$ and $LM = LN$, respectively. If $DE = LM$ and $EF = MN$, then, are the two triangles congruent? Which condition do you use?
If $\angle E = 40^\circ$, what is the measure of $\angle N$?
- 147.** If $\triangle PQR$ and $\triangle SQR$ are both isosceles triangle on a common base QR such that P and S lie on the same side of QR . Are triangles PSQ and PSR congruent? Which condition do you use?
- 148.** In Fig. 6.50, which pairs of triangles are congruent by SAS congruence criterion (condition)? If congruent, write the congruence of the two triangles in symbolic form.



(iii)



(iv)

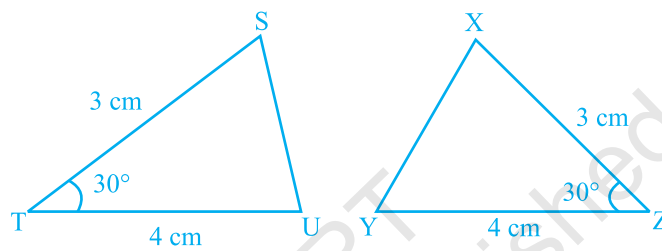

(v)

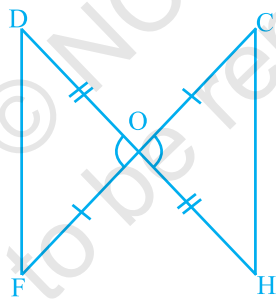

(vi)

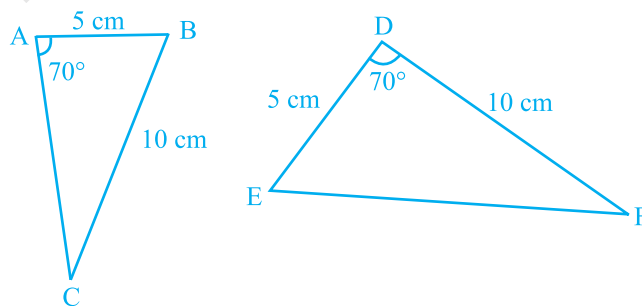

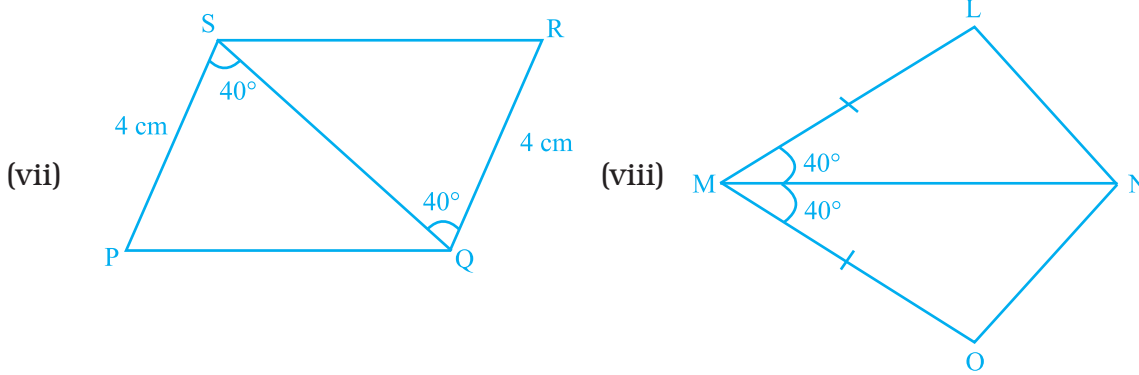

Fig. 6.50

149. State which of the following pairs of triangles are congruent. If yes, write them in symbolic form (you may draw a rough figure).

- (a) ΔPQR : $PQ = 3.5$ cm, $QR = 4.0$ cm, $\angle Q = 60^\circ$
 ΔSTU : $ST = 3.5$ cm, $TU = 4$ cm, $\angle T = 60^\circ$
- (b) ΔABC : $AB = 4.8$ cm, $\angle A = 90^\circ$, $AC = 6.8$ cm
 ΔXYZ : $YZ = 6.8$ cm, $\angle X = 90^\circ$, $ZX = 4.8$ cm

150. In Fig. 6.51, $PQ = PS$ and $\angle 1 = \angle 2$.

- (i) Is $\Delta PQR \cong \Delta PSR$? Give reasons.
- (ii) Is $QR = SR$? Give reasons.

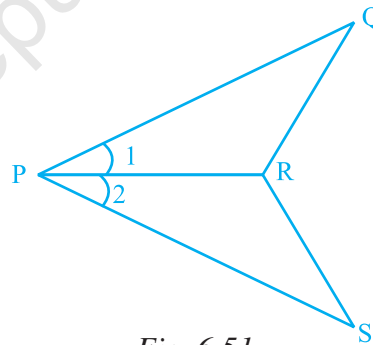

Fig. 6.51

151. In Fig. 6.52, $DE = IH$, $EG = FI$ and $\angle E = \angle I$. Is $\Delta DEF \cong \Delta HIG$? If yes, by which congruence criterion?

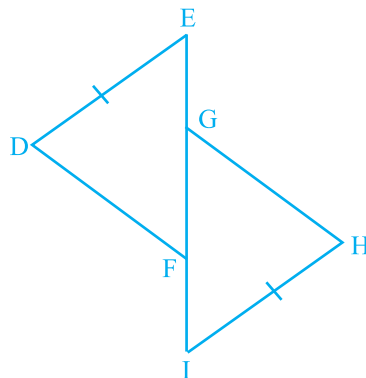

Fig. 6.52

152. In Fig. 6.53, $\angle 1 = \angle 2$ and $\angle 3 = \angle 4$.

- (i) Is $\triangle ADC \cong \triangle ABC$? Why?
- (ii) Show that $AD = AB$ and $CD = CB$.

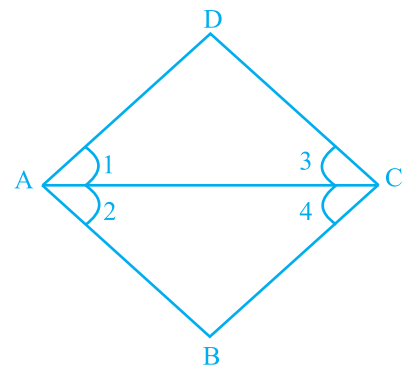

Fig. 6.53

153. Observe Fig. 6.54 and state the three pairs of equal parts in triangles ABC and DCB.

- (i) Is $\triangle ABC \cong \triangle DCB$? Why?
- (ii) Is $AB = DC$? Why?
- (iii) Is $AC = DB$? Why?

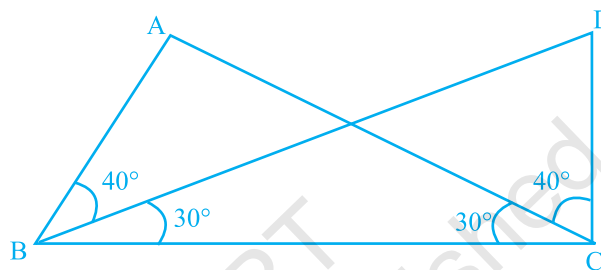

Fig. 6.54

154. In Fig. 6.55, $QS \perp PR$, $RT \perp PQ$ and $QS = RT$.

- (i) Is $\triangle QSR \cong \triangle RTQ$? Give reasons.
- (ii) Is $\angle PQR = \angle PRQ$? Give reasons.

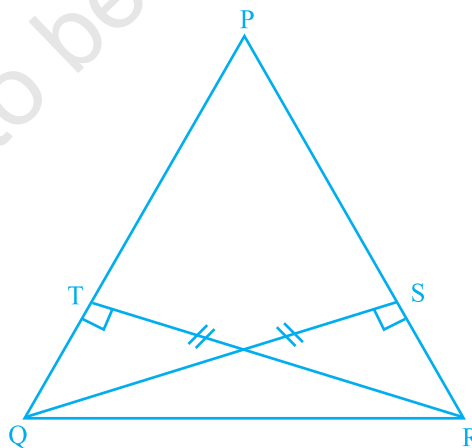

Fig. 6.55

155. Points A and B are on the opposite edges of a pond as shown in Fig. 6.56. To find the distance between the two points, the surveyor makes a right-angled triangle as shown. Find the distance AB.

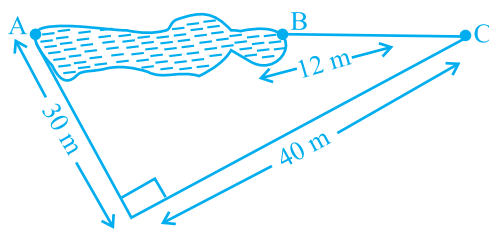

Fig. 6.56

- 156.** Two poles of 10 m and 15 m stand upright on a plane ground. If the distance between the tops is 13 m, find the distance between their feet.
- 157.** The foot of a ladder is 6 m away from its wall and its top reaches a window 8 m above the ground, (a) Find the length of the ladder. (b) If the ladder is shifted in such a way that its foot is 8 m away from the wall, to what height does its top reach?
- 158.** In Fig. 6.57, state the three pairs of equal parts in $\triangle ABC$ and $\triangle EOD$. Is $\triangle ABC \cong \triangle EOD$? Why?

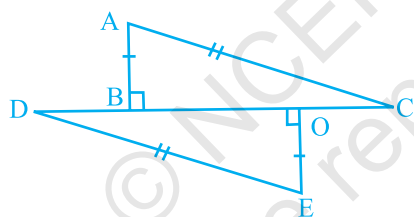

Fig. 6.57

(D) Applications

1. Draw an equilateral triangle of side 6 cm, an isosceles triangle of base 3 cm and equal sides 6 cm each and a scalene triangle of sides 3 cm, 6 cm and 7 cm. Now draw a median and an altitude in each triangle from the top vertex, measure and tabulate the lengths of all the medians and altitude's of respective triangles. What can you conclude from this activity (This activity can also be done by paper folding)?
2. Draw two triangles which have a pair of corresponding sides equal but are not congruent.
3. Draw two triangles which have two pairs of corresponding sides equal but are not congruent.

4. Draw two triangles, which have one pair of corresponding angles equal and one pair of corresponding sides equal but are not congruent.
5. Draw two triangles which have three pairs of corresponding angles equal but are not congruent.

Solve the given cross number/word and then fill up the given boxes in activities 6 and 7. Clues are given below for across as well as downward fillings. For across and downward clue numbers are written at the corner of boxes. Answers of clues have to fill up in their respective boxes.

Cross Number Puzzle 6

Across

- (a) If 6, 8, m are the sides of a right triangle, then the value of m is _____.
- (b) In $\triangle ABC$, AC is the longest side, then what can be the measure of angle B (in degree), if the three angles of triangle are 120° , 40° , 20° ?
- (c) In a right-angled triangle, one acute angle measures twice the other angle, then the smaller angle shall measure _____.
- (d) If three angles in $\triangle ABC$ are in the ratio $2 : 3 : 5$, then measure of $\angle B$ is _____.
- (e) Length of third side of a triangle whose two sides are 5 cm and 6 cm, must be less than _____.
- (f) The perimeter of $\triangle ABC$ in Fig. 6.58 is _____.

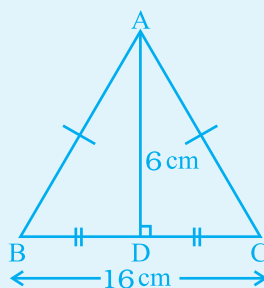

Fig. 6.58

Down

- (a) In an isosceles triangle if one of the equal angles measures 35° , then the third angle is _____.
- (b) In Fig. 6.59, the value of x is _____.

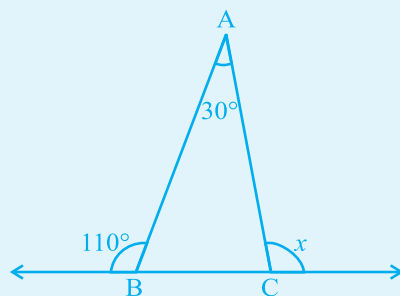
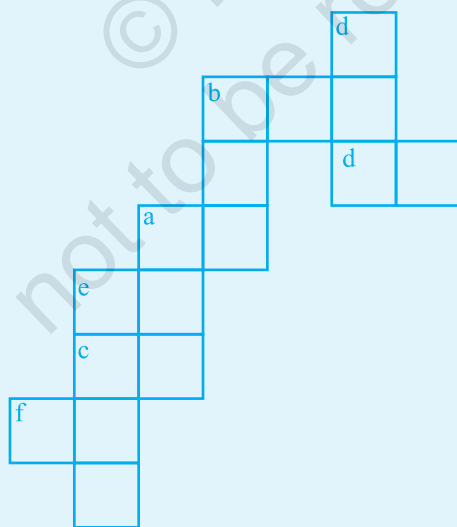

Fig. 6.59

- (c) The sum of the angles in a quadrilateral is _____.
- (d) In $\triangle ABC$, $\angle B = 80^\circ$, $\angle A = 30^\circ$, the bisectors of $\angle B$ and $\angle C$ meet at O. The measure of $\angle BOC$ is _____.



Cross Word Puzzle 7

Across

1. A triangle with all its sides unequal.
2. The longest side of a right-angled triangle.
3. Two squares having same side lengths.
4. Line segment drawn from a vertex of a triangle perpendicular to its opposite side.

Down

5. A type of triangle in which altitude falls outside the triangle.
6. A line segment joining vertex with the mid-point of the opposite side.
7. A regular triangle.
8. In a parallelogram, the line segment that divides it into two congruent triangles.

