

# Similarity (With Applications to Maps & Models)

---

## Exercise 15A

### Question 1.

In the figure, given below, straight lines AB and CD intersect at P; and  $AC \parallel BD$ . Prove that:

(i)  $\triangle APC$  and  $\triangle BPD$  are similar.

(ii) If  $BD = 2.4$  cm  $AC = 3.6$  cm,  $PD = 4.0$  cm and  $PB = 3.2$  cm; find the lengths of PA and PC.

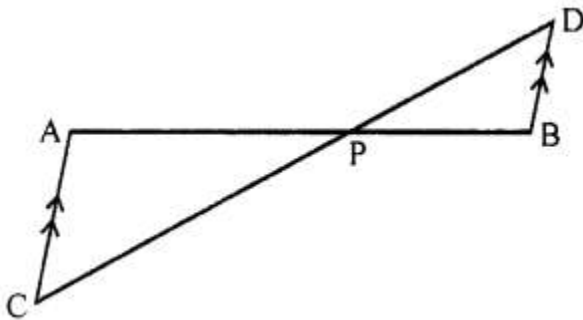

### Solution:

(i)

In  $\triangle APC$  and  $\triangle BPD$ ,

$\angle APC = \angle BPD$  .....(vertically opposite angles)

$\angle ACP = \angle BDP$  .....(alternate angles since  $AC \parallel BD$ )

$\therefore \triangle APC \sim \triangle BPD$  ....(AA criterion for similarity)

(ii)

In  $\triangle APC$  and  $\triangle BPD$ ,

$\angle APC = \angle BPD$  .....(vertically opposite angles)

$\angle ACP = \angle BDP$  .....(alternate angles since  $AC \parallel BD$ )

$\therefore \triangle APC \sim \triangle BPD$  ....(AA criterion for similarity)

$$\text{So, } \frac{PA}{PB} = \frac{PC}{PD} = \frac{AC}{BD}$$

$$\Rightarrow \frac{PA}{3.2} = \frac{PC}{4} = \frac{3.6}{2.4}$$

$$\text{So, } \frac{PA}{3.2} = \frac{3.6}{2.4} \text{ and } \frac{PC}{4} = \frac{3.6}{2.4}$$

$$\Rightarrow PA = \frac{3.6 \times 3.2}{2.4} = 4.8 \text{ cm}$$

$$\text{and } PC = \frac{3.6 \times 4}{2.4} = 6 \text{ cm}$$

Hence,  $PA = 4.8 \text{ cm}$  and  $PC = 6 \text{ cm}$ .

### Question 2.

In a trapezium ABCD, side AB is parallel to side DC; and the diagonals AC and BD intersect each other at point P. Prove that:

(i)  $\triangle APB$  is similar to  $\triangle CPD$

(ii)  $PA \times PD = PB \times PC$

**Solution:**

(i)

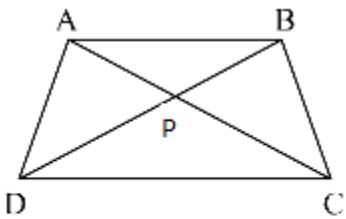

In  $\triangle APB$  and  $\triangle CPD$ ,

$\angle APB = \angle CPD$  .....(vertically opposite angles)

$\angle ABP = \angle CDP$  .....(alternate angles since  $AB \parallel DC$ )

$\therefore \triangle APB \sim \triangle CPD$  ....(AA criterion for similarity)

(ii)

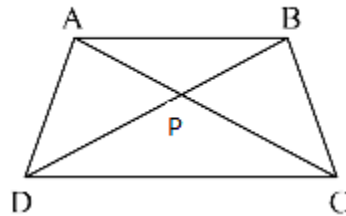

In  $\triangle APB$  and  $\triangle CPD$ ,

$\angle APB = \angle CPD$  .....(vertically opposite angles)

$\angle ABP = \angle CDP$  .....(alternate angles since  $AB \parallel DC$ )

$\therefore \triangle APB \sim \triangle CPD$  ....(AA criterion for similarity)

$\Rightarrow \frac{PA}{PC} = \frac{PB}{PD}$  .....(Since corresponding sides of similar triangles are equal.)

$\Rightarrow PA \times PD = PB \times PC$

### Question 3.

P is a point on side BC of a parallelogram ABCD. If DP produced meets AB produced at point L, prove that:

(i)  $DP: PL = DC: BL$ .

(ii)  $DL: DP = AL: DC$ .

**Solution:**

(i)

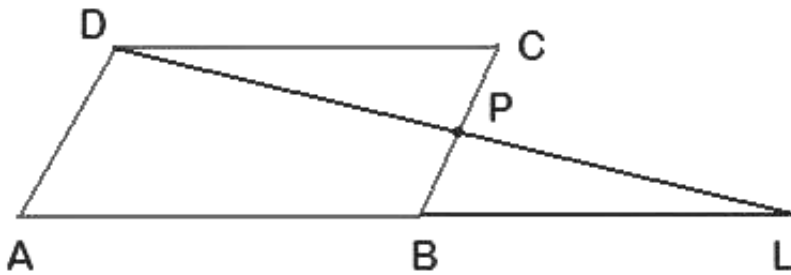

Since  $AD \parallel BC$ , that is,  $AD \parallel BP$ ,

by the Basic Proportionality theorem, we get

$$\frac{DL}{DP} = \frac{AL}{AB}$$

Since ABCD is a parallelogram,  $AB = DC$ .

So,  $\frac{DL}{DP} = \frac{AL}{DC}$ .

(ii)

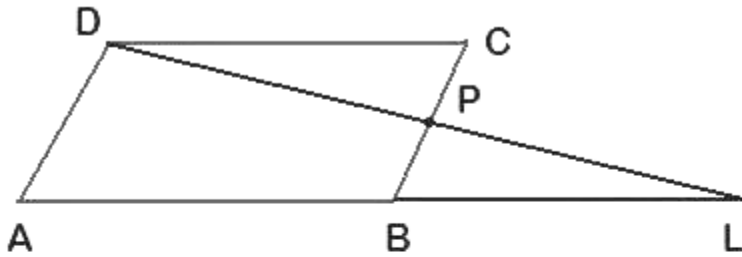

Since  $AD \parallel BC$ , that is,  $AD \parallel BP$ ,  
by the Basic Proportionality theorem, we get

$$\frac{DP}{PL} = \frac{AB}{BL}$$

Since ABCD is a parallelogram,  $AB = DC$ .

$$\text{So, } \frac{DP}{PL} = \frac{DC}{BL}.$$

**Question 4.**

In quadrilateral ABCD, the diagonals AC and BD intersect each other at point O. If  $AO = 2CO$  and  $BO = 2DO$ ; show that:

- (i)  $\triangle AOB$  is similar to  $\triangle COD$ .
- (ii)  $OA \times OD = OB \times OC$ .

**Solution:**

(i)

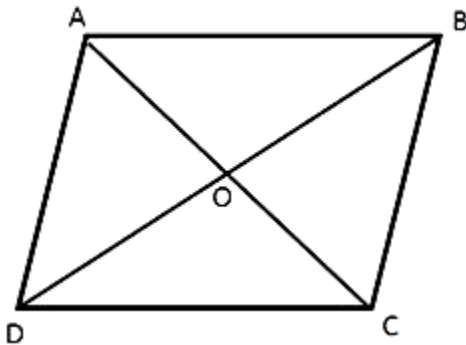

Since  $AO = 2CO$  and  $BO = 2DO$ ,

$$\frac{AO}{CO} = \frac{2}{1} = \frac{BO}{DO}$$

Also,  $\angle AOB = \angle DOC$  ....(vertically opposite angles)

So,  $\triangle AOB \sim \triangle COD$  ....(SAS criterion for similarity)

(ii)

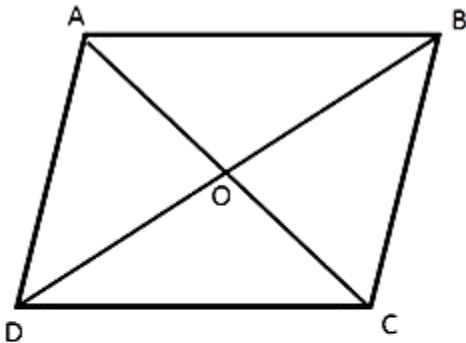

Since  $AO = 2CO$  and  $BO = 2DO$ ,

$$\frac{AO}{CO} = \frac{2}{1} = \frac{BO}{DO}$$

So,  $OA \times OD = OB \times OC$ .

**Question 5.**

In  $\triangle ABC$ , angle  $ABC$  is equal to twice the angle  $ACB$ , and bisector of angle  $ABC$  meets the opposite side at point  $P$ . Show that:

(i)  $CB : BA = CP : PA$

(ii)  $AB \times BC = BP \times CA$

**Solution:**

(i)

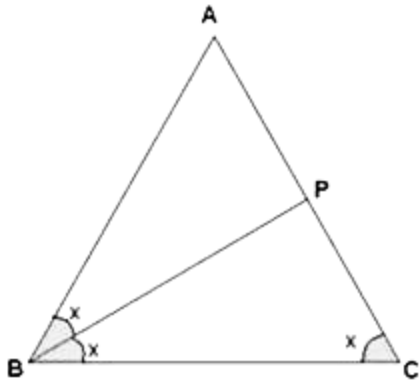

In  $\triangle ABC$ ,

$$\angle ABC = 2\angle ACB$$

Let  $\angle ACB = x$

$$\Rightarrow \angle ABC = 2\angle ACB = 2x$$

Given BP is bisector of  $\angle ABC$ .

Hence  $\angle ABP = \angle PBC = x$ .

Using the angle bisector theorem,

that is, the bisector of an angle divides the side opposite to it in the ratio of other two sides.

Hence,  $CB : BA = CP : PA$ .

(ii)

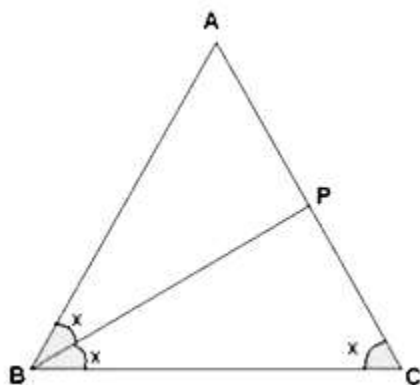

In  $\triangle ABC$ ,

$$\angle ABC = 2\angle ACB$$

Let  $\angle ACB = x$

$$\Rightarrow \angle ABC = 2\angle ACB = 2x$$

Given BP is bisector of  $\angle ABC$ .

Hence  $\angle ABP = \angle PBC = x$ .

Using the angle bisector theorem,

that is, the bisector of an angle divides the side opposite to it in the ratio of other two sides.

Hence,  $CB : BA = CP : PA$ .

Consider  $\triangle ABC$  and  $\triangle APB$ ,

$$\angle ABC = \angle APB \dots [\text{Exterior angle property}]$$

$$\angle BCP = \angle ABP \dots [\text{Given}]$$

$\therefore \triangle ABC \sim \triangle APB$  [AA criterion for Similarity]

$$\frac{CA}{AB} = \frac{BC}{BP} \dots (\text{Corresponding sides of similar triangles are proportional.})$$

$$\Rightarrow AB \times BC = BP \times CA$$

### Question 6.

In  $\triangle ABC$ ;  $BM \perp AC$  and  $CN \perp AB$ ; show that:

$$\frac{AB}{AC} = \frac{BM}{CN} = \frac{AM}{AN}$$

**Solution:**

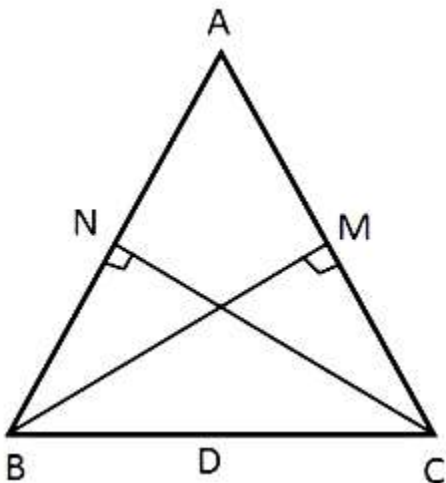

In  $\triangle ABM$  and  $\triangle ACN$ ,  
 $\angle AMB = \angle ANC$  ....( $BM \perp AC$  and  $CN \perp AB$ )  
 $\angle BAM = \angle CAN$  ....(common angle)  
 $\Rightarrow \triangle ABM \sim \triangle ACN$  ....(AA criterion for Similarity)  
 $\Rightarrow \frac{AB}{AC} = \frac{BM}{CN} = \frac{AM}{AN}$

**Question 7.**

In the given figure,  $DE \parallel BC$ ,  $AE = 15$  cm,  $EC = 9$  cm,  $NC = 6$  cm and  $BN = 24$  cm.

- (i) Write all possible pairs of similar triangles.
- (ii) Find lengths of  $ME$  and  $DM$ .

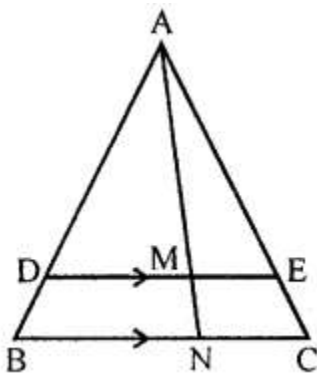

**Solution:**

(i)

In  $\triangle AME$  and  $\triangle ANC$ ,  
 $\angle AME = \angle ANC$  ....(Since  $DE \parallel BC$  that is,  $ME \parallel NC$ .)  
 $\angle MAE = \angle NAC$  ....(common angle)  
 $\Rightarrow \triangle AME \sim \triangle ANC$  ....(AA criterion for Similarity)

In  $\triangle ADM$  and  $\triangle ABN$ ,  
 $\angle ADM = \angle ABN$  ....(Since  $DE \parallel BC$  that is,  $DM \parallel BN$ .)  
 $\angle DAM = \angle BAN$  ....(common angle)  
 $\Rightarrow \triangle ADM \sim \triangle ABN$  ....(AA criterion for Similarity)

In  $\triangle ADE$  and  $\triangle ABC$ ,  
 $\angle ADE = \angle ABC$  ....(Since  $DE \parallel BC$  that is,  $ME \parallel NC$ .)  
 $\angle AED = \angle ACB$  ....(Since  $DE \parallel BC$ .)  
 $\Rightarrow \triangle ADE \sim \triangle ABC$  ....(AA criterion for Similarity)



(ii)

In  $\triangle AME$  and  $\triangle ANC$ ,  
 $\angle AME = \angle ANC$  ....(Since  $DE \parallel BC$  that is,  $ME \parallel NC$ .)  
 $\angle MAE = \angle NAC$  .....(common angle)  
 $\Rightarrow \triangle AME \sim \triangle ANC$  ....(AA criterion for Similarity)  
 $\Rightarrow \frac{ME}{NC} = \frac{AE}{AC}$   
 $\Rightarrow \frac{ME}{6} = \frac{15}{24}$   
 $\Rightarrow ME = 3.75$  cm

In  $\triangle ADE$  and  $\triangle ABC$ ,  
 $\angle ADE = \angle ABC$  ....(Since  $DE \parallel BC$  that is,  $ME \parallel NC$ .)  
 $\angle AED = \angle ACB$  ....(Since  $DE \parallel BC$ .)  
 $\Rightarrow \triangle ADE \sim \triangle ABC$  ....(AA criterion for Similarity)  
 $\Rightarrow \frac{AD}{AB} = \frac{AE}{AC} = \frac{15}{24}$  .....(i)

In  $\triangle ADM$  and  $\triangle ABN$ ,  
 $\angle ADM = \angle ABN$  ....(Since  $DE \parallel BC$  that is,  $DM \parallel BN$ .)  
 $\angle DAM = \angle BAN$  ....(common angle)  
 $\Rightarrow \triangle ADM \sim \triangle ABN$  ....(AA criterion for Similarity)  
 $\Rightarrow \frac{DM}{BN} = \frac{AD}{AB} = \frac{15}{24}$  ....(from (i))  
 $\Rightarrow \frac{DM}{24} = \frac{15}{24}$   
 $\Rightarrow DM = 15$  cm

### Question 8.

In the given figure,  $AD = AE$  and  $AD^2 = BD \times EC$   
Prove that: triangles  $ABD$  and  $CAE$  are similar.

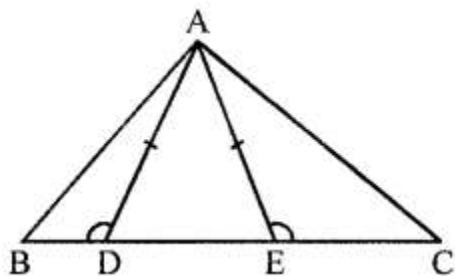

**Solution:**

In  $\triangle ABD$  and  $\triangle CAE$ ,  
 $\angle ADE = \angle AED$  ....(Angles opposite equal sides are equal.)  
 So,  $\angle ADB = \angle AEC$   
 ....(Since  $\angle ADB + \angle ADE = 180^\circ$  and  $\angle AEC + \angle AED = 180^\circ$ )  
 Also,  $AD^2 = BD \times EC$   
 $\Rightarrow \frac{AD}{BD} = \frac{EC}{AD}$   
 $\Rightarrow \frac{AD}{BD} = \frac{EC}{AE}$   
 $\Rightarrow \triangle ABD \sim \triangle CAE$  ....(SAS criterion for Similarity)

**Question 9.**

In the given figure,  $AB \parallel DC$ ,  $BO = 6$  cm and  $DQ = 8$  cm; find:  $BP \times DO$ .

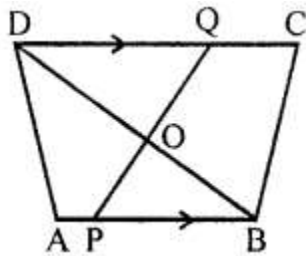
**Solution:**

In  $\triangle DOQ$  and  $\triangle BOP$ ,  
 $\angle QDO = \angle PBO$  ....(Since  $AB \parallel DC$  that is,  $PB \parallel DQ$ .)  
 So,  $\angle DOQ = \angle BOP$  ....(vertically opposite angles)  
 $\Rightarrow \triangle DOQ \sim \triangle BOP$  ....(AA criterion for Similarity)  
 $\Rightarrow \frac{DO}{BO} = \frac{DQ}{BP}$   
 $\Rightarrow \frac{DO}{6} = \frac{8}{BP}$   
 $\Rightarrow BP \times DO = 48 \text{ cm}^2$

**Question 10.**

Angle  $BAC$  of triangle  $ABC$  is obtuse and  $AB = AC$ .  $P$  is a point in  $BC$  such that  $PC = 12$  cm.  $PQ$  and  $PR$  are perpendiculars to sides  $AB$  and  $AC$  respectively. If  $PQ = 15$  cm and

PR=9 cm; find the length of PB

**Solution:**

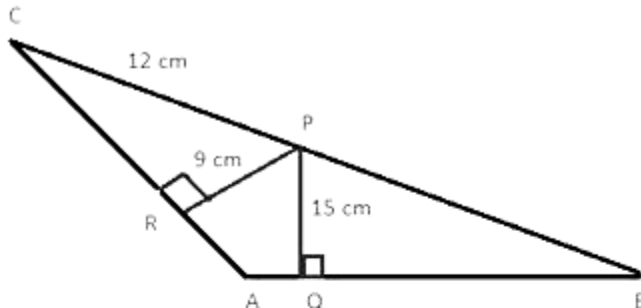

In  $\triangle ABC$ ,

$AC = AB$  ....(Given)

$\Rightarrow \angle ABC = \angle ACB$  ....(Angles opposite equal sides are equal.)

In  $\triangle PRC$  and  $\triangle PQB$ ,

$\angle ABC = \angle ACB$

$\angle PRC = \angle PQB$  ....(Both are right angles.)

$\Rightarrow \triangle PRC \sim \triangle PQB$  .....(AA criterion for Similarity)

$$\Rightarrow \frac{PR}{PQ} = \frac{RC}{QB} = \frac{PC}{PB}$$

$$\Rightarrow \frac{PR}{PQ} = \frac{PC}{PB}$$

$$\Rightarrow \frac{9}{15} = \frac{12}{PB}$$

$$\Rightarrow PB = 20 \text{ cm}$$

**Question 11.**

State, true or false:

- (i) Two similar polygons are necessarily congruent.
- (ii) Two congruent polygons are necessarily similar.
- (iii) All equiangular triangles are similar.
- (iv) All isosceles triangles are similar.
- (v) Two isosceles-right triangles are similar.
- (vi) Two isosceles triangles are similar, if an angle of one is congruent to the corresponding angle of the other.
- (vii) The diagonals of a trapezium, divide each other into proportional segments.

**Solution:**

- (i) False
- (ii) True
- (iii) True
- (iv) False
- (v) True
- (vi) True
- (vii) True

**Question 12.**

Given  $\angle GHE = \angle DFE = 90^\circ$ ,  $DH = 8$ ,  $DF = 12$ ,  $DG = 3x + 1$  and  $DE = 4x + 2$ .

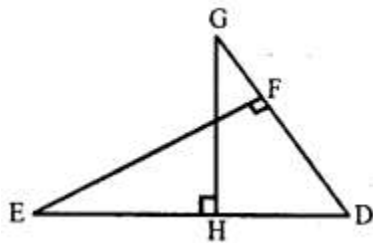

Find; the lengths of segments DG and DE.

**Solution:**

In  $\triangle DHG$  and  $\triangle DFE$ ,  
 $\angle GHD = \angle DFE = 90^\circ$   
 $\angle D = \angle D$  (Common)  
 $\therefore \triangle DHG \sim \triangle DFE$

$$\Rightarrow \frac{DH}{DF} = \frac{DG}{DE}$$

$$\Rightarrow \frac{8}{12} = \frac{3x - 1}{4x + 2}$$

$$\Rightarrow 32x + 16 = 36x - 12$$

$$\Rightarrow 28 = 4x$$

$$\Rightarrow x = 7$$

$$\therefore DG = 3 \times 7 - 1 = 20$$

$$DE = 4 \times 7 + 2 = 30$$

**Question 13.**

D is a point on the side BC of triangle ABC such that angle ADC is equal to angle BAC. Prove that  $CA^2 = CB \times CD$ .

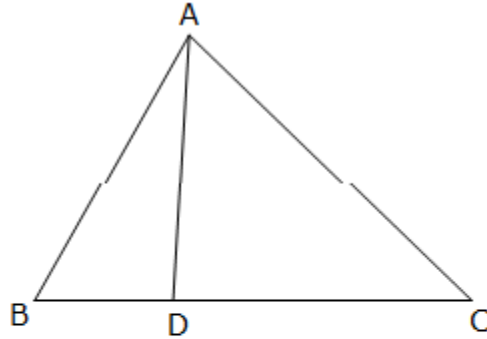
**Solution:**

In  $\triangle ADC$  and  $\triangle ABC$ ,  
 $\angle ADC = \angle BAC$  (Given)  
 $\angle ACD = \angle ACB$  (Common)  
 $\therefore \triangle ADC \sim \triangle ABC$   
 $\therefore \frac{CA}{CB} = \frac{CD}{CA}$   
Hence,  $CA^2 = CB \times CD$

**Question 14.**

In the given figure,  $\triangle ABC$  and  $\triangle AMP$  are right angled at B and M respectively. Given AC = 10 cm, AP = 15 cm and PM = 12 cm.

- (i) Prove that  $\triangle ABC \sim \triangle AMP$
- (ii) Find AB and BC.

**Solution:**

(i) In  $\triangle ABC$  and  $\triangle AMP$ ,  
 $\angle BAC = \angle PAM$  [Common]  
 $\angle ABC = \angle PMA$  [Each =  $90^\circ$ ]  
 $\triangle ABC \sim \triangle AMP$  [AA Similarity]  
(ii)  
 $AM = \sqrt{AP^2 - PM^2} = \sqrt{15^2 - 12^2} = 11$   
Since  $\triangle ABC \sim \triangle AMP$ ,

$$\frac{AB}{AM} = \frac{BC}{PM} = \frac{AC}{AP}$$

$$\Rightarrow \frac{AB}{AM} = \frac{BC}{PM} = \frac{AC}{AP}$$

$$\Rightarrow \frac{AB}{11} = \frac{BC}{12} = \frac{10}{15}$$

From this we can write,

$$\frac{AB}{11} = \frac{10}{15}$$

$$\Rightarrow AB = \frac{10 \times 11}{15} = 7.33$$

$$\frac{BC}{12} = \frac{10}{15}$$

$$\Rightarrow BC = 8 \text{ cm}$$

**Question 15.**

Given : RS and PT are altitudes of  $\triangle PQR$  prove that:

(i)  $\triangle PQT \sim \triangle QRS$ ,

(ii)  $PQ \times QS = RQ \times QT$ .

**Solution:**

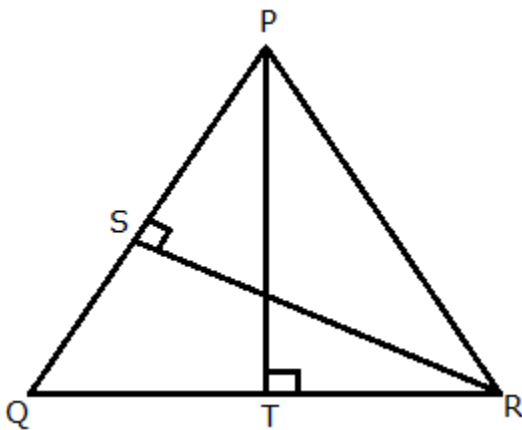

(i)

In  $\triangle PQT$  and  $\triangle QRS$ ,

$$\angle PTQ = \angle RSQ = 90^\circ \text{ (Given)}$$

$$\angle PQT = \angle RQS \quad \text{(Common)}$$

$$\triangle PQT \sim \triangle RQS \quad \text{(By AA similarity)}$$

(ii)

Since, triangles PQT and RQS are similar.

$$\therefore \frac{PQ}{RQ} = \frac{QT}{QS}$$

$$\Rightarrow PQ \times QS = RQ \times QT$$

### Question 16.

Given : ABCD is a rhombus, DPR and CBR are straight lines

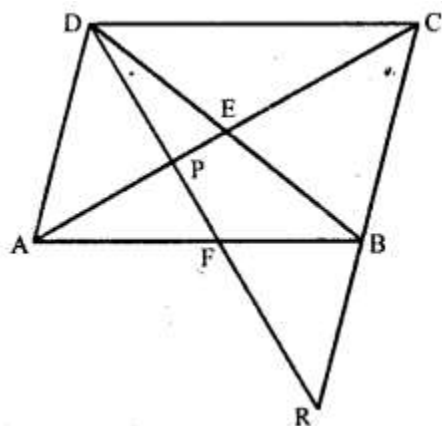

Prove that:  $DP \times CR = DC \times PR$ .

### Solution:

In  $\triangle DPA$  and  $\triangle RPC$ ,

$$\angle DPA = \angle RPC \quad \text{(Vertically opposite angles)}$$

$$\angle PAD = \angle PCR \quad \text{(Alternate angles)}$$

$$\triangle DPA \sim \triangle RPC$$

$$\therefore \frac{DP}{PR} = \frac{AD}{CR}$$

$$\frac{DP}{PR} = \frac{DC}{CR} \quad \text{(AD = DC, as ABCD is rhombus)}$$

Hence,  $DP \times CR = DC \times PR$

**Question 17.**

Given:  $FB = FD$ ,  $AE \perp FD$  and  $FC \perp AD$ . Prove:  $\frac{FB}{AD} = \frac{BC}{ED}$

**Solution:**

Given,  $FB = FD$

$$\therefore \angle FDB = \angle FBD \quad \dots (1)$$

In  $\triangle AED$  and  $\triangle FCB$ ,

$$\angle AED = \angle FCB = 90^\circ$$

$$\angle ADE = \angle FBC \quad \text{[Using (1)]}$$

$$\triangle AED \sim \triangle FCB \quad \text{[By AA similarity]}$$

$$\therefore \frac{AD}{FB} = \frac{ED}{BC}$$

$$\frac{FB}{AD} = \frac{BC}{ED}$$

**Question 18.**

In  $\triangle PQR$ ,  $\angle Q = 90^\circ$  and  $QM$  is perpendicular to  $PR$ , Prove that:

- (i)  $PQ^2 = PM \times PR$
- (ii)  $QR^2 = PR \times MR$
- (iii)  $PQ^2 + QR^2 = PR^2$

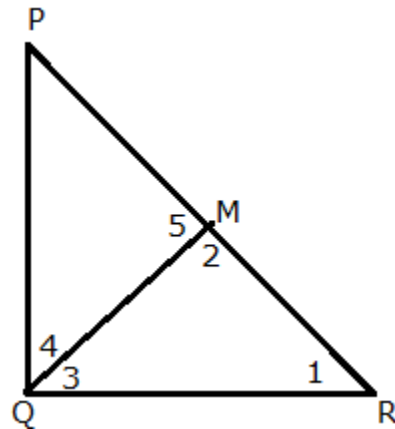
**Solution:**



(i) In  $\triangle PQM$  and  $\triangle PQR$ ,

$$\angle PMQ = \angle PQR = 90^\circ$$

$$\angle QPM = \angle RPQ \text{ (Common)}$$

$\therefore \triangle PQM \sim \triangle PRQ$  (By AA similarity)

$$\therefore \frac{PQ}{PR} = \frac{PM}{PQ}$$

$$\Rightarrow PQ^2 = PM \times PR$$

(ii) In  $\triangle QMR$  and  $\triangle PQR$ ,

$$\angle QMR = \angle PQR = 90^\circ$$

$$\angle QRM = \angle QRP \text{ (Common)}$$

$\therefore \triangle QMR \sim \triangle PQR$  (By AA similarity)

$$\therefore \frac{QR}{PR} = \frac{MR}{QR}$$

$$\Rightarrow QR^2 = PR \times MR$$

(iii) Adding the relations obtained in (i) and (ii), we get,

$$PQ^2 + QR^2 = PM \times PR + PR \times MR$$

$$= PR(PM + MR)$$

$$= PR \times PR$$

$$= PR^2$$

### Question 19.

In  $\triangle ABC$ ,  $\angle B = 90^\circ$  and  $BD \perp AC$ .

(i) If  $CD = 10$  cm and  $BD = 8$  cm; find  $AD$ .

(ii) If  $AC = 18$  cm and  $AD = 6$  cm; find  $BD$ .

(iii) If  $AC = 9$  cm,  $AB = 7$  cm; find  $AD$ .

**Solution:**

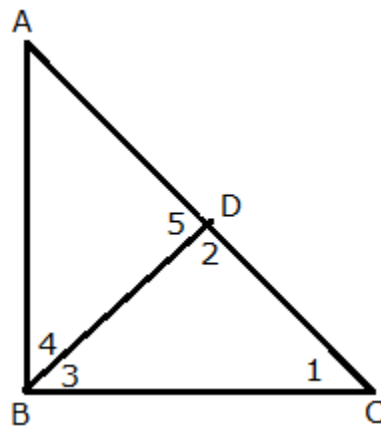

(i) In  $\triangle CDB$ ,

$$\angle 1 + \angle 2 + \angle 3 = 180^\circ$$

$$\angle 1 + \angle 3 = 90^\circ \dots (1) \text{ (Since, } \angle 2 = 90^\circ \text{)}$$

$$\angle 3 + \angle 4 = 90^\circ \dots (2) \text{ (Since, } \angle ABC = 90^\circ \text{)}$$

From (1) and (2),

$$\angle 1 + \angle 3 = \angle 3 + \angle 4$$

$$\angle 1 = \angle 4$$

Also,  $\angle 2 = \angle 5 = 90^\circ$

$\therefore \triangle CDB \sim \triangle BDA$  (By AA similarity)

$$\Rightarrow \frac{CD}{BD} = \frac{BD}{AD}$$

$$\Rightarrow BD^2 = AD \times CD$$

$$\Rightarrow (8)^2 = AD \times 10$$

$$\Rightarrow AD = 6.4$$

Hence,  $AD = 6.4$  cm

(ii) Also, by similarity, we have :

$$\frac{BD}{DA} = \frac{CD}{BD}$$

$$BD^2 = 6 \times (18 - 6)$$

$$BD^2 = 72$$

Hence,  $BD = 8.5$  cm

(iii)

Clearly,  $\triangle ADB \sim \triangle ABC$

$$\therefore \frac{AD}{AB} = \frac{AB}{AC}$$

$$AD = \frac{7 \times 7}{9} = \frac{49}{9} = 5\frac{4}{9}$$

Hence,  $AD = 5\frac{4}{9}$  cm

### Question 20.

In the figure, PQRS is a parallelogram with  $PQ = 16$  cm and  $QR = 10$  cm. L is a point on PR such that  $RL : LP = 2 : 3$ . QL produced meets RS at M and PS produced at N.

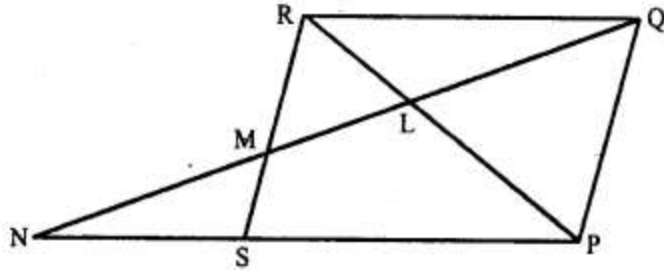

Find the lengths of PN and RM.

**Solution:**

In  $\triangle RLQ$  and  $\triangle PLN$ ,

$\angle RLQ = \angle PLN$  (Vertically opposite angles)

$\angle LRQ = \angle LPN$  (Alternate angles)

$\triangle RLQ \sim \triangle PLN$  (AA similarity)

$$\therefore \frac{RL}{LP} = \frac{RQ}{PN}$$

$$\frac{2}{3} = \frac{10}{PN}$$

$$PN = 15 \text{ cm}$$

In  $\triangle RLM$  and  $\triangle PLQ$ ,

$\angle RLM = \angle PLQ$  (Vertically opposite angles)

$\angle LRM = \angle LPQ$  (Alternate angles)

$\triangle RLM \sim \triangle PLQ$  (AA similarity)

$$\therefore \frac{RM}{PQ} = \frac{RL}{LP}$$

$$\frac{RM}{16} = \frac{2}{3}$$

$$RM = \frac{32}{3} = 10\frac{2}{3} \text{ cm}$$

**Question 21.**

In quadrilateral ABCD, diagonals AC and BD intersect at point E. Such that

$$AE : EC = BE : ED.$$

Show that ABCD is a parallelogram

**Solution:**

Given,  $AE: EC = BE: ED$

Draw  $EF \parallel AB$

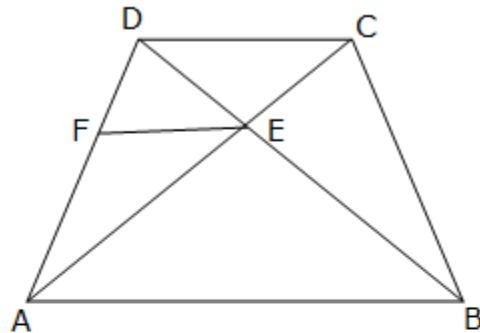

In  $\triangle ABD$ ,  $EF \parallel AB$

Using Basic Proportionality theorem,

$$\frac{DF}{FA} = \frac{DE}{EB}$$

But, given  $\frac{DE}{EB} = \frac{CE}{EA}$

$$\therefore \frac{DF}{FA} = \frac{CE}{EA}$$

Thus, in  $\triangle DCA$ , E and F are points on CA and DA respectively such that  $\frac{DF}{FA} = \frac{CE}{EA}$

Thus, by converse of Basic proportionality theorem,  $FE \parallel DC$ .

But,  $FE \parallel AB$ .

Hence,  $AB \parallel DC$ .

Thus, ABCD is a trapezium.

**Question 22.**

In  $\triangle ABC$ , AD is perpendicular to side BC and  $AD^2 = BD \times DC$ .

Show that angle BAC =  $90^\circ$

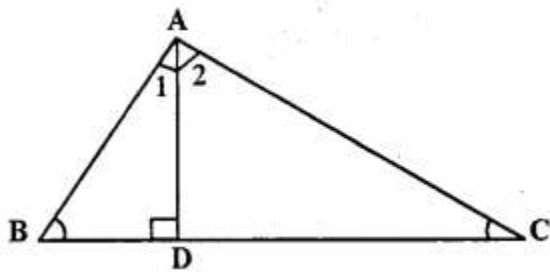

**Solution:**

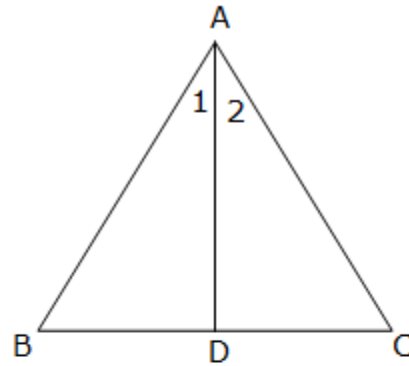

Given,  $AD^2 = BD \times DC$

$$\frac{AD}{DC} = \frac{BD}{AD}$$

$$\angle ADB = \angle ADC = 90^\circ$$

$\therefore \triangle DBA \sim \triangle DAC$  (SAS similarity)

So, these two triangles will be equiangular.

$$\therefore \angle 1 = \angle C \text{ and } \angle 2 = \angle B$$

$$\angle 1 + \angle 2 = \angle B + \angle C$$

$$\angle A = \angle B + \angle C$$

By angle sum property,

$$\angle A + \angle B + \angle C = 180^\circ$$

$$\angle A + \angle A = 180^\circ$$

$$2\angle A = 180^\circ$$

$$\angle A = \angle BAC = 90^\circ$$

**Question 23.**

In the given figure  $AB \parallel EF \parallel DC$ ;  $AB \sim 67.5$  cm.  $DC = 40.5$  cm and  $AE = 52.5$  cm.

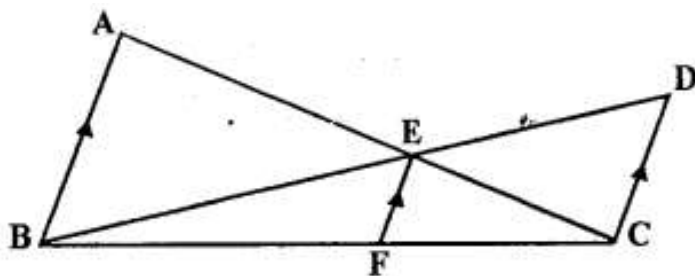

- (i) Name the three pairs of similar triangles.
- (ii) Find the lengths of EC and EF.

**Solution:**

(i) The three pair of similar triangles are:

$\triangle BEF$  and  $\triangle BDC$

$\triangle CEF$  and  $\triangle CAB$

$\triangle ABE$  and  $\triangle CDE$

(ii) Since,  $\triangle ABE$  and  $\triangle CDE$  are similar,

$$\frac{AB}{CD} = \frac{AE}{CE}$$

$$\frac{67.5}{40.5} = \frac{52.5}{CE}$$

$$CE = 31.5 \text{ cm}$$

Since,  $\triangle CEF$  and  $\triangle CAB$  are similar,

$$\frac{CE}{CA} = \frac{EF}{AB}$$

$$\frac{31.5}{52.5 + 31.5} = \frac{EF}{67.5}$$

$$\frac{31.5}{84} = \frac{EF}{67.5}$$

$$EF = \frac{2126.25}{84}$$

$$EF = \frac{405}{16} = 25\frac{5}{16} \text{ cm}$$

**Question 24.**

In the given figure, QR is parallel to AB and DR is parallel to QB.

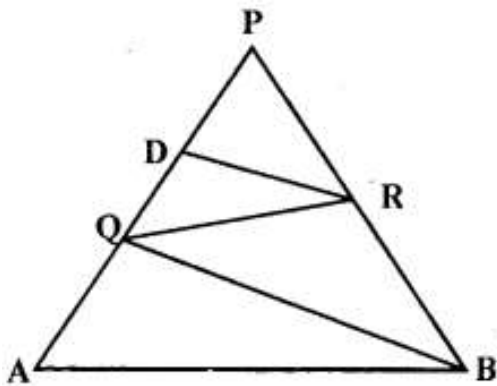

Prove that—  $PQ^2 = PD \times PA$ .

**Solution:**

Given, QR is parallel to AB. Using Basic proportionality theorem,

$$\Rightarrow \frac{PQ}{PA} = \frac{PR}{PB} \quad \dots (1)$$

Also, DR is parallel to QB. Using Basic proportionality theorem,

$$\Rightarrow \frac{PD}{PQ} = \frac{PR}{PB} \quad \dots (2)$$

From (1) and (2), we get,

$$\frac{PQ}{PA} = \frac{PD}{PQ}$$

$$PQ^2 = PD \times PA$$

**Question 25.**

Through the mid-point M of the side CD of a parallelogram ABCD, the line BM is drawn intersecting diagonal AC in L and AD produced in E.

Prove that :  $EL = 2 BL$ .

**Solution:**

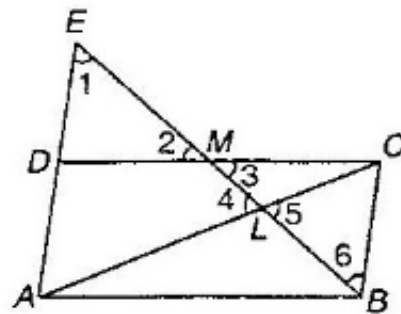

$\angle 1 = \angle 6$  (Alternate interior angles)

$\angle 2 = \angle 3$  (Vertically opposite angles)

$DM = MC$  (M is the mid-point of CD)

$\therefore \triangle DEM \cong \triangle CBM$  (AAS congruence criterion)

So,  $DE = BC$  (Corresponding parts of congruent triangles)

Also,  $AD = BC$  (Opposite sides of a parallelogram)

$\Rightarrow AE = AD + DE = 2BC$

Now,  $\angle 1 = \angle 6$  and  $\angle 4 = \angle 5$

$\therefore \triangle ELA \sim \triangle BLC$  (AA similarity)

$$\Rightarrow \frac{EL}{BL} = \frac{EA}{BC}$$

$$\Rightarrow \frac{EL}{BL} = \frac{2BC}{BC} = 2$$

$$\Rightarrow EL = 2BL$$

**Question 26.**

In the figure given below P is a point on AB such that  $AP : PB = 4 : 3$ . PQ is parallel to AC.

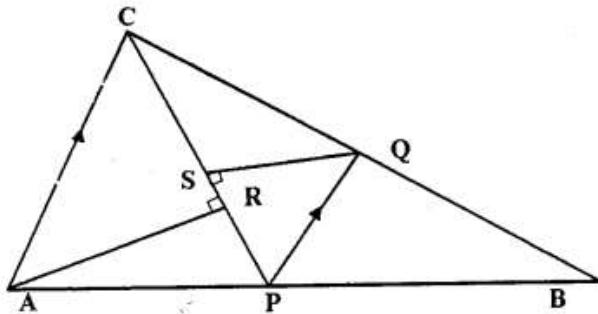

- (i) Calculate the ratio  $PQ : AC$ , giving reason for your answer.  
(ii) In triangle  $ARC$ ,  $\angle ARC = 90^\circ$  and in triangle  $PQS$ ,  $\angle PSQ = 90^\circ$ . Given  $QS = 6$  cm, calculate the length of  $AR$ . [1999]

**Solution:**

(i) Given,  $AP : PB = 4 : 3$ .

Since,  $PQ \parallel AC$ . Using Basic Proportionality theorem,

$$\frac{AP}{PB} = \frac{CQ}{QB}$$

$$\Rightarrow \frac{CQ}{QB} = \frac{4}{3}$$

$$\Rightarrow \frac{BQ}{BC} = \frac{3}{7} \quad \dots (1)$$

Now,  $\angle PQB = \angle ACB$  (Corresponding angles)

$\angle QPB = \angle CAB$  (Corresponding angles)

$\therefore \triangle PBQ \sim \triangle ABC$  (AA similarity)

$$\Rightarrow \frac{PQ}{AC} = \frac{BQ}{BC}$$

$$\Rightarrow \frac{PQ}{AC} = \frac{3}{7} \quad [\text{Using (1)}]$$

(ii)  $\angle ARC = \angle QSP = 90^\circ$

$\angle ACR = \angle SPQ$  (Alternate angles)

$\therefore \triangle ARC \sim \triangle QSP$  (AA similarity)

$$\Rightarrow \frac{AR}{QS} = \frac{AC}{PQ}$$

$$\Rightarrow \frac{AR}{QS} = \frac{7}{3}$$

$$\Rightarrow AR = \frac{7 \times 6}{3} = 14 \text{ cm}$$



**Question 27.**

In the right angled triangle QPR, PM is an altitude.

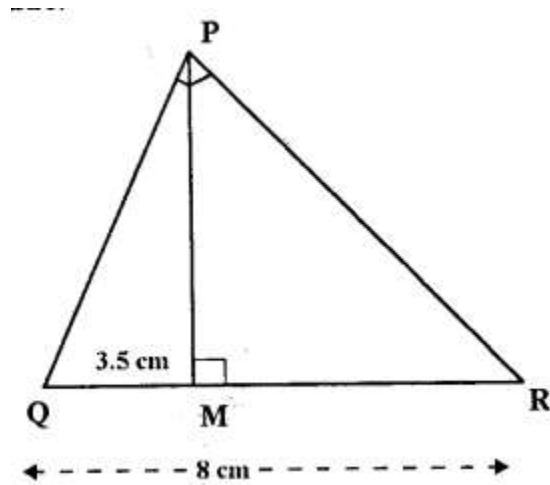

Given that QR = 8 cm and MQ = 3.5 cm. Calculate, the value of PR., [2000]

Given— In right angled  $\Delta QPR$ ,  $\angle P = 90^\circ$   $PM \perp QR$ , QR = 8 cm, MQ = 3.5 cm  
Calculate— PR

**Solution:**

We have:

$$\angle QPR = \angle PMR = 90^\circ$$

$$\angle PRQ = \angle PRM \quad (\text{Common})$$

$$\Delta PQR \sim \Delta MPR \quad (\text{AA similarity})$$

$$\therefore \frac{QR}{PR} = \frac{PR}{MR}$$

$$PR^2 = 8 \times 4.5 = 36$$

$$PR = 6 \text{ cm}$$

**Question 28.**

In the figure given below, the medians BD and CE of a triangle ABC meet at G.  
Prove that—

(i)  $\Delta EGD \sim \Delta CGB$

(ii)  $BG = 2 GD$  from (i) above.

**Solution:**

(i) Since, BD and CE are medians.

$$AD = DC$$

$$AE = BE$$

Hence, by converse of Basic Proportionality theorem,

$$ED \parallel BC$$

In  $\triangle EGD$  and  $\triangle CGB$ ,

$$\angle DEG = \angle GCB \quad (\text{Alternate angles})$$

$$\angle EGD = \angle BGC \quad (\text{Vertically opposite angles})$$

$$\triangle EGD \sim \triangle CGB \quad (\text{AA similarity})$$

(ii) Since,  $\triangle EGD \sim \triangle CGB$

$$\frac{GD}{GB} = \frac{ED}{BC} \quad \dots (1)$$

In  $\triangle AED$  and  $\triangle ABC$ ,

$$\angle AED = \angle ABC \quad (\text{Corresponding angles})$$

$$\angle EAD = \angle BAC \quad (\text{Common})$$

$$\triangle AED \sim \triangle ABC \quad (\text{AA similarity})$$

$$\therefore \frac{ED}{BC} = \frac{AE}{AB} = \frac{1}{2} \quad (\text{Since, E is the mid-point of AB})$$

$$\Rightarrow \frac{ED}{BC} = \frac{1}{2}$$

From (1),

$$\frac{GD}{GB} = \frac{1}{2}$$

$$GB = 2GD$$

## Exercise 15B

**Question 1.**

In the following figure, point D divides AB in the ratio 3:5. Find:

(i)  $\frac{AE}{EC}$

(ii)  $\frac{AD}{AB}$

(iii)  $\frac{AE}{AC}$

Also, if:

(iv)  $DE = 2.4$  cm, find the length of BC.

(v)  $BC = 4.8$  cm, find the length of  $DE$ .

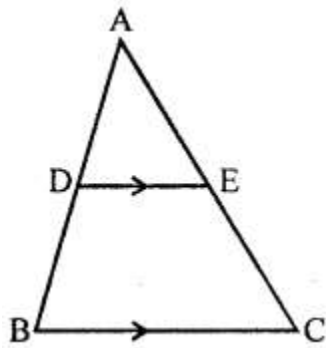

**Solution:**

(i).

$$\text{Given that } \frac{AD}{DB} = \frac{3}{5}.$$

$$\text{So, } \frac{AD}{AB} = \frac{3}{8}.$$

In  $\triangle ADE$  and  $\triangle ABC$ ,

$\angle ADE = \angle ABC$  .... (Since  $DE \parallel BC$ , so the angles are corresponding angles.)

$\angle A = \angle A$  .... (Common angle)

$\therefore \triangle ADE \sim \triangle ABC$  ... (AA criterion for Similarity)

$$\Rightarrow \frac{AD}{AB} = \frac{AE}{AC}$$

$$\Rightarrow \frac{AE}{AC} = \frac{3}{8}$$

(ii)

$$\text{Given that } \frac{AD}{DB} = \frac{3}{5}.$$

$$\text{So, } \frac{AD}{AB} = \frac{3}{8}.$$

(iii)

$$\text{Given that } \frac{AD}{DB} = \frac{3}{5}.$$

$$\text{So, } \frac{AD}{AB} = \frac{3}{8}.$$

In  $\triangle ADE$  and  $\triangle ABC$ ,

$\angle ADE = \angle ABC$  .... (Since  $DE \parallel BC$ , so the angles are corresponding angles.)

$\angle A = \angle A$  .... (Common angle)

$\therefore \triangle ADE \sim \triangle ABC$  ... (AA criterion for Similarity)

$$\Rightarrow \frac{AD}{AB} = \frac{AE}{AC}$$

$$\Rightarrow \frac{AE}{AC} = \frac{3}{8}$$

(iv)

$$\text{Given that } \frac{AD}{DB} = \frac{3}{5}.$$

$$\text{So, } \frac{AD}{AB} = \frac{3}{8}.$$

In  $\triangle ADE$  and  $\triangle ABC$ ,

$\angle ADE = \angle ABC$  .... (Since  $DE \parallel BC$ , so the angles are corresponding angles.)

$\angle A = \angle A$  .... (Common angle)

$\therefore \triangle ADE \sim \triangle ABC$  ... (AA criterion for Similarity)

$$\Rightarrow \frac{AD}{AB} = \frac{DE}{BC}$$

$$\Rightarrow \frac{3}{8} = \frac{2.4}{BC}$$

$$\Rightarrow BC = 6.4 \text{ cm}$$

(v)

Given that  $\frac{AD}{DB} = \frac{3}{5}$ .

So,  $\frac{AD}{AB} = \frac{3}{8}$ .

In  $\triangle ADE$  and  $\triangle ABC$ ,

$\angle ADE = \angle ABC$  .... (Since  $DE \parallel BC$ , so the angles are corresponding angles.)

$\angle A = \angle A$  .... (Common angle)

$\therefore \triangle ADE \sim \triangle ABC$  ... (AA criterion for Similarity)

$$\Rightarrow \frac{AD}{AB} = \frac{DE}{BC}$$

$$\Rightarrow \frac{3}{8} = \frac{DE}{4.8}$$

$$\Rightarrow DE = 1.8 \text{ cm}$$

**Question 2.**

In the given figure,  $PQ \parallel AB$ ;

$CQ = 4.8 \text{ cm}$   $QB = 3.6 \text{ cm}$  and  $AB = 6.3 \text{ cm}$ . Find:

(i)  $\frac{CP}{PA}$

(ii)  $PQ$

(iii) If  $AP = x$ , then the value of  $AC$  in terms of  $x$ .

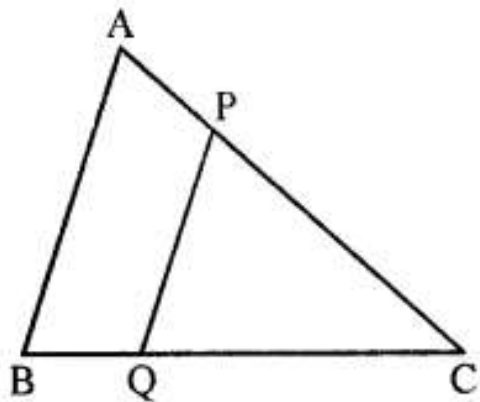

**Solution:**

(i)

In  $\triangle CPQ$  and  $\triangle CAB$ ,

$\angle PCQ = \angle ACB$  .... (Since  $PQ \parallel AB$ , so the angles are corresponding angles.)

$\angle C = \angle C$  .... (Common angle)

$\therefore \triangle CPQ \sim \triangle CAB$  ... (AA criterion for Similarity)

$$\Rightarrow \frac{CP}{CA} = \frac{CQ}{CB}$$

$$\Rightarrow \frac{CP}{CA} = \frac{4.8}{8.4} = \frac{4}{7}$$

$$\text{So, } \frac{CP}{PA} = \frac{4}{3}$$

(ii)

In  $\triangle CPQ$  and  $\triangle CAB$ ,

$\angle PCQ = \angle ACB$  .... (Since  $PQ \parallel AB$ , so the angles are corresponding angles.)

$\angle C = \angle C$  .... (Common angle)

$\therefore \triangle CPQ \sim \triangle CAB$  ... (AA criterion for Similarity)

$$\Rightarrow \frac{PQ}{AB} = \frac{CQ}{CB}$$

$$\Rightarrow \frac{PQ}{6.3} = \frac{4.8}{8.4}$$

$$\Rightarrow PQ = 3.6 \text{ cm}$$

(iii)

In  $\triangle CPQ$  and  $\triangle CAB$ ,

$\angle PCQ = \angle ACB$  .... (Since  $PQ \parallel AB$ , so the angles are corresponding angles.)

$\angle C = \angle C$  .... (Common angle)

$\therefore \triangle CPQ \sim \triangle CAB$  ... (AA criterion for Similarity)

$$\Rightarrow \frac{CP}{AC} = \frac{CQ}{CB}$$

$$\Rightarrow \frac{CP}{AC} = \frac{4.8}{8.4} = \frac{4}{7}$$

So, if AC is 7 parts, and CP is 4 parts, then PA is 3 parts.

$$\text{Thus, } AC = \frac{7}{3}PA = \frac{7}{3}x.$$

**Question 3.**

A line PQ is drawn parallel to the side BC of  $\triangle ABC$  which cuts side AB at P and side AC at Q. If  $AB = 9.0$  cm,  $CA = 6.0$  cm and  $AQ = 4.2$  cm, find the length of AP.

**Solution:**

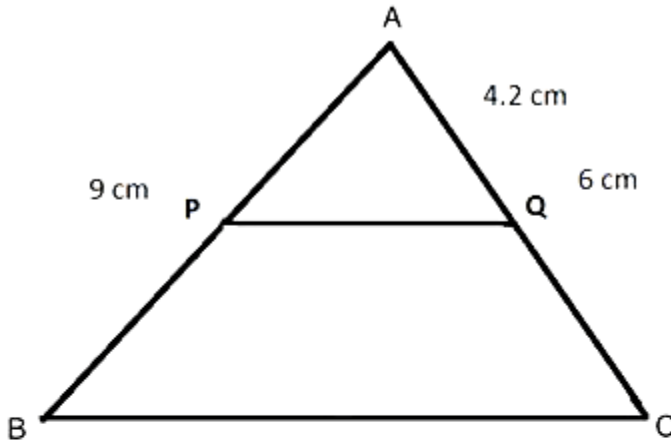

In  $\triangle APQ$  and  $\triangle ABC$ ,

$\angle ACQ = \angle ABC$  .... (Since  $PQ \parallel BC$ , so the angles are corresponding angles.)

$\angle PAQ = \angle BAC$  .... (Common angle)

$\therefore \triangle APQ \sim \triangle ABC$  ... (AA criterion for Similarity)

$$\Rightarrow \frac{AP}{AB} = \frac{AQ}{AC}$$

$$\Rightarrow \frac{AP}{9} = \frac{4.2}{6}$$

$$\Rightarrow AP = 6.3 \text{ cm}$$

**Question 4.**

In  $\triangle ABC$ , D and E are the points on sides AB and AC respectively.

Find whether  $DE \parallel BC$ , if:

(i)  $AB = 9$  cm,  $AD = 4$  cm,  $AE = 6$  cm and  $EC = 7.5$  cm.

(ii)  $AB = 63$  cm,  $EC = 11.0$  cm,  $AD = 0.8$  cm and  $AE = 1.6$  cm.

**Solution:**

(i).

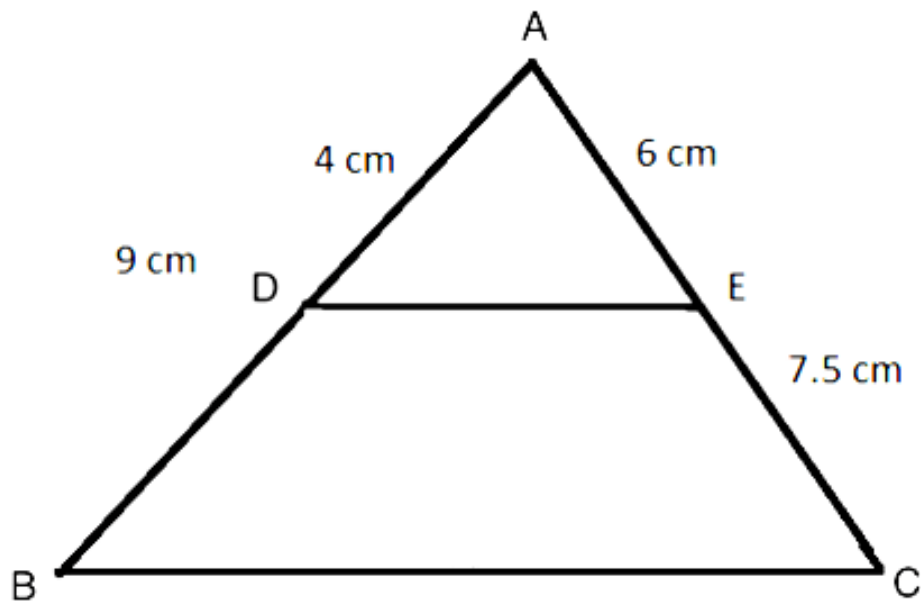

In  $\triangle ADE$  and  $\triangle ABC$ ,

$$\frac{AE}{EC} = \frac{6}{7.5} = \frac{4}{5}$$

$$\frac{AD}{BD} = \frac{4}{5} \quad \dots (\text{Since } AB = 9 \text{ cm and } AD = 4 \text{ cm})$$

$$\text{So, } \frac{AE}{EC} = \frac{AD}{BD}$$

$\therefore DE \parallel BC \quad \dots (\text{By the Converse of Mid-point theorem})$



(ii).

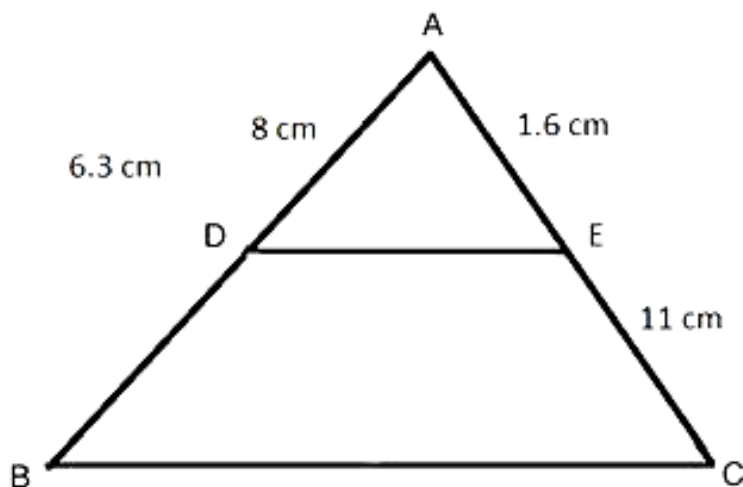

In  $\triangle ADE$  and  $\triangle ABC$ ,

$$\frac{AE}{EC} = \frac{1.6}{11} = \frac{0.8}{5.5}$$

$$\frac{AD}{BD} = \frac{0.8}{6.3 - 8} = \frac{0.8}{5.5}$$

$$\text{So, } \frac{AE}{EC} = \frac{AD}{BD}.$$

$\therefore DE \parallel BC$  ....(By the Converse of Mid-point theorem)

**Question 5.**

In the given figure,  $\triangle ABC \sim \triangle ADE$ . If  $AE: EC = 4 : 7$  and  $DE = 6.6$  cm, find  $BC$ . If 'x' be the length of the perpendicular from  $A$  to  $DE$ , find the length of perpendicular from

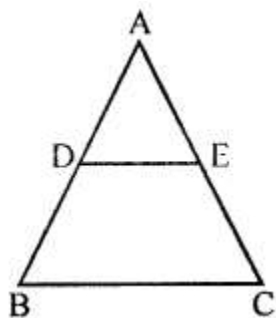

A to DE find the length of perpendicular from A to BC in terms of 'x'.

**Solution:**

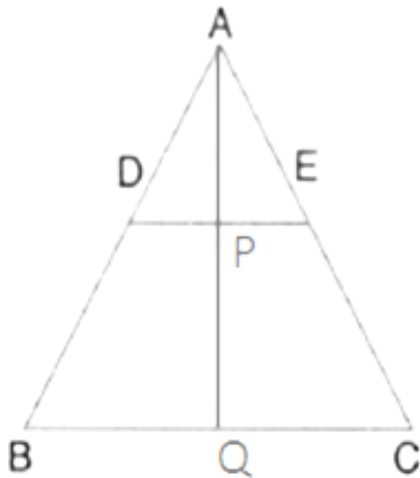

Given that  $\triangle ABC \sim \triangle ADE$ .

$\angle ABC = \angle ADE$  and  $\angle ACB = \angle AED$

So,  $DE \parallel BC$

Also,  $\frac{AB}{AD} = \frac{AC}{AE} = \frac{11}{4}$ . .... (Since  $\frac{AE}{EC} = \frac{4}{7}$ )

In  $\triangle ADP$  and  $\triangle ABQ$ ,

$\angle ADP = \angle ABQ$  ... (Since  $DP \parallel BQ$ .)

$\angle APD = \angle AQB$  ... (Since  $DP \parallel BQ$ .)

So,  $\triangle ADP \sim \triangle ABQ$  ... (AA Criterion for Similarity)

$$\Rightarrow \frac{AD}{AB} = \frac{AP}{AQ}$$

$$\Rightarrow \frac{4}{11} = \frac{x}{AQ}$$

$$\Rightarrow AQ = \frac{11}{4}x$$

**Question 6.**

A line segment DE is drawn parallel to base BC of  $\triangle ABC$  which cuts AB at point D and AC at point E. If  $AB = 5 BD$  and  $EC = 3.2$  cm, find the length of AE.

**Solution:**

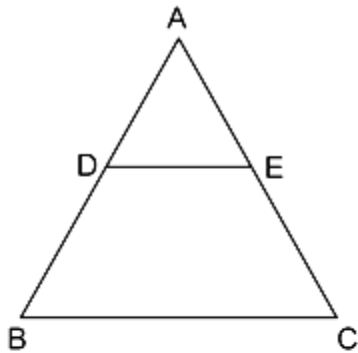

Since  $DE \parallel BC$ ,  $\triangle ADE \sim \triangle ABC$

$$\Rightarrow \frac{AD}{BD} = \frac{AE}{EC}$$

$$\Rightarrow \frac{AB - BD}{BD} = \frac{AE}{EC}$$

$$\Rightarrow \frac{5BD - BD}{BD} = \frac{AE}{EC}$$

$$\Rightarrow \frac{4BD}{BD} = \frac{AE}{3.2}$$

$$\Rightarrow AE = 4 \times 3.2 = 12.8 \text{ cm}$$

**Question 7.**

In the figure, given below, AB, CD and EF are parallel lines. Given  $AB = 7.5 \text{ cm}$ ,  $DC = y \text{ cm}$ ,  $EF = 4.5 \text{ cm}$ ,  $BC = x \text{ cm}$  and  $CE = 3 \text{ cm}$ , calculate the values of  $x$  and  $y$ .

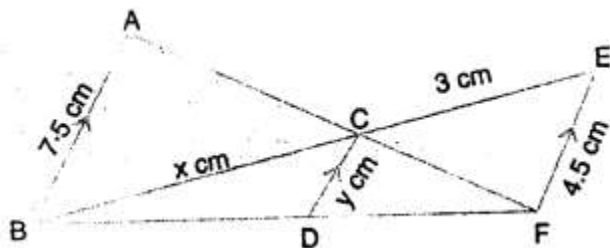

**Solution:**

In  $\triangle BEF$ ,  $DC \parallel EF$ .

$$\Rightarrow \frac{BD}{DF} = \frac{BC}{CE}$$

$$\Rightarrow \frac{BD}{DF} = \frac{x}{3}$$

So,  $BD = x$  and  $DF = 3$ .

In  $\triangle AFB$ ,  $DC \parallel AB$ .

$$\Rightarrow \frac{FD}{CD} = \frac{FB}{AB}$$

$$\Rightarrow \frac{FD}{CD} = \frac{FD + DB}{AB}$$

$$\Rightarrow \frac{3}{y} = \frac{x+3}{7.5} \dots(i)$$

In  $\triangle BFE$ ,  $DC \parallel EF$ .

$$\Rightarrow \frac{BC}{CD} = \frac{BE}{EF}$$

$$\Rightarrow \frac{BC}{CD} = \frac{BC + CE}{EF}$$

$$\Rightarrow \frac{x}{y} = \frac{x+3}{4.5}$$

$$\Rightarrow y = \frac{4.5x}{x+3} \dots(ii)$$

Substituting (ii) in (i), we get

$$\frac{3}{\frac{4.5x}{x+3}} = \frac{x+3}{7.5}$$

$$\Rightarrow \frac{3x+9}{4.5x} = \frac{x+3}{7.5}$$

$$\Rightarrow 22.5x + 67.5 = 4.5x^2 + 13.5x$$

$$\Rightarrow 4.5x^2 + 13.5x - 22.5x - 67.5 = 0$$

$$\Rightarrow x^2 - 2x - 15 = 0$$

$$\Rightarrow (x-5)(x+3) = 0$$

So,  $x = 5$  and  $x = -3$ .

Since side of a triangle cannot be negative,  $x = 5$ .

Substituting this value in (ii), we get

$$y = \frac{4.5(5)}{x+3} = 2.8125$$

Hence,  $x = 5$  and  $y = 2.8125$

### Question 8.

In the figure, given below, PQR is a right- angle triangle right angled at Q. XY is parallel to QR, PQ = 6 cm, PY=4 cm and  $PX : XQ = 1:2$ . Calculate the lengths of PR and QR.

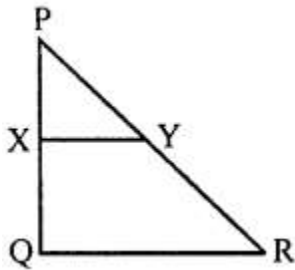

### Solution:

Given that  $\frac{PX}{XQ} = \frac{1}{2}$  and  $XY \parallel QR$ .

$$\text{So, } \frac{PX}{XQ} = \frac{PY}{YR} = \frac{1}{2}.$$

Since  $PY = 4$  cm,  $YR = 8$  cm.

Hence,  $PR = 12$  cm.

Since  $\Delta PQR$  is a right-angled triangle.

By Pythagoras theorem,

$$QR^2 = PR^2 - PQ^2$$

$$\Rightarrow QR^2 = 12^2 - 6^2$$

$$\Rightarrow QR^2 = 144 - 36$$

$$\Rightarrow QR^2 = 108$$

$$\Rightarrow QR = 10.39 \text{ cm}$$

**Question 9.**

In the following figure, M is mid-point of BC of a parallelogram ABCD. DM intersects the diagonal AC at P and AB produced at E. Prove that  $PE = 2PD$ .

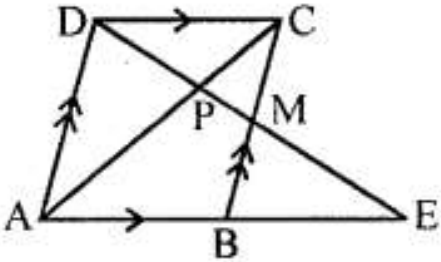
**Solution:**

In  $\triangle BME$  and  $\triangle DMC$ ,

$\angle BME = \angle CMD$  ...(vertically opposite angles)

$\angle MCD = \angle MBE$  ...(alternate angles)

$BM = MC$  ...(M is the mid-point of BC)

So,  $\triangle BME \cong \triangle DMC$  ...(AAS congruence criterion)

$\Rightarrow BE = DC = AB$

In  $\triangle DCP$  and  $\triangle EPA$ ,

$\angle DPC = \angle EPA$  ...(vertically opposite angles)

$\angle CDP = \angle AEP$  ...(alternate angles)

$\triangle DCP \sim \triangle EPA$  ...(AA criterion for Similarity)

$$\Rightarrow \frac{DC}{EA} = \frac{CP}{AP} = \frac{PD}{EP}$$

$$\Rightarrow \frac{DC}{EA} = \frac{PD}{PE}$$

$$\Rightarrow \frac{EA}{DC} = \frac{PE}{PD}$$

$$\Rightarrow \frac{PE}{PD} = \frac{AB + EA}{DC}$$

$$\Rightarrow \frac{PE}{PD} = \frac{2DC}{DC}$$

$$\Rightarrow PE = 2PD$$

**Question 10.**

The given figure shows a parallelogram ABCD. E is a point in AD and CE produced meets BA produced at point F. If AE=4 cm, AF = 8 cm and AB = 12 cm, find the perimeter of the parallelogram ABCD.

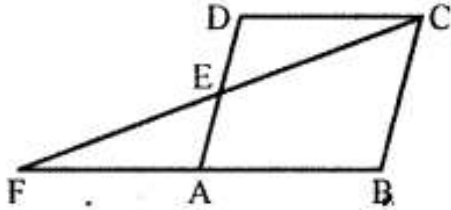
**Solution:**

AF = 8 cm and AB = 12 cm

So, FB = 20 cm.

In  $\triangle DEC$  and  $\triangle EAF$ ,

$\angle DEC = \angle EAF$  ... (vertically opposite angles)

$\angle EDC = \angle EAF$  ... (alternate angles)

So,  $\triangle DEC \sim \triangle EAF$  ... (AA criterion for Similarity)

$$\Rightarrow \frac{DE}{AE} = \frac{EC}{EF} = \frac{DC}{AF}$$

$$\Rightarrow \frac{DE}{AE} = \frac{DC}{AF}$$

$$\Rightarrow \frac{DE}{AE} = \frac{AB}{AF}$$

$$\Rightarrow \frac{DE}{4} = \frac{12}{8}$$

$$\Rightarrow DE = 6 \text{ cm}$$

So, AD = AE + ED = 4 + 6 = 10 cm

Perimeter of the parallelogram ABCD

$$= AB + BC + CD + AD$$

$$= 12 + 10 + 12 + 10$$

$$= 44 \text{ cm}$$

**Exercise 15C****Question 1.**

(i) The ratio between the corresponding sides of two similar triangles is 2 is to 5. Find the ratio between the areas of these triangles.

(ii) Areas of two similar triangles are 98 sq. cm and 128 sq. cm. Find the ratio between

the lengths of their corresponding sides.

**Solution:**

We know that the ratio of the areas of two similar triangles is equal to the ratio of squares of their corresponding sides.

$$(i) \text{ Required ratio} = \frac{2^2}{5^2} = \frac{4}{25}$$

$$(ii) \text{ Required ratio} = \sqrt{\frac{98}{128}} = \sqrt{\frac{49}{64}} = \frac{7}{8}$$

**Question 2.**

A line PQ is drawn parallel to the base BC, of  $\Delta ABC$  which meets sides AB and AC at points P and Q respectively. If  $AP = \frac{1}{3} PB$ ; find the value of:

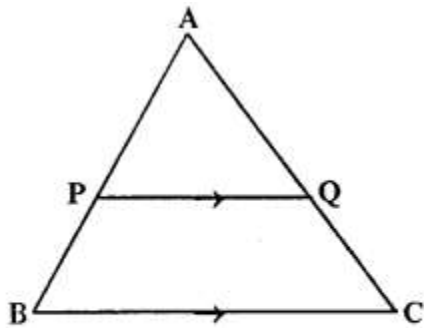

$$(i) \frac{\text{Area of } \Delta ABC}{\text{Area of } \Delta APQ}, (ii) \frac{\text{Area of } \Delta APQ}{\text{Area of trapezium } PBCQ}$$

**Solution:**

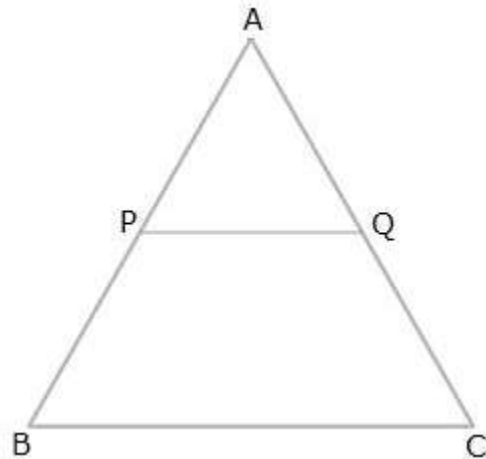



$$(i) AP = \frac{1}{3} PB \Rightarrow \frac{AP}{PB} = \frac{1}{3}$$

In  $\triangle APQ$  and  $\triangle ABC$ ,

As  $PQ \parallel BC$ , corresponding angles are equal

$$\angle APQ = \angle ABC$$

$$\angle AQP = \angle ACB$$

$$\triangle APQ \sim \triangle ABC$$

$$\begin{aligned} \frac{\text{Area of } \triangle ABC}{\text{Area of } \triangle APQ} &= \frac{AB^2}{AP^2} \\ &= \frac{4^2}{1^2} = 16 : 1 \end{aligned}$$

$$\left( \frac{AP}{PB} = \frac{1}{3} \Rightarrow \frac{AB}{AP} = \frac{4}{1} \right)$$

$$\begin{aligned} &\frac{\text{Area of } \triangle APQ}{\text{Area of trapezium } PBCQ} \\ (ii) &= \frac{\text{Area of } \triangle APQ}{\text{Area of } \triangle ABC - \text{Area of } \triangle APQ} \\ &= \frac{1}{16 - 1} = 1 : 15 \end{aligned}$$

### Question 3.

The perimeters of two similar triangles are 30 cm and 24cm. If one side of first triangle is 12cm, determine the corresponding side of the second triangle.

#### Solution:

Let  $\triangle ABC \sim \triangle DEF$

$$\begin{aligned} \text{Then, } \frac{AB}{DE} = \frac{BC}{EF} = \frac{AC}{DF} &= \frac{AB + BC + AC}{DE + EF + DF} \\ &= \frac{\text{Perimeter of } \triangle ABC}{\text{Perimeter of } \triangle DEF} \end{aligned}$$

$$\Rightarrow \frac{\text{Perimeter of } \triangle ABC}{\text{Perimeter of } \triangle DEF} = \frac{AB}{DE}$$

$$\Rightarrow \frac{30}{24} = \frac{12}{DE}$$

$$\Rightarrow DE = 9.6 \text{ cm}$$

**Question 4.**

In the given figure  $AX : XB = 3 : 5$

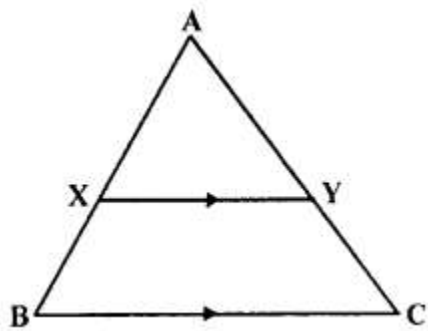

Find :

- (i) the length of BC, if length of XY is 18 cm.
- (ii) ratio between the areas of trapezium XBCY and triangle ABC.

**Solution:**

$$\text{Given, } \frac{AX}{XB} = \frac{3}{5} \Rightarrow \frac{AX}{AB} = \frac{3}{8} \quad \dots (1)$$

(i)

In  $\triangle AXY$  and  $\triangle ABC$ ,

As  $XY \parallel BC$ , corresponding angles are equal

$$\angle AXY = \angle ABC$$

$$\angle AYX = \angle ACB$$

$$\triangle AXY \sim \triangle ABC$$

$$\Rightarrow \frac{AX}{AB} = \frac{XY}{BC}$$

$$\Rightarrow \frac{3}{8} = \frac{18}{BC}$$

$$\Rightarrow BC = 48 \text{ cm}$$

(ii)

$$\frac{\text{Area of } \triangle AXY}{\text{Area of } \triangle ABC} = \frac{AX^2}{AB^2} = \frac{9}{64}$$

$$\frac{\text{Area of } \triangle ABC - \text{Area of } \triangle AXY}{\text{Area of } \triangle ABC} = \frac{64 - 9}{64} = \frac{55}{64}$$

$$\frac{\text{Area of trapezium XBCY}}{\text{Area of } \triangle ABC} = \frac{55}{64}$$

**Question 5.**

ABC is a triangle. PQ is a line segment intersecting AB in P and AC in Q such that  $PQ \parallel BC$  and divides triangle ABC into two parts equal in area. Find the value of ratio  $BP : AB$ .

Given— In  $\Delta ABC$ ,  $PQ \parallel BC$  in such away that  $\text{area } APQ = \text{area } PQCB$

To Find— The ratio of  $BP : AB$

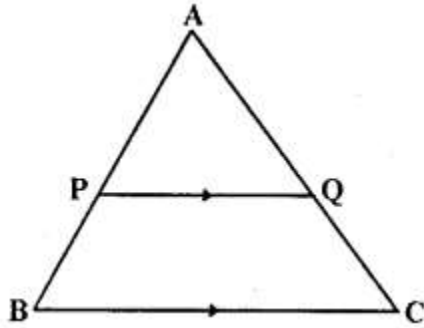

**Solution:**

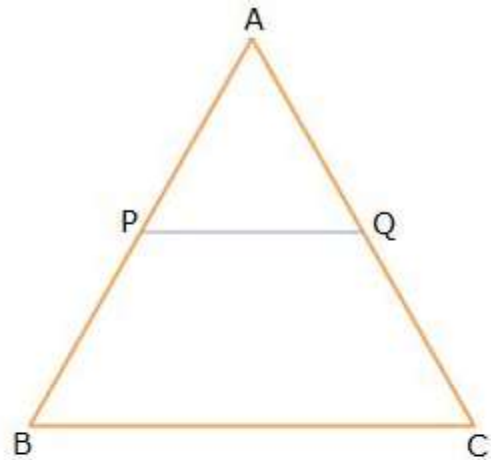

From the given information, we have:

$$\text{ar}(\Delta APQ) = \frac{1}{2} \text{ar}(\Delta ABC)$$

$$\Rightarrow \frac{\text{ar}(\Delta APQ)}{\text{ar}(\Delta ABC)} = \frac{1}{2}$$

$$\Rightarrow \frac{AP^2}{AB^2} = \frac{1}{2}$$

$$\Rightarrow \frac{AP}{AB} = \frac{1}{\sqrt{2}}$$

$$\Rightarrow \frac{AB - BP}{AB} = \frac{1}{\sqrt{2}}$$

$$\Rightarrow 1 - \frac{BP}{AB} = \frac{1}{\sqrt{2}}$$

$$\Rightarrow \frac{BP}{AB} = 1 - \frac{1}{\sqrt{2}}$$

$$\Rightarrow \frac{BP}{AB} = \frac{\sqrt{2} - 1}{\sqrt{2}} = \frac{2 - \sqrt{2}}{2}$$

**Question 6.**

In the given triangle PQR, LM is parallel to QR and PM : MR = 3 : 4

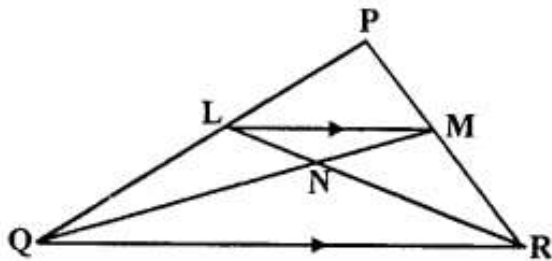

Calculate the value of ratio:

(i)  $\frac{PL}{PQ}$  and then  $\frac{LM}{QR}$  (ii)  $\frac{\text{Area of } \triangle LMN}{\text{Area of } \triangle MNR}$

(iii)  $\frac{\text{Area of } \triangle LQM}{\text{Area of } \triangle LQN}$

**Solution:**

(i)

In  $\triangle PLM$  and  $\triangle PQR$ ,

As  $LM \parallel QR$ , corresponding angles are equal

$$\angle PLM = \angle PQR$$

$$\angle PML = \angle PRQ$$

$$\triangle PLM \sim \triangle PQR$$

$$\Rightarrow \frac{PM}{PR} = \frac{LM}{QR}$$

$$\Rightarrow \frac{3}{7} = \frac{LM}{QR} \quad \left( \because \frac{PM}{MR} = \frac{3}{4} \Rightarrow \frac{PM}{PR} = \frac{3}{7} \right)$$

Also, by using Basic Proportionality theorem, we have:

$$\frac{PL}{LQ} = \frac{PM}{MR} = \frac{3}{4}$$

$$\Rightarrow \frac{LQ}{PL} = \frac{4}{3}$$

$$\Rightarrow 1 + \frac{LQ}{PL} = 1 + \frac{4}{3}$$

$$\Rightarrow \frac{PL + LQ}{PL} = \frac{3 + 4}{3}$$

$$\Rightarrow \frac{PQ}{PL} = \frac{7}{3}$$

$$\Rightarrow \frac{PL}{PQ} = \frac{3}{7}$$

(ii) Since  $\triangle LMN$  and  $\triangle MNR$  have common vertex at M and their bases LN and NR are along the same straight line

$$\therefore \frac{\text{Area of } \triangle LMN}{\text{Area of } \triangle MNR} = \frac{LN}{NR}$$

Now, in  $\triangle LNM$  and  $\triangle RNQ$ ,

$$\angle NLM = \angle NRQ \quad (\text{Alternate angles})$$

$$\angle LMN = \angle NQR \quad (\text{Alternate angles})$$

$$\triangle LNM \sim \triangle RNQ \quad (\text{AA similarity})$$

$$\therefore \frac{MN}{QN} = \frac{LN}{NR} = \frac{LM}{QR} = \frac{3}{7}$$

$$\therefore \frac{\text{Area of } \triangle LMN}{\text{Area of } \triangle MNR} = \frac{LN}{NR} = \frac{3}{7}$$

(iii) Since  $\triangle LQM$  and  $\triangle LQN$  have common vertex at L and their bases QM and QN are along the same straight line

$$\frac{\text{Area of } \triangle LQM}{\text{Area of } \triangle LQN} = \frac{QM}{QN} = \frac{10}{7}$$

$$\left( \because \frac{MN}{QN} = \frac{3}{7} \Rightarrow \frac{QM}{QN} = \frac{10}{7} \right)$$

### Question 7.

The given diagram shows two isosceles triangles which are similar also. In the given diagram, PQ and BC are not parallel:

PC = 4, AQ = 3, QB = 12, BC = 15 and AP = PQ.

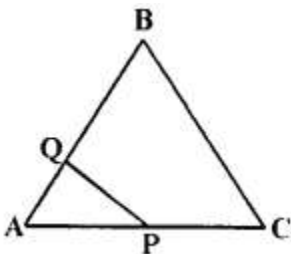

Calculate—

(i) the length of AP

(ii) the ratio of the areas of triangle APQ and triangle ABC.

**Solution:**

(i)

Given,  $\triangle AQP \sim \triangle ACB$

$$\Rightarrow \frac{AQ}{AC} = \frac{AP}{AB}$$

$$\Rightarrow \frac{3}{4+AP} = \frac{AP}{3+12}$$

$$\Rightarrow AP^2 + 4AP - 45 = 0$$

$$\Rightarrow (AP + 9)(AP - 5) = 0$$

$$\Rightarrow AP = 5 \text{ units} \quad (\text{as length cannot be negative})$$

(ii)

Since,  $\triangle AQP \sim \triangle ACB$

$$\therefore \frac{\text{ar}(\triangle APQ)}{\text{ar}(\triangle ACB)} = \frac{PQ^2}{BC^2}$$

$$\Rightarrow \frac{\text{ar}(\triangle APQ)}{\text{ar}(\triangle ABC)} = \frac{AP^2}{BC^2} \quad (PQ = AP)$$

$$\Rightarrow \frac{\text{ar}(\triangle APQ)}{\text{ar}(\triangle ABC)} = \left(\frac{5}{15}\right)^2 = \frac{1}{9}$$

**Question 8.**

In the figure, given below, ABCD is a parallelogram. P is a point on BC such that  $BP : PC = 1:2$ . DP produced meets AB produced at Q. Given the area of triangle CPQ = 20 cm<sup>2</sup>.

Calculate—

(i) area of triangle CDP

(ii) area of parallelogram ABCD [1996]

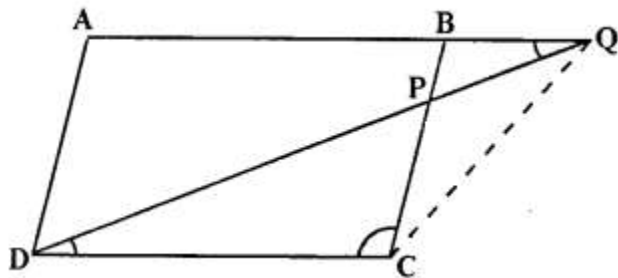

**Solution:**

(i) In  $\triangle BPQ$  and  $\triangle CPD$

$\angle BPQ = \angle CPD$  (Vertically opposite angles)

$\angle BQP = \angle PDC$  (Alternate angles)

$\triangle BPQ \sim \triangle CPD$  (AA similarity)

$$\therefore \frac{BP}{PC} = \frac{PQ}{PD} = \frac{BQ}{CD} = \frac{1}{2} \quad \left( \because \frac{BP}{PC} = \frac{1}{2} \right)$$

$$\text{Also, } \frac{\text{ar}(\triangle BPQ)}{\text{ar}(\triangle CPD)} = \left( \frac{BP}{PC} \right)^2$$

$$\Rightarrow \frac{10}{\text{ar}(\triangle CPD)} = \frac{1}{4} \quad \left[ \text{ar}(\triangle BPQ) = \frac{1}{2} \times \text{ar}(\triangle CPQ), \text{ar}(\triangle CPQ) = 20 \right]$$

$$\Rightarrow \text{ar}(\triangle CPD) = 40 \text{ cm}^2$$

(ii) In  $\triangle BQP$  and  $\triangle AQD$

As  $BP \parallel AD$ , corresponding angles are equal

$\angle QBP = \angle QAD$

$\angle BQP = \angle AQD$  (Common)

$\triangle BQP \sim \triangle AQD$  (AA similarity)

$$\therefore \frac{AQ}{BQ} = \frac{QD}{QP} = \frac{AD}{BP} = 3 \quad \left( \because \frac{BP}{PC} = \frac{PQ}{PD} = \frac{1}{2} \Rightarrow \frac{PQ}{QD} = \frac{1}{3} \right)$$

$$\text{Also, } \frac{\text{ar}(\triangle AQD)}{\text{ar}(\triangle BQP)} = \left( \frac{AQ}{BQ} \right)^2$$

$$\Rightarrow \frac{\text{ar}(\triangle AQD)}{10} = 9$$

$$\Rightarrow \text{ar}(\triangle AQD) = 90 \text{ cm}^2$$

$$\therefore \text{ar}(\triangle DPB) = \text{ar}(\triangle AQD) - \text{ar}(\triangle BQP) = 90 \text{ cm}^2 - 10 \text{ cm}^2 = 80 \text{ cm}^2$$

$$\text{ar}(\text{ABCD}) = \text{ar}(\triangle CDP) + \text{ar}(\triangle DPB) = 40 \text{ cm}^2 + 80 \text{ cm}^2 = 120 \text{ cm}^2$$

### Question 9.

In the given figure.  $BC$  is parallel to  $DE$ . Area of triangle  $ABC = 25 \text{ cm}^2$ .

Area of trapezium  $BCED = 24 \text{ cm}^2$  and  $DE = 14 \text{ cm}$ . Calculate the length of  $BC$ .

Also. Find the area of triangle  $BCD$ .

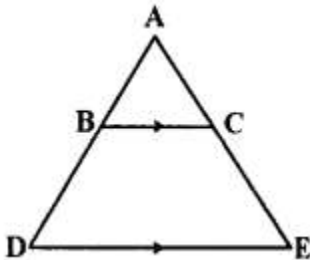

**Solution:**

In  $\triangle ABC$  and  $\triangle ADE$ ,

As  $BC \parallel DE$ , corresponding angles are equal

$$\angle ABC = \angle ADE$$

$$\angle ACB = \angle AED$$

$$\triangle ABC \sim \triangle ADE$$

$$\therefore \frac{\text{ar}(\triangle ABC)}{\text{ar}(\triangle ADE)} = \frac{BC^2}{DE^2}$$

$$\frac{25}{49} = \frac{BC^2}{14^2} \quad (\text{ar}(\triangle ADE) = \text{ar}(\triangle ABC) + \text{ar}(\text{trapezium BCED}))$$

$$BC^2 = 100$$

$$BC = 10 \text{ cm}$$

In trapezium BCED,

$$\text{Area} = \frac{1}{2}(\text{Sum of parallel sides}) \times h$$

Given : Area of trapezium BCED =  $24 \text{ cm}^2$ ,  $BC = 10 \text{ cm}$ ,  $DE = 14 \text{ cm}$

$$\therefore 24 = \frac{1}{2}(10 + 14) \times h$$

$$\Rightarrow h = \frac{48}{(10 + 14)}$$

$$\Rightarrow h = \frac{48}{24}$$

$$\Rightarrow h = 2$$

$$\text{Area of } \triangle BCD = \frac{1}{2} \times \text{base} \times \text{height}$$

$$= \frac{1}{2} \times BC \times h$$

$$= \frac{1}{2} \times 10 \times 2$$

$$\therefore \text{Area of } \triangle BCD = 10 \text{ cm}^2$$



**Question 10.**

The given figure shows a trapezium in which AB is parallel to DC and diagonals AC and BD intersect at point P. If AP : CP = 3 : 5.

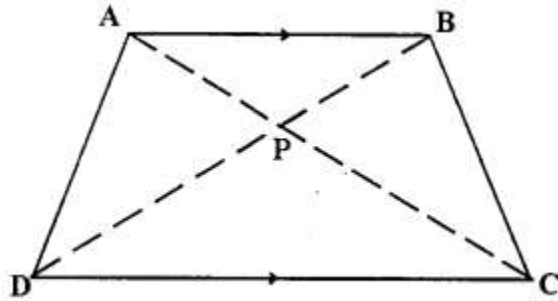

Find:

- (i)  $\Delta APB : \Delta CPB$
- (ii)  $\Delta DPC : \Delta APB$
- (iii)  $\Delta ADP : \Delta APB$
- (iv)  $\Delta APB : \Delta ADB$

**Solution:**

(i) Since  $\Delta APB$  and  $\Delta CPB$  have common vertex at B and their bases AP and PC are along the same straight line

$$\therefore \frac{\text{ar}(\Delta APB)}{\text{ar}(\Delta CPB)} = \frac{AP}{PC} = \frac{3}{5}$$

(ii) Since  $\Delta DPC$  and  $\Delta BPA$  are similar

$$\therefore \frac{\text{ar}(\Delta DPC)}{\text{ar}(\Delta BPA)} = \left(\frac{PC}{AP}\right)^2 = \left(\frac{5}{3}\right)^2 = \frac{25}{9}$$

(iii) Since  $\Delta ADP$  and  $\Delta APB$  have common vertex at A and their bases DP and PB are along the same straight line

$$\therefore \frac{\text{ar}(\Delta ADP)}{\text{ar}(\Delta APB)} = \frac{DP}{PB} = \frac{5}{3}$$

$$\left( \Delta APB \sim \Delta CPD \Rightarrow \frac{AP}{PC} = \frac{BP}{PD} = \frac{3}{5} \right)$$

(iv) Since  $\Delta APB$  and  $\Delta ADB$  have common vertex at A and their bases BP and BD are along the same straight line

$$\therefore \frac{\text{ar}(\Delta APB)}{\text{ar}(\Delta ADB)} = \frac{BP}{BD} = \frac{3}{8}$$

$$\left( \Delta APB \sim \Delta CPD \Rightarrow \frac{AP}{PC} = \frac{BP}{PD} = \frac{3}{5} \Rightarrow \frac{BP}{BD} = \frac{3}{8} \right)$$

**Question 11.**

In the given figure, ARC is a triangle. DE is parallel to BC and  $\frac{AD}{DB} = \frac{3}{2}$ .

- (i) Determine the ratios  $\frac{AD}{AB}, \frac{DE}{BC}$ .

- (ii) Prove that  $\triangle DEF$  is similar to  $\triangle CBF$ . Hence, find  $\frac{EF}{FB}$ .  
 (iii) What is the ratio of the areas of  $\triangle DEF$  and  $\triangle BFC$ ?

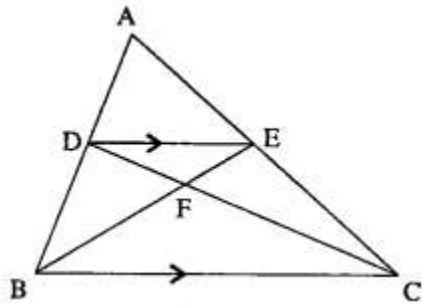

**Solution:**

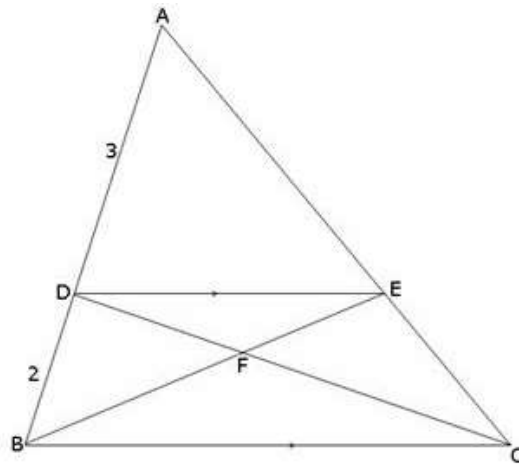

(i) Given,  $DE \parallel BC$  and  $\frac{AD}{DB} = \frac{3}{2}$

In  $\triangle ADE$  and  $\triangle ABC$ ,

$\angle A = \angle A$  (Corresponding Angles)

$\angle ADE = \angle ABC$  (Corresponding Angles)

$\therefore \triangle ADE \sim \triangle ABC$  (By AA-similarity)

$$\therefore \frac{AD}{AB} = \frac{AE}{AC} = \frac{DE}{BC} \dots\dots(1)$$

$$\text{Now } \frac{AD}{AB} = \frac{AD}{AD + DB} = \frac{3}{3 + 2} = \frac{3}{5}$$

$$\text{Using (1), we get } \frac{AD}{AB} = \frac{3}{5} = \frac{DE}{BC} \dots\dots(2)$$

(ii) In  $\triangle DEF$  and  $\triangle CBF$ ,

$\angle FDE = \angle FCB$  (Alternate Angle)

$\angle DFE = \angle BFC$  (Vertically Opposite Angle)

$\therefore \triangle DEF \sim \triangle CBF$  (By AA-similarity)

$$\frac{EF}{FB} = \frac{DE}{BC} = \frac{3}{5} \text{ using (2)}$$

$$\frac{EF}{FB} = \frac{3}{5}$$

(iii) Since the ratio of the areas of two similar triangles is equal to the square of the ratio of their corresponding sides, therefore

$$\frac{\text{Area of } \triangle DFE}{\text{Area of } \triangle CBF} = \frac{EF^2}{FB^2} = \frac{3^2}{5^2} = \frac{9}{25}$$

### Question 12.

In the given figure,  $\angle B = \angle E$ ,  $\angle ACD = \angle BCE$ ,  $AB = 10.4$  cm and  $DE = 7.8$  cm. Find the ratio between areas of the  $\triangle ABC$  and  $\triangle DEC$ .

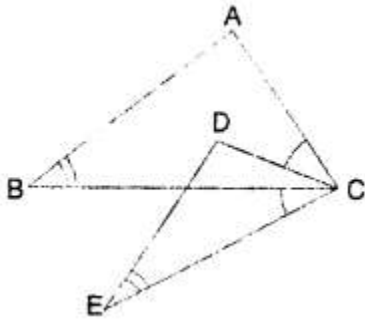

### Solution:

Given,  $\angle ACD = \angle BCE$

$\angle ACD + \angle BCD = \angle BCE + \angle BCD$

$\angle ACB = \angle DCE$

Also, given  $\angle B = \angle E$

$\therefore \triangle ABC \sim \triangle DEC$

$$\frac{\text{ar}(\triangle ABC)}{\text{ar}(\triangle DEC)} = \left(\frac{AB}{DE}\right)^2 = \left(\frac{10.4}{7.8}\right)^2 = \left(\frac{4}{3}\right)^2 = \frac{16}{9}$$

### Question 13.

Triangle ABC is an isosceles triangle in which  $AB = AC = 13$  cm and  $BC = 10$  cm. AD is perpendicular to BC. If  $CE = 8$  cm and  $EF \perp AB$ , find:

$$(i) \frac{\text{area of } \triangle ADC}{\text{area of } \triangle FEB} \quad (ii) \frac{\text{area of } \triangle FEB}{\text{area of } \triangle ABC}$$

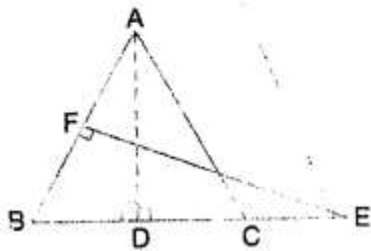

**Solution:**

(i)  $AB = AC$  (Given)

$\therefore \angle FBE = \angle ACD$

$\angle BFE = \angle ADC$

$\triangle FEB \sim \triangle ADC$  (AA similarity)

$$\begin{aligned} \therefore \frac{\text{ar}(\triangle ADC)}{\text{ar}(\triangle FEB)} &= \left(\frac{AC}{BE}\right)^2 \\ &= \left(\frac{AC}{BC + CE}\right)^2 \\ &= \left(\frac{13}{18}\right)^2 = \frac{169}{324} \quad \dots (1) \end{aligned}$$

(ii) Similarly, it can be proved that  $\triangle ADB \sim \triangle FEB$

$$\begin{aligned} \therefore \frac{\text{ar}(\triangle ADB)}{\text{ar}(\triangle FEB)} &= \left(\frac{AB}{BE}\right)^2 \\ &= \left(\frac{13}{18}\right)^2 \\ &= \frac{169}{324} \quad \dots (2) \end{aligned}$$

From (1) and (2),

$$\frac{\text{ar}(\triangle ABC)}{\text{ar}(\triangle FEB)} = \frac{169 + 169}{324} = \frac{338}{324} = \frac{169}{162}$$

$$\therefore \text{ar}(\triangle FEB) : \text{ar}(\triangle ABC) = 162 : 169$$

## Exercise 15D

### Question 1.

A triangle ABC has been enlarged by scale factor  $m = 2.5$  to the triangle  $A' B' C'$ .

Calculate:

- (i) the length of AB, if  $A'B' = 6$  cm.
- (ii) the length of  $C'A'$  if  $CA = 4$  cm.

**Solution:**

(i)

Given that ABC is a triangle that has been enlarged by scale factor  $m = 2.5$  to the triangle  $A'B'C'$ .

$$A'B' = 6 \text{ cm}$$

$$\text{So, } AB(2.5) = A'B'$$

$$\Rightarrow AB(2.5) = 6$$

$$\Rightarrow AB = 2.4 \text{ cm}$$

(ii)

Given that ABC is a triangle that has been enlarged by scale factor  $m = 2.5$  to the triangle  $A'B'C'$ .

$$A'B' = 6 \text{ cm}$$

$$\text{So, } AB(2.5) = A'B'$$

$$\Rightarrow AB(2.5) = 6$$

$$\Rightarrow AB = 2.4 \text{ cm}$$

If  $CA = 4$  cm.

$$\text{So, } CA(2.5) = C'A'$$

$$\Rightarrow (4)(2.5) = C'A'$$

$$\Rightarrow C'A' = 10 \text{ cm}$$

**Question 2.**

A triangle LMN has been reduced by scale factor 0.8 to the triangle  $L'M'N'$ . Calculate:

- (i) the length of  $M'N'$ , if  $MN = 8$  cm.
- (ii) the length of LM, if  $L'M' = 5.4$  cm.

**Solution:**

(i)

Given that LMN is a triangle that has been reduced by scale factor  $m = 0.8$  to the triangle  $L'M'N'$ .

$$MN = 8 \text{ cm}$$

$$\text{So, } MN(0.8) = M'N'$$

$$\Rightarrow (8)(0.8) = M'N'$$

$$\Rightarrow M'N' = 6.4 \text{ cm}$$

(ii)

Given that LMN is a triangle that has been reduced by scale factor  $m = 0.8$  to the triangle L'M'N'.

$$L'M' = 5.4 \text{ cm}$$

$$\text{So, } LM(0.8) = L'M'$$

$$\Rightarrow LM(0.8) = L'M'$$

$$\Rightarrow LM(0.8) = 5.4$$

$$\Rightarrow LM = 6.75 \text{ cm}$$

### Question 3.

A triangle ABC is enlarged, about the point O as centre of enlargement, and the scale factor is 3. Find:

- (i) A'B', if AB = 4 cm.
- (ii) BC, if B'C' = 15 cm.
- (iii) OA, if OA' = 6 cm.
- (iv) OC', if OC = 21 cm.

Also, state the value of:

(a)  $\frac{OB'}{OB}$

(b)  $\frac{C'A'}{CA}$

### Solution:

(i)

Given that ABC is enlarged and the scale factor  $m = 3$  to the triangle A'B'C'.

$$AB = 4 \text{ cm}$$

$$\text{So, } AB(3) = A'B'$$

$$\Rightarrow (4)(3) = A'B'$$

$$\Rightarrow A'B' = 12 \text{ cm}$$

(ii)

Given that ABC is enlarged and the scale factor  $m = 3$  to the triangle A'B'C'.

$$B'C' = 15 \text{ cm}$$

$$\text{So, } BC(3) = B'C'$$

$$\Rightarrow BC(3) = 15$$

$$\Rightarrow BC = 5 \text{ cm}$$

(iii)

Given that ABC is enlarged and the scale factor  $m = 3$  to the triangle A'B'C'.

$$OA' = 6 \text{ cm}$$

$$\text{So, } OA(3) = OA'$$

$$\Rightarrow OA(3) = 6$$

$$\Rightarrow OA = 2 \text{ cm}$$

(iv)

Given that triangle ABC is enlarged and the scale factor is  $m = 3$  to the triangle A'B'C'.

$$OC = 21 \text{ cm}$$

$$\text{So, } (OC)3 = OC'$$

$$\text{i.e. } 21 \times 3 = OC'$$

$$\text{i.e. } OC' = 63 \text{ cm}$$

The ratio of the lengths of two corresponding sides of two similar triangles.

(a) Given that ABC is enlarged and the scale factor  $m = 3$  to the triangle A'B'C'.

$$\Rightarrow \frac{OB'}{OB} = 3$$

(b) Given that ABC is enlarged and the scale factor  $m = 3$  to the triangle A'B'C'.

$$\Rightarrow \frac{C'A'}{CA} = 3$$

#### Question 4.

A model of an aeroplane is made to a scale of 1:400. Calculate:

(i) the length, in cm, of the model; if the length of the aeroplane is 40 m.

(ii) the length, in m, of the aeroplane, if length of its model is 16 cm.

#### Solution:

The ratio of the lengths of two corresponding sides of two similar triangles.

A model of an aeroplane is made to a scale of 1:400.

$$\text{So, the length of the model} = \frac{1}{400} \times 4000 = 10 \text{ cm}$$

(ii)

The ratio of the lengths of two corresponding sides of two similar triangles.

A model of an aeroplane is made to a scale of 1:400.

$$\text{So, the length of the aeroplane} = 400 \times \frac{16}{100} = 64 \text{ m}$$

**Question 5.**

The dimensions of the model of a multistory building are  $1.2 \text{ m} \times 75 \text{ cm} \times 2 \text{ m}$ . If the scale factor is 1:30; find the actual dimensions of the building.

**Solution:**

The ratio of the lengths of two corresponding sides of two similar triangles.  
The scale factor is 1:30.

The actual dimensions of the building =  $\frac{30}{1}$ (dimensions of the model of the building)

$$\Rightarrow \text{The actual dimensions of the building} = \frac{30}{1} \left(1.2 \times \frac{75}{100} \times 2\right)$$

$$\Rightarrow \text{The actual dimensions of the building} = 36 \text{ m} \times 22.5 \text{ m} \times 60 \text{ m}$$

**Question 6.**

On a map drawn to a scale of 1: 2,50,000; a triangular plot of land has the following measurements :  $AB = 3 \text{ cm}$ ,  $BC = 4 \text{ cm}$  and angle  $ABC = 90^\circ$ .

Calculate:

(i) the actual lengths of AB and BC in km.

(ii) the area of the plot in sq. km.

**Solution:**

The ratio of the lengths of two corresponding sides of two similar triangles.  
The scale factor is 1:2,50,000.

The length of AB on the map =  $\frac{1}{2,50,000}$ (the actual length of AB)

$$\Rightarrow 3 = \frac{1}{2,50,000}(\text{the actual length of AB})$$

$$\Rightarrow \text{the actual length of AB} = 3 \times 2,50,000$$

$$\Rightarrow \text{the actual length of AB} = 7,50,000 = 7.5 \text{ km}$$

The length of BC on the map =  $\frac{1}{2,50,000}$ (the actual length of BC)

$$\Rightarrow 4 = \frac{1}{2,50,000}(\text{the actual length of BC})$$

$$\Rightarrow \text{the actual length of BC} = 4 \times 2,50,000$$

$$\Rightarrow \text{the actual length of BC} = 1,00,000 = 10 \text{ km}$$



(ii)

The area of the plot in sq. km

$$= \frac{1}{2} \times AB \times BC$$

$$= \frac{1}{2} \times 7.5 \times 10$$

$$= 37.5 \text{ sq. km}$$

### Question 7.

A model of a ship is made to a scale 1 : 300

(i) The length of the model of ship is 2 m. Calculate the length of the ship.

(ii) The area of the deck of the ship is 180,000 m<sup>2</sup>. Calculate the area of the deck of the model.

(iii) The volume of the model is 6.5 m<sup>3</sup>. Calculate the volume of the ship. (2016)

### Solution:

i. Scale factor  $k = \frac{1}{300}$

Length of the model of the ship =  $k \times$  Length of the ship

$$\Rightarrow 2 = \frac{1}{300} \times \text{Length of the ship}$$

$$\Rightarrow \text{Length of the ship} = 600 \text{ m}$$

ii. Area of the deck of the model =  $k^2 \times$  Area of the deck of the ship

$$\begin{aligned} \Rightarrow \text{Area of the deck of the model} &= \left(\frac{1}{300}\right)^2 \times 180,000 \\ &= \frac{1}{90000} \times 180,000 \\ &= 2 \text{ m}^2 \end{aligned}$$

iii. Volume of the model =  $k^3 \times$  Volume of the ship

$$\Rightarrow 6.5 = \left(\frac{1}{300}\right)^3 \times \text{Volume of the ship}$$

$$\Rightarrow \text{Volume of the ship} = 6.5 \times 27000000 = 17,55,00,000 \text{ m}^3$$

### Question 7(old).

A model of ship is made to a scale of 1: 200.

(i) The length of the model is 4 m; calculate the length of the ship.

(ii) The area of the deck of the ship is 160000 m<sup>2</sup>; find the area of the deck of the model.

(iii) The volume of the model is 200 litres; calculate the volume of the ship in m<sup>3</sup>.

**Solution:**

$$\text{Scale factor} = k = \frac{1}{200}$$

(i) Length of model =  $k \times$  actual length of the ship

$$\Rightarrow \text{Actual length of the ship} = 4 \times 200 = 800 \text{ m}$$

(ii) Area of the deck of the model =  $k^2 \times$  area of the deck of the ship

$$= \left(\frac{1}{200}\right)^2 \times 160000 \text{ m}^2 = 4 \text{ m}^2$$

(iii) Volume of the model =  $k^3 \times$  volume of the ship

Volume of the ship

$$= \frac{1}{k^3} \times 200 \text{ litres}$$

$$= (200)^3 \times 200 \text{ litres}$$

$$= 1600000000 \text{ litres}$$

$$= 1600000 \text{ m}^3$$

**Question 8.**

An aeroplane is 30 m long and its model is 15 cm long. If the total outer surface area of the model is  $150 \text{ cm}^2$ , find the cost of painting the outer surface of the aeroplane at the rate of ₹ 120 per sq. m. Given that 50 sq. m of the surface of the aeroplane is left for windows.

**Solution:**

$$15 \text{ cm represents} = 30 \text{ m}$$

$$1 \text{ cm represents} \frac{30}{15} = 2 \text{ m}$$

$$1 \text{ cm}^2 \text{ represents} 2 \text{ m} \times 2 \text{ m} = 4 \text{ m}^2$$

$$\text{Surface area of the model} = 150 \text{ cm}^2$$

$$\text{Actual surface area of aeroplane} = 150 \times 4 \text{ m}^2 = 600 \text{ m}^2$$

50  $\text{m}^2$  is left out for windows

$$\text{Area to be painted} = 600 - 50 = 550 \text{ m}^2$$

$$\text{Cost of painting per m}^2 = \text{Rs. } 120$$

$$\text{Cost of painting } 550 \text{ m}^2 = 120 \times 550 = \text{Rs. } 66000$$

## Exercise 15E

### Question 1.

In the following figure,  $XY$  is parallel to  $BC$ ,  $AX = 9$  cm,  $XB = 4.5$  cm and  $BC = 18$  cm.

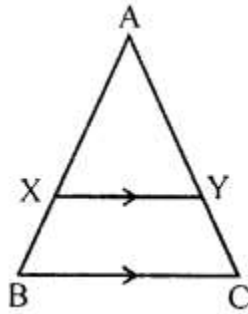

Find:

(i)  $\frac{AY}{YC}$     (ii)  $\frac{YC}{AC}$     (iii)  $XY$

**Solution:**

(i)

Given that  $XY \parallel BC$ .

So,  $\triangle AXY \sim \triangle ABC$ .

$$\Rightarrow \frac{AX}{AB} = \frac{AY}{AC}$$

$$\Rightarrow \frac{9}{13.5} = \frac{AY}{AC}$$

$$\Rightarrow \frac{AY}{YC} = \frac{2}{1}$$

(ii)

Given that  $XY \parallel BC$ .

So,  $\triangle AXY \sim \triangle ABC$ .

$$\Rightarrow \frac{AX}{AB} = \frac{AY}{AC}$$

$$\Rightarrow \frac{9}{13.5} = \frac{AY}{AC}$$

$$\Rightarrow \frac{YC}{AC} = \frac{4.5}{13.5} = \frac{1}{3}$$

**Question 2.**

In the following figure, ABCD to a trapezium with  $AB \parallel DC$ . If  $AB = 9$  cm,  $DC = 18$  cm,  $CF = 13.5$  cm,  $AP = 6$  cm and  $BE = 15$  cm.

Calculate:

- (i) EC
- (ii) AF
- (iii) PE

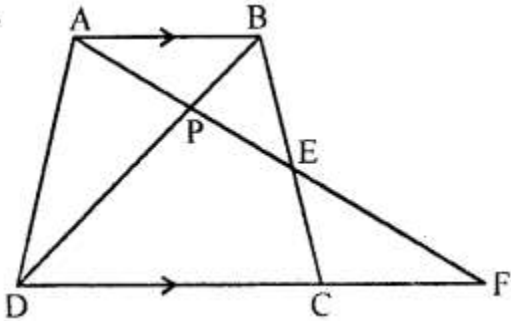
**Solution:**

(i)

In  $\triangle AEB$  and  $\triangle FEC$ ,

$\angle AEB = \angle FEC$  ... (vertically opposite angles)

$\angle BAE = \angle CFE$  ... (Since  $AB \parallel DC$ .)

$\triangle AEB \sim \triangle FEC$  ... (AA criterion for Similarity)

$$\Rightarrow \frac{AE}{FE} = \frac{BE}{CE} = \frac{AB}{FC}$$

$$\Rightarrow \frac{15}{CE} = \frac{9}{13.5}$$

$$\Rightarrow CE = 22.5 \text{ cm}$$

(ii)

In  $\triangle APB$  and  $\triangle FPD$ ,

$\angle APB = \angle FPD$  ... (vertically opposite angles)

$\angle BAP = \angle DFP$  ... (Since  $AB \parallel DF$ .)

$\triangle APB \sim \triangle FPD$  ... (AA criterion for Similarity)

$$\Rightarrow \frac{AP}{FP} = \frac{AB}{FD}$$

$$\Rightarrow \frac{6}{FP} = \frac{9}{31.5}$$

$$\Rightarrow FP = 21 \text{ cm}$$

So,  $AF = AP + PF = 6 + 21 = 27$  cm.

(iii)

In  $\triangle APB$  and  $\triangle FPD$ ,

$\angle APB = \angle FPD$  ... (vertically opposite angles)

$\angle BAP = \angle DFP$  ... (Since  $AB \parallel DF$ .)

$\triangle APB \sim \triangle FPD$  ... (AA criterion for Similarity)

$$\Rightarrow \frac{AP}{FP} = \frac{AB}{FD}$$

$$\Rightarrow \frac{6}{FP} = \frac{9}{31.5}$$

$$\Rightarrow FP = 21 \text{ cm}$$

So,  $AF = AP + PF = 6 + 21 = 27 \text{ cm}$ .

In  $\triangle AEB$  and  $\triangle FEC$ ,

$\angle AEB = \angle FEC$  ... (vertically opposite angles)

$\angle BAE = \angle CFE$  ... (Since  $AB \parallel DC$ .)

$\triangle AEB \sim \triangle FEC$  ... (AA criterion for Similarity)

$$\Rightarrow \frac{AE}{FE} = \frac{BE}{CE} = \frac{AB}{FC}$$

$$\Rightarrow \frac{AE}{FE} = \frac{9}{13.5}$$

$$\frac{AF - EF}{FE} = \frac{9}{13.5}$$

$$\Rightarrow \frac{AF}{EF} - 1 = \frac{9}{13.5}$$

$$\Rightarrow \frac{27}{EF} = \frac{9}{13.5} + 1 = \frac{22.5}{13.5}$$

$$\Rightarrow EF = \frac{27 \times 13.5}{22.5} = 16.2 \text{ cm}$$

Now,  $PE = PF - EF = 21 - 16.2 = 4.8 \text{ cm}$

### Question 3.

In the following figure,  $AB$ ,  $CD$  and  $EF$  are perpendicular to the straight line  $BDF$ .

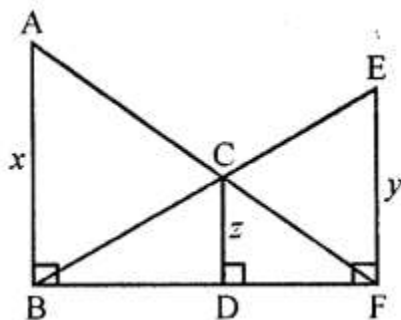

If  $AB = x$  and  $CD = z$  unit and  $EF = y$  unit, prove that :  $\frac{1}{x} + \frac{1}{y} = \frac{1}{z}$ .

**Solution:**

In  $\triangle FDC$  and  $\triangle FBA$ ,

$$\angle FDC = \angle FBA \quad \dots(\text{Since } DC \parallel AB)$$

$$\angle DFC = \angle BFA \quad \dots(\text{common angle})$$

$$\triangle FDC \sim \triangle FBA \quad \dots(\text{AA criterion for Similarity})$$

$$\Rightarrow \frac{DC}{AB} = \frac{DF}{BF}$$

$$\Rightarrow \frac{z}{x} = \frac{DF}{BF} \quad \dots(i)$$

In  $\triangle BDC$  and  $\triangle BFE$ ,

$$\angle BDC = \angle BFE \quad \dots(\text{Since } DC \parallel FE)$$

$$\angle DBC = \angle FBE \quad \dots(\text{common angle})$$

$$\triangle BDC \sim \triangle BFE \quad \dots(\text{AA criterion for Similarity})$$

$$\Rightarrow \frac{BD}{BF} = \frac{DC}{EF}$$

$$\Rightarrow \frac{BD}{BF} = \frac{z}{y} \quad \dots(ii)$$

Adding (i) and (ii), we get

$$\frac{BD}{BF} + \frac{DF}{BF} = \frac{z}{y} + \frac{z}{x}$$

$$\Rightarrow 1 = \frac{z}{y} + \frac{z}{x}$$

$$\Rightarrow \frac{1}{z} = \frac{1}{x} + \frac{1}{y}$$

Hence proved.

**Question 4.**

Triangle  $ABC$  is similar to triangle  $PQR$ . If  $AD$  and  $PM$  are corresponding medians of the two triangles, prove that:

$$\frac{AB}{PQ} = \frac{AD}{PM}$$

**Solution:**

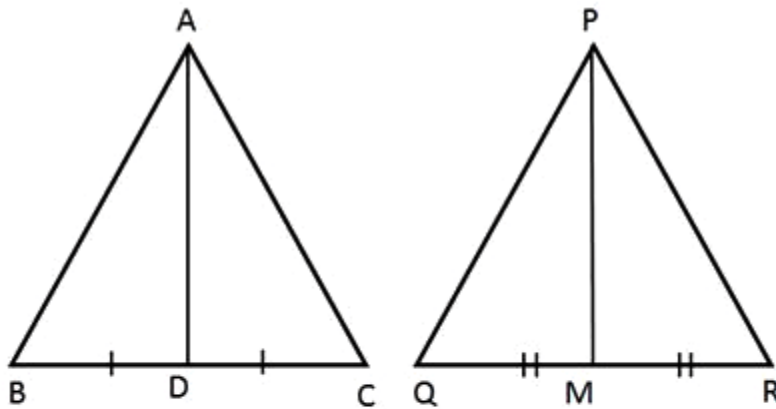

Given that  $\triangle ABC \sim \triangle PQR$ .

$$\Rightarrow \frac{AB}{PQ} = \frac{AD}{PM}$$

$\angle ABC = \angle PQR$ , that is,  $\angle ABD = \angle PQM$

Also,  $\angle ADB = \angle PMQ$  ....(both are right angles)

So,  $\triangle ABD \sim \triangle PQM$  ....(AA criterion for Similarity)

$$\Rightarrow \frac{AB}{PQ} = \frac{AD}{PM}$$

**Question 5.**

Triangle ABC is similar to triangle PQR. If AD and PM are altitudes of the two triangles,

prove that:  $\frac{AB}{PQ} = \frac{AD}{PM}$

**Solution:**

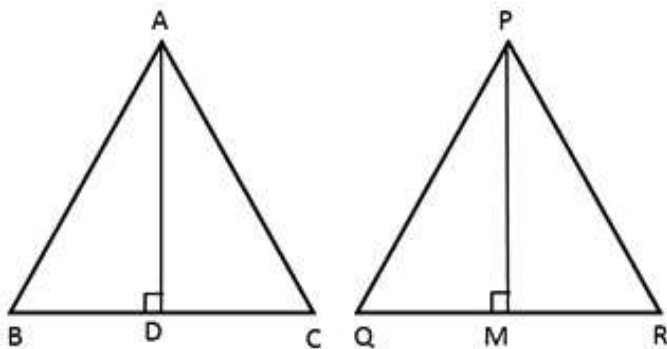

Given that  $\triangle ABC \sim \triangle PQR$ .

$\angle ABC = \angle PQR$ , that is,  $\angle ABD = \angle PQM$

Also,  $\angle ADB = \angle PMQ$  ....(both are right angles)

So,  $\triangle ABD \sim \triangle PQM$  .....(AA criterion for Similarity)

$$\Rightarrow \frac{AB}{PQ} = \frac{AD}{PM}$$

**Question 6.**

Triangle ABC is similar to triangle PQR. If bisector of angle BAC meets BC at point D and bisector of angle QPR meets QR at point M, prove that:  $\frac{AB}{PQ} = \frac{AD}{PM}$ .

**Solution:**

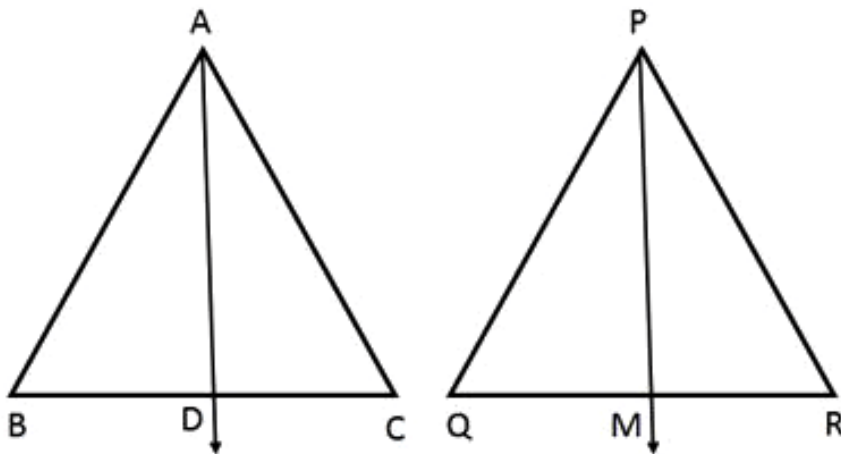

Given that  $\triangle ABC \sim \triangle PQR$ .

$$\Rightarrow \angle BAC = \angle QPR$$

$$\Rightarrow \frac{1}{2} \angle BAC = \frac{1}{2} \angle QPR$$

$$\Rightarrow \angle BAD = \angle QPM$$

Also,  $\angle ABC = \angle PQR$ , that is,  $\angle ABD = \angle PQM$

So,  $\triangle ABD \sim \triangle PQM$  .....(AA criterion for Similarity)

$$\Rightarrow \frac{AB}{PQ} = \frac{AD}{PM}$$



**Question 7.**

In the following figure,  $\angle AXY = \angle AYX$ . If  $\frac{BX}{AX} = \frac{CY}{AY}$ , show that triangle ABC is isosceles.

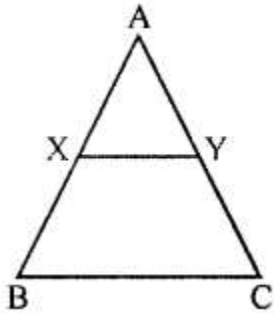
**Solution:**

Given that  $\angle AXY = \angle AYX$ .

So,  $AX = AY$ ....(Sides opposite equal angles are equal.)

Also,  $\frac{BX}{AX} = \frac{CY}{AY}$  .....(By the Basic Proportionality theorem)

So,  $BX = CY$

Thus,  $AX + BX = AY + CY$

$\Rightarrow AB = AC$

Hence,  $\triangle ABC$  is an isosceles triangle.

**Question 8.**

In the following diagram, lines  $l, m$  and  $n$  are parallel to each other. Two transversals  $p$  and  $q$  intersect the parallel lines at points  $A, B, C$  and  $P, Q, R$  as shown.

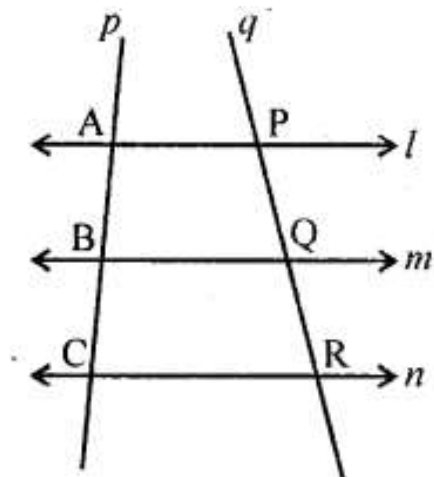

Prove that:  $\frac{AB}{BC} = \frac{PQ}{QR}$

**Solution:**

Join AR.

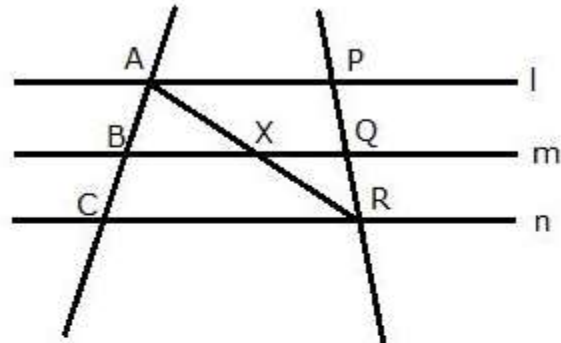

In  $\triangle ACR$ ,  $BX \parallel CR$ . By Basic Proportionality theorem,

$$\frac{AB}{BC} = \frac{AX}{XR} \quad \dots (1)$$

In  $\triangle APR$ ,  $XQ \parallel AP$ . By Basic Proportionality theorem,

$$\frac{PQ}{QR} = \frac{AX}{XR} \quad \dots (2)$$

From (1) and (2), we get,

$$\frac{AB}{BC} = \frac{PQ}{QR}$$

**Question 9.**

In the following figure,  $DE \parallel AC$  and  $DC \parallel AP$ . Prove that:  $\frac{BE}{EC} = \frac{BC}{CP}$

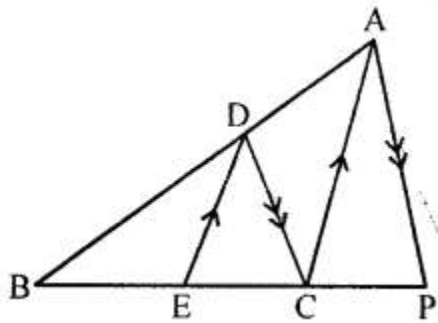

**Solution:**

Since  $DE \parallel AC$ ,

$$\frac{BE}{EC} = \frac{BD}{DA} \quad \dots \text{(By the Basic Proportionality theorem)}$$

Since  $DC \parallel AP$ ,

$$\frac{BC}{CP} = \frac{BD}{DA} \quad \dots \text{(By the Basic Proportionality theorem)}$$

$$\text{Hence, } \frac{BE}{EC} = \frac{BC}{CP}.$$

**Question 10.**

In the figure given below,  $AB \parallel EF \parallel CD$ . If  $AB = 22.5$  cm,  $EP = 7.5$  cm,  $PC = 15$  cm and  $DC = 27$  cm.

Calculate:

- (i)  $EF$
- (ii)  $AC$

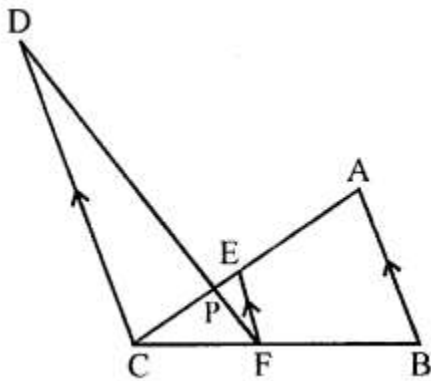

**Solution:**

(i)

In  $\triangle PCD$  and  $\triangle PEF$ ,

$$\angle CPD = \angle EPF \quad \dots \text{(vertically opposite angles)}$$

$$\angle DCE = \angle FEP \quad \dots \text{(Since } DC \parallel EF \text{.)}$$

$$\triangle PCD \sim \triangle PEF \quad \dots \text{(AA criterion for Similarity)}$$

$$\Rightarrow \frac{27}{EF} = \frac{15}{7.5}$$

$$\Rightarrow EF = 13.5 \text{ cm}$$

(ii)

In  $\triangle PCD$  and  $\triangle PEF$ ,

$\angle CPD = \angle EPF$  ....(vertically opposite angles)

$\angle DCE = \angle FEP$  ....(Since  $DC \parallel EF$ .)

$\triangle PCD \sim \triangle PEF$  ....(AA criterion for Similarity)

$$\Rightarrow \frac{27}{EF} = \frac{15}{7.5}$$

$$\Rightarrow EF = 13.5 \text{ cm}$$

Since  $EF \parallel AB$ ,  $\triangle CEF \sim \triangle CAB$ .

$$\Rightarrow \frac{EC}{AC} = \frac{EF}{AB}$$

$$\Rightarrow \frac{22.5}{AC} = \frac{13.5}{22.5}$$

$$\Rightarrow AC = 37.5 \text{ cm}$$

### Question 11.

In  $\triangle ABC$ ,  $\angle ABC = \angle DAC$ .  $AB = 8 \text{ cm}$ ,  $AC = 4 \text{ cm}$ ,  $AD = 5 \text{ cm}$ .

(i) Prove that  $\triangle ACD$  is similar to  $\triangle BCA$ .

(ii) Find  $BC$  and  $CD$ .

(iii) Find area of  $\triangle ACD$ : area of  $\triangle ABC$ . (2014)

### Solution:

(i)

In  $\triangle ACD$  and  $\triangle BCA$ ,

$\angle DAC = \angle ABC$  ....(given)

$\angle ACD = \angle BCA$  ....(common angles)

$\triangle ACD \sim \triangle BCA$  ....(AA criterion for Similarity)

(ii)

In  $\triangle ACD$  and  $\triangle BCA$ ,

$$\angle DAC = \angle ABC \quad \dots(\text{given})$$

$$\angle ACD = \angle BCA \quad \dots(\text{common angles})$$

$\triangle ACD \sim \triangle BCA \quad \dots(\text{AA criterion for Similarity})$

$$\Rightarrow \frac{AC}{BC} = \frac{CD}{CA} = \frac{AD}{AB}$$

$$\Rightarrow \frac{4}{BC} = \frac{CD}{4} = \frac{5}{8}$$

$$\Rightarrow \frac{4}{BC} = \frac{5}{8}$$

$$\Rightarrow BC = \frac{32}{5} = 6.4 \text{ cm}$$

$$\Rightarrow \frac{CD}{4} = \frac{5}{8}$$

$$\Rightarrow CD = \frac{20}{8} = 2.5 \text{ cm}$$

(iii)

In  $\triangle ACD$  and  $\triangle BCA$ ,

$$\angle DAC = \angle ABC \quad \dots(\text{given})$$

$$\angle ACD = \angle BCA \quad \dots(\text{common angles})$$

$\triangle ACD \sim \triangle BCA \quad \dots(\text{AA criterion for Similarity})$

$$\Rightarrow \frac{\text{ar}(\triangle ACD)}{\text{ar}(\triangle ABC)} = \frac{AD^2}{AB^2}$$

$$\Rightarrow \frac{\text{ar}(\triangle ACD)}{\text{ar}(\triangle ABC)} = \frac{5^2}{8^2} = \frac{25}{64}$$

### Question 12.

In the given triangle P, Q and R are the midpoints of sides AB, BC and AC respectively. Prove that triangle PQR is similar to triangle ABC.

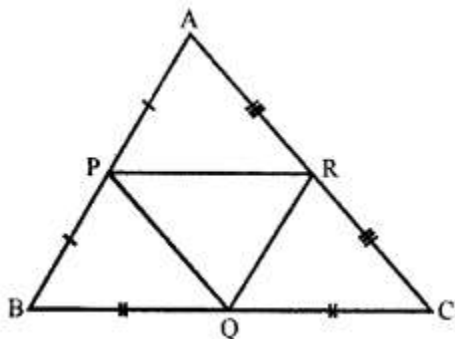

**Solution:**

In  $\triangle ABC$ ,  $PR \parallel BC$ . By Basic proportionality theorem,

$$\frac{AP}{PB} = \frac{AR}{RC}$$

Also, in  $\triangle PAR$  and  $\triangle ABC$ ,

$$\angle PAR = \angle BAC \quad (\text{Common})$$

$$\angle APR = \angle ABC \quad (\text{Corresponding angles})$$

$$\triangle PAR \sim \triangle BAC \quad (\text{AA similarity})$$

$$\frac{PR}{BC} = \frac{AP}{AB}$$

$$\frac{PR}{BC} = \frac{1}{2} \quad (\text{As P is the mid-point of AB})$$

$$PR = \frac{1}{2}BC$$

$$\text{Similarly, } PQ = \frac{1}{2}AC$$

$$RQ = \frac{1}{2}AB$$

$$\text{Thus, } \frac{PR}{BC} = \frac{PQ}{AC} = \frac{RQ}{AB}$$

$$\Rightarrow \triangle QRP \sim \triangle ABC \quad (\text{SSS similarity})$$

**Question 13.**

In the following figure, AD and CE are medians of  $\triangle ABC$ . DF is drawn parallel to CE. Prove that:

- (i)  $EF = FB$ ;
- (ii)  $AG : GD = 2 : 1$

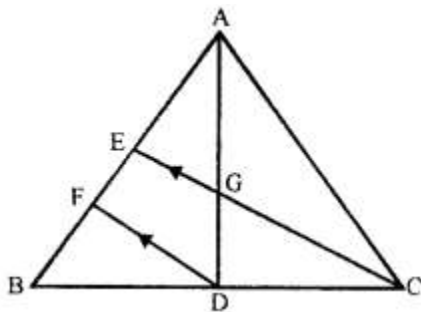

**Solution:**

(i)

In  $\triangle BFD$  and  $\triangle BEC$ ,

$$\angle BFD = \angle BEC \quad (\text{Corresponding angles})$$

$$\angle FBD = \angle EBC \quad (\text{Common})$$

$$\triangle BFD \sim \triangle BEC \quad (\text{AA similarity})$$

$$\therefore \frac{BF}{BE} = \frac{BD}{BC}$$

$$\frac{BF}{BE} = \frac{1}{2} \quad (\text{As D is the mid-point of BC})$$

$$BE = 2BF$$

$$BF = FE = 2BF$$

Hence,  $EF = FB$

(ii) In  $\triangle AFD$ ,  $EG \parallel FD$ . Using Basic Proportionality theorem,

$$\frac{AE}{EF} = \frac{AG}{GD} \dots (1)$$

Now,  $AE = EB$  (as E is the mid-point of AB)

$AE = 2EF$  (Since,  $EF = FB$ , by (i))

From (1),

$$\frac{AG}{GD} = \frac{2}{1}$$

Hence,  $AG:GD = 2:1$ .

**Question 14.**

The two similar triangles are equal in area. Prove that the triangles are congruent.

**Solution:**

Let us assume two similar triangles as  $\triangle ABC \sim \triangle PQR$

$$\text{Now } \frac{\text{area}(\triangle ABC)}{\text{area}(\triangle PQR)} = \left(\frac{AB}{PQ}\right)^2 = \left(\frac{BC}{QR}\right)^2 = \left(\frac{AC}{PR}\right)^2$$

Since  $\text{area}(\triangle ABC) = \text{area}(\triangle PQR)$

Therefore  $AB = PQ$

$$BC = QR$$

$$AC = PR$$

So, respective sides of two similar triangles are also of same length

So,  $\triangle ABC \cong \triangle PQR$  (by SSS rule)

**Question 15.**

The ratio between the altitudes of two similar triangles is 3 : 5; write the ratio between their:

- (i) medians
- (ii) perimeters
- (iii) areas

**Solution:**

The ratio between the altitudes of two similar triangles is same as the ratio between their sides.

(i) The ratio between the medians of two similar triangles is same as the ratio between their sides.

∴ Required ratio = 3: 5

(ii) The ratio between the perimeters of two similar triangles is same as the ratio between their sides.

∴ Required ratio = 3: 5

(iii) The ratio between the areas of two similar triangles is same as the square of the ratio between their corresponding sides.

∴ Required ratio =  $(3)^2 : (5)^2 = 9: 25$

**Question 16.**

The ratio between the areas of two similar triangles is 16 : 25. Find the ratio between their:

- (i) perimeters
- (ii) altitudes
- (iii) medians.

**Solution:**

The ratio between the areas of two similar triangles is same as the square of the ratio between their corresponding sides.

So, the ratio between the sides of the two triangles = 4: 5

(i) The ratio between the perimeters of two similar triangles is same as the ratio between their sides.

∴ Required ratio = 4: 5

(ii) The ratio between the altitudes of two similar triangles is same as the ratio between their sides.

∴ Required ratio = 4: 5

(iii) The ratio between the medians of two similar triangles is same as the ratio between their sides.

∴ Required ratio = 4: 5

**Question 17.**

The following figure shows a triangle PQR in which XY is parallel to QR. If PX: XQ = 1:3 and QR = 9 cm, find the length of XY.

Further, if the area of  $\Delta PXY = x \text{ cm}^2$ ; find in terms of x, the area of :

- (i) triangle PQR.
- (ii) trapezium XQRY.



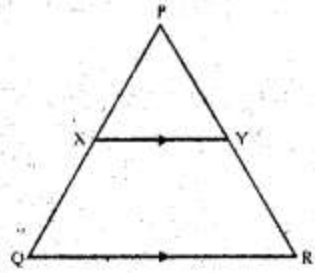

**Solution:**

In  $\Delta PXY$  and  $\Delta PQR$ ,  $XY$  is parallel to  $QR$ , so corresponding angles are equal.

$$\angle PXY = \angle PQR$$

$$\angle PYX = \angle PRQ$$

Hence,  $\Delta PXY \sim \Delta PQR$ . (By AA similarity criterion)

$$\frac{PX}{PQ} = \frac{XY}{QR}$$

$$\Rightarrow \frac{1}{4} = \frac{XY}{QR} \quad (PX : XQ = 1 : 3 \Rightarrow PX : PQ = 1 : 4)$$

$$\Rightarrow \frac{1}{4} = \frac{XY}{9}$$

$$\Rightarrow XY = 2.25 \text{ cm}$$

(i) We know that the ratio of areas of two similar triangles is equal to the ratio of the squares of their corresponding sides.

$$\frac{\text{Ar}(\Delta PXY)}{\text{Ar}(\Delta PQR)} = \left(\frac{PX}{PQ}\right)^2$$

$$\frac{x}{\text{Ar}(\Delta PQR)} = \left(\frac{1}{4}\right)^2 = \frac{1}{16}$$

$$\text{Ar}(\Delta PQR) = 16x \text{ cm}^2$$

$$(ii) \text{Ar}(\text{trapezium XQRY}) = \text{Ar}(\Delta PQR) - \text{Ar}(\Delta PXY)$$

$$= (16x - x) \text{ cm}^2$$

$$= 15x \text{ cm}^2$$

**Question 18.**

On a map, drawn to a scale of 1 : 20000, a rectangular plot of land ABCD has  $AB = 24$  cm, and  $BC = 32$  cm. Calculate :

- (i) The diagonal distance of the plot in kilometre
- (ii) The area of the plot in sq. km.

**Solution:**

Scale :- 1 : 20000

$$1 \text{ cm represents } 20000 \text{ cm} = \frac{20000}{1000 \times 100} = 0.2 \text{ km}$$

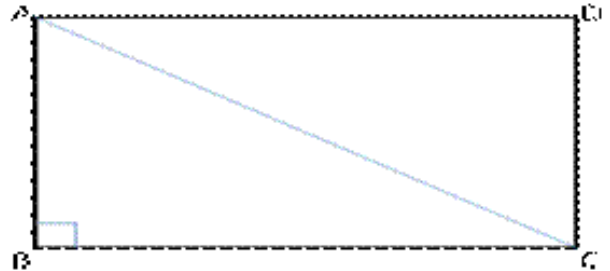

(i)

$$\begin{aligned} AC^2 &= AB^2 + BC^2 \\ &= 24^2 + 32^2 \\ &= 576 + 1024 = 1600 \\ AC &= 40 \text{ cm} \end{aligned}$$

Actual length of diagonal =  $40 \times 0.2 \text{ km} = 8 \text{ km}$

(ii)

1 cm represents 0.2 km

1 cm<sup>2</sup> represents  $0.2 \times 0.2 \text{ km}^2$

The area of the rectangle ABCD =  $AB \times BC$

$$= 24 \times 32 = 768 \text{ cm}^2$$

Actual area of the plot =  $0.2 \times 0.2 \times 768 \text{ km}^2 = 30.72 \text{ km}^2$

**Question 19.**

The dimensions of the model of a multi-storeyed building are 1m by 60 cm by 1.20 m. If the scale factor is 1 : 50, find the actual dimensions of the building. Also, find :

(i) the floor area of a room of the building, if the floor area of the corresponding room in the model is 50 sq cm.

(ii) the space (volume) inside a room of the model, if the space inside the corresponding room of the building is 90m<sup>3</sup>.

**Solution:**

The dimensions of the building are calculated as below.

$$\text{Length} = 1 \times 50 \text{ m} = 50 \text{ m}$$

$$\text{Breadth} = 0.60 \times 50 \text{ m} = 30 \text{ m}$$

$$\text{Height} = 1.20 \times 50 \text{ m} = 60 \text{ m}$$

Thus, the actual dimensions of the building are 50 m × 30 m × 60 m.

(i)

$$\text{Floor area of the room of the building} = 50 \times \left(\frac{50}{1}\right)^2 = 125000 \text{ cm}^2 = \frac{125000}{100 \times 100} = 12.5 \text{ m}^2$$

(ii)

Volume of the model of the building

$$= 90 \times \left(\frac{1}{50}\right)^3 = 90 \times \left(\frac{1}{50}\right) \times \left(\frac{1}{50}\right) \times \left(\frac{1}{50}\right) = 90 \times \left(\frac{100 \times 100 \times 100}{50 \times 50 \times 50}\right) \text{ cm}^3$$

$$= 720 \text{ cm}^3$$

**Question 20.**

In  $\triangle ABC$ ,  $\angle ACB = 90^\circ$  and  $CD \perp AB$ . Prove that :  $\frac{BC^2}{AC^2} = \frac{BD}{AD}$ .

**Solution:**

(i)

In  $\triangle PQL$  and  $\triangle RMP$

$$\angle LPQ = \angle QRP \quad (\text{Given})$$

$$\angle RQP = \angle RPM \quad (\text{Given})$$

$$\triangle PQL \sim \triangle RMP \quad (\text{AA similarity})$$

(ii)

As  $\triangle PQL \sim \triangle RMP$  (Proved above)

$$\frac{PQ}{RP} = \frac{QL}{PM} = \frac{PL}{RM}$$

$$\Rightarrow QL \times RM = PL \times PM$$

(iii)

$$\angle LPQ = \angle QRP \quad (\text{Given})$$

$$\angle Q = \angle Q \quad (\text{Common})$$

$$\triangle PQL \sim \triangle RQP \quad (\text{AA similarity})$$

$$\Rightarrow \frac{PQ}{RQ} = \frac{QL}{QP} = \frac{PL}{PR}$$

$$\Rightarrow PQ^2 = QR \times QL$$

**Question 21.**

A triangle ABC with AB = 3 cm, BC = 6 cm and AC = 4 cm is enlarged to  $\triangle DEF$  such that the longest side of  $\triangle DEF = 9$  cm. Find the scale factor and hence, the lengths of the other sides of  $\triangle DEF$ .

**Solution:**

Triangle ABC is enlarged to DEF. So, the two triangles will be similar.

$$\therefore \frac{AB}{DE} = \frac{BC}{EF} = \frac{AC}{DF}$$

Longest side in  $\triangle ABC = BC = 6$  cm

Corresponding longest side in  $\triangle DEF = EF = 9$  cm

$$\text{Scale factor} = \frac{EF}{BC} = \frac{9}{6} = \frac{3}{2} = 1.5$$

$$\therefore \frac{AB}{DE} = \frac{BC}{EF} = \frac{AC}{DF} = \frac{2}{3}$$

$$DE = \frac{3}{2}AB = \frac{9}{2} = 4.5 \text{ cm}$$

$$DF = \frac{3}{2}AC = \frac{12}{2} = 6 \text{ cm}$$

**Question 22.**

Two isosceles triangles have equal vertical angles. Show that the triangles are similar. If the ratio between the areas of these two triangles is 16 : 25, find the ratio between their corresponding altitudes.

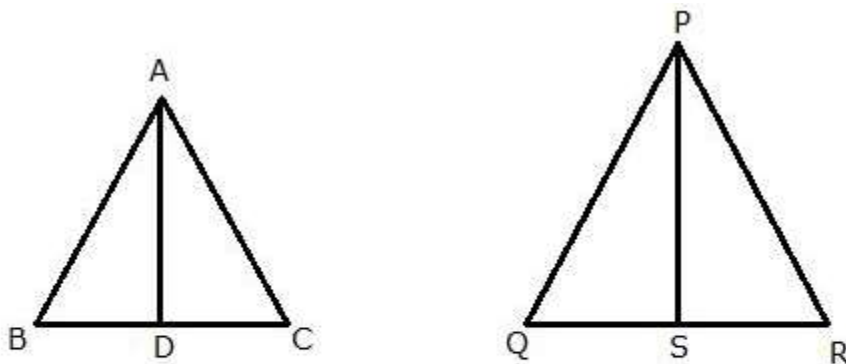
**Solution:**

Let ABC and PQR be two isosceles triangles.

$$\text{Then, } \frac{AB}{AC} = \frac{1}{1} \text{ and } \frac{PQ}{PR} = \frac{1}{1}$$

Also,  $\angle A = \angle P$  (Given)

$$\therefore \triangle ABC \sim \triangle PQR \quad (\text{SAS similarity})$$

Let AD and PS be the altitude in the respective triangles.

We know that the ratio of areas of two similar triangles is equal to the square of their corresponding altitudes.

$$\frac{\text{Ar}(\triangle ABC)}{\text{Ar}(\triangle PQR)} = \left(\frac{AD}{PS}\right)^2$$

$$\frac{16}{25} = \left(\frac{AD}{PS}\right)^2$$

$$\frac{AD}{PS} = \frac{4}{5}$$

**Question 23.**

In  $\triangle ABC$ , AP: PB = 2 :3. PO is parallel to BC and is extended to Q so that CQ is parallel to BA.

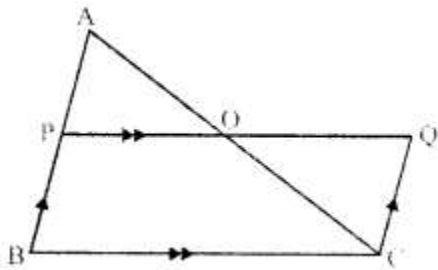

Find:

- (i) area  $\triangle APO$ : area  $\triangle ABC$ .
- (ii) area  $\triangle APO$ : area  $\triangle CQO$ .

**Solution:**

In triangle ABC, PO || BC. Using Basic proportionality theorem,

$$\frac{AP}{PB} = \frac{AO}{OC}$$

$$\Rightarrow \frac{AO}{OC} = \frac{2}{3} \quad \dots (1)$$

(i)

$$\angle PAO = \angle BAC \quad (\text{Common})$$

$$\angle APO = \angle ABC \quad (\text{Corresponding angles})$$

$$\triangle APO \sim \triangle ABC \quad (\text{AA similarity})$$

$$\therefore \frac{\text{Ar}(\triangle APO)}{\text{Ar}(\triangle ABC)} = \left(\frac{AO}{AC}\right)^2 = \left(\frac{2}{2+3}\right)^2 = \left(\frac{2}{5}\right)^2 = \frac{4}{25}$$

(ii)

$\angle POA = \angle COQ$  (Vertically opposite angles)

$\angle PAO = \angle QCO$  (Alternate angles)

$\triangle AOP \sim \triangle COQ$  (AA similarity)

$$\therefore \frac{\text{Ar}(\triangle AOP)}{\text{Ar}(\triangle COQ)} = \left(\frac{AO}{CO}\right)^2 = \left(\frac{2}{3}\right)^2 = \frac{4}{9}$$

### Question 24.

The following figure shows a triangle ABC in which AD and BE are perpendiculars to BC and AC respectively.

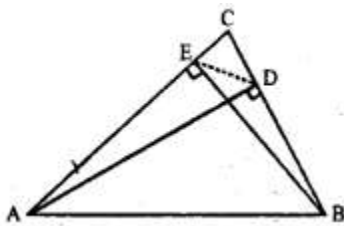

Show that:

(i)  $\triangle ADC \sim \triangle BEC$

(ii)  $CA \times CE = CB \times CD$

(iii)  $\triangle ABC \sim \triangle DEC$

(iv)  $CD \times AB = CA \times DE$

### Solution:

(i)  $\angle ADC = \angle BEC = 90^\circ$

$\angle ACD = \angle BCE$  (Common)

$\triangle ADC \sim \triangle BEC$  (AA similarity)

(ii) From part (i),

$$\frac{AC}{BC} = \frac{CD}{EC} \quad \dots (1)$$

$$\Rightarrow CA \times CE = CB \times CD$$

(iii) In  $\triangle ABC$  and  $\triangle DEC$ ,

From (1),

$$\frac{AC}{BC} = \frac{CD}{EC} \Rightarrow \frac{AC}{CD} = \frac{BC}{EC}$$

$$\begin{aligned} \angle DCE &= \angle BCA && \text{(Common)} \\ \triangle ABC &\sim \triangle DEC && \text{(SAS similarity)} \\ \text{(iv) From part (iii),} \\ \frac{AC}{DC} &= \frac{AB}{DE} \\ \Rightarrow CD \times AB &= CA \times DE \end{aligned}$$

**Question 25.**

In the given figure, ABC is a triangle-with  $\angle EDB = \angle ACB$ .

Prove that  $\triangle ABC \sim \triangle EBD$ .

If  $BE=6$  cm,  $EC = 4$  cm,

$BD = 5$  cm and area of  $\triangle BED = 9$  cm<sup>2</sup>. Calculate the

- (i) length of AB
- (ii) area of  $\triangle ABC$

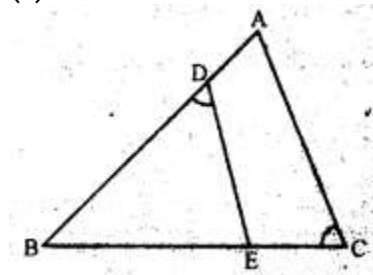

**Solution:**

In  $\triangle ABC$  and  $\triangle EBD$ ,  
 $\angle ACB = \angle EDB$  (given)  
 $\angle ABC = \angle EBD$  (common)  
 $\triangle ABC \sim \triangle EBD$  (by AA- similarity)

(i) We have,  $\frac{AB}{BE} = \frac{BC}{BD} \Rightarrow AB = \frac{6 \times 10}{5} = 12$  cm

(ii)  $\frac{\text{Area of } \triangle ABC}{\text{Area of } \triangle BED} = \left(\frac{AB}{BE}\right)^2$

$$\begin{aligned} \Rightarrow \text{Area of } \triangle ABC &= \left(\frac{12}{6}\right)^2 \times 9 \text{ cm}^2 \\ &= 4 \times 9 \text{ cm}^2 = 36 \text{ cm}^2 \end{aligned}$$

**Question 26.**

In the given figure, ABC is a right-angled triangle with  $\angle BAC = 90^\circ$ .

- (i) Prove  $\triangle ADB \sim \triangle CDA$ .
- (ii) If  $BD = 18$  cm,  $CD = 8$  cm, find  $AD$ .
- (iii) Find the ratio of the area of  $\triangle ADB$  is to area of  $\triangle CDA$ .

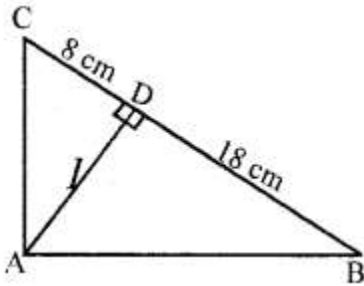
**Solution:**

- (i) Let  $\angle CAD = x$   
 $\Rightarrow m\angle DAB = 90^\circ - x$   
 $\Rightarrow m\angle DBA = 180^\circ - (90^\circ + 90^\circ - x) = x$   
 $\Rightarrow \angle CAD = \angle DBA \quad \dots(1)$

In  $\triangle ADB$  and  $\triangle CDA$ ,

$$\angle ADB = \angle CDA \quad \dots[\text{Each } 90^\circ]$$

$$\angle ABD = \angle CAD \quad \dots[\text{From (1)}]$$

$$\therefore \triangle ADB \sim \triangle CDA \quad \dots[\text{By A.A.}]$$

- (ii) Since the corresponding sides of similar triangles are proportional, we have

$$\frac{BD}{AD} = \frac{AD}{CD}$$

$$\Rightarrow \frac{18}{AD} = \frac{AD}{8}$$

$$\Rightarrow AD^2 = 18 \times 8 = 144$$

$$\Rightarrow AD = 12 \text{ cm}$$

- (iii) The ratio of the areas of two similar triangles is equal to the ratio of the squares of their corresponding sides.

$$\Rightarrow \frac{\text{Ar}(\triangle ADB)}{\text{Ar}(\triangle CDA)} = \frac{AD^2}{CD^2} = \frac{12^2}{8^2} = \frac{144}{64} = \frac{9}{4} = 9 : 4$$



**Question 27.**

In the given figure, AB and DE are perpendicular to BC.

(i) Prove that  $\triangle ABC \sim \triangle DEC$

(ii) If  $AB = 6$  cm,  $DE = 4$  cm and  $AC = 15$  cm. Calculate  $CD$ .

(iii) Find the ratio of the area of  $\triangle ABC$  : area of  $\triangle DEC$ .

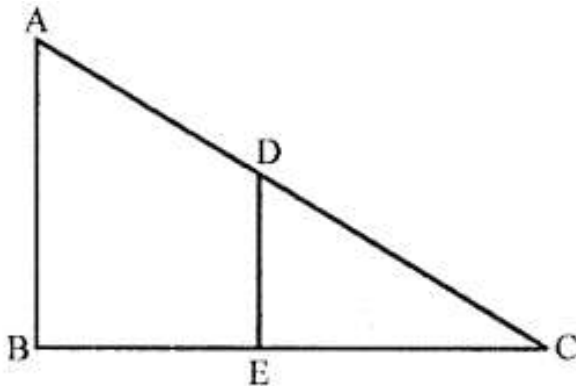
**Solution:**

(i)

In  $\triangle ABC$  and  $\triangle DEC$ ,

$\angle ABC = \angle DEC$  ....(both are right angles)

$\angle ACB = \angle DCE$  ....(common angles)

$\triangle ABC \sim \triangle DEC$  ....(AA criterion for Similarity)

(ii)

In  $\triangle ABC$  and  $\triangle DEC$ ,

$\angle ABC = \angle DEC$  ....(both are right angles)

$\angle ACB = \angle DCE$  ....(common angles)

$\triangle ABC \sim \triangle DEC$  ....(AA criterion for Similarity)

$$\Rightarrow \frac{AB}{DE} = \frac{AC}{CD}$$

$$\Rightarrow \frac{6}{4} = \frac{15}{CD}$$

$$\Rightarrow CD = 10 \text{ cm}$$

(iii)

In  $\triangle ABC$  and  $\triangle DEC$ ,

$\angle ABC = \angle DEC$ .....(both are right angles)

$\angle ACB = \angle DCE$ .....(common angles)

$\triangle ACB \sim \triangle DEC$ .....(AA criterion for Similarity)

$$\frac{\text{ar}(\triangle ABC)}{\text{ar}(\triangle DEC)} = \frac{AB^2}{DE^2} = \frac{6^2}{4^2} = \frac{36}{16}$$

$$\Rightarrow \frac{\text{ar}(\triangle ABC)}{\text{ar}(\triangle DEC)} = \frac{9}{4}$$

**Question 28.**

ABC is a right angled triangle with  $\angle ABC = 90^\circ$ . D is any point on AB and DE is perpendicular to AC. Prove that:

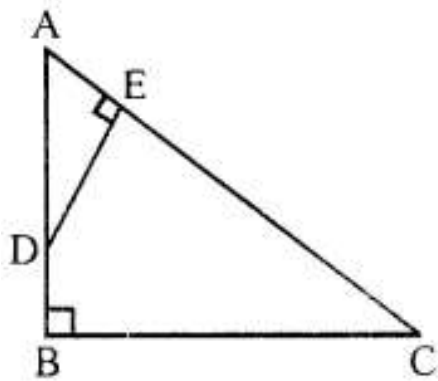

(i)  $\triangle ADE \sim \triangle ACB$ .

(ii) If  $AC = 13$  cm,  $BC = 5$  cm and  $AE = 4$  cm. Find DE and AD.

(iii) Find, area of  $\triangle ADE$  : area of quadrilateral BCED. (2015)

**Solution:**

(i)

In  $\triangle ADE$  and  $\triangle ACB$ ,

$\angle AED = \angle ABC$  ....(both are right angles)

$\angle DAE = \angle CAB$  ....(common angles)

$\triangle ADE \sim \triangle ACB$  ....(AA criterion for Similarity)

(ii)

In  $\triangle ADE$  and  $\triangle ACB$ ,

$\angle AED = \angle ABC$  ....(both are right angles)

$\angle DAE = \angle CAB$  ....(common angles)

$\triangle ADE \sim \triangle ACB$  ....(AA criterion for Similarity)

$$\Rightarrow \frac{AE}{AB} = \frac{DE}{BC} = \frac{AD}{AC}$$

$$\Rightarrow \frac{4}{AB} = \frac{DE}{5} = \frac{AD}{13} \quad \dots(i)$$

In right  $\triangle ABC$ ,

$$\Rightarrow AB^2 + BC^2 = AC^2$$

$$\Rightarrow AB^2 + 5^2 = 13^2$$

$$\Rightarrow AB^2 = 144$$

$$\Rightarrow AB = 12 \text{ cm}$$

From (i), we get

$$\frac{4}{12} = \frac{DE}{5} = \frac{AD}{13}$$

$$\text{So, } DE = \frac{20}{12} = \frac{5}{3} = 1\frac{2}{3} \text{ cm}$$

$$\frac{AD}{13} = \frac{4}{12} \Rightarrow AD = \frac{52}{12} = 4\frac{1}{3} \text{ cm}$$

(iii)

We need to find the area of  $\triangle ADE$  and quadrilateral BCED.

$$\text{Area of } \triangle ADE = \frac{1}{2} \times AE \times DE = \frac{1}{2} \times 4 \times \frac{5}{3} = \frac{10}{3} \text{ cm}^2$$

Area of quad. BCED = Area of  $\triangle ABC$  - Area of  $\triangle ADE$

$$\begin{aligned} &= \frac{1}{2} \times BC \times AB - \frac{10}{3} \\ &= \frac{1}{2} \times 5 \times 12 - \frac{10}{3} \\ &= 30 - \frac{10}{3} \\ &= \frac{80}{3} \text{ cm}^2 \end{aligned}$$

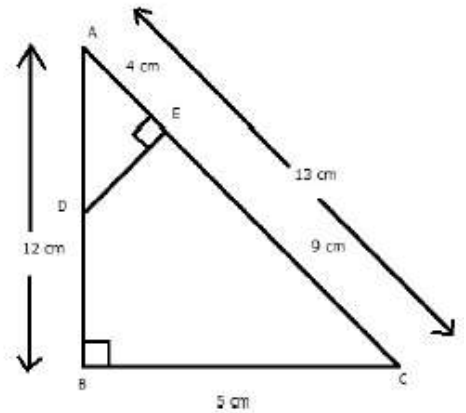

$$\text{Thus ratio of areas of } \triangle ADE \text{ to quadrilateral BCED} = \frac{\frac{10}{3}}{\frac{80}{3}} = \frac{1}{8}$$

### Question 29.

Given:  $AB \parallel DE$  and  $BC \parallel EF$ . Prove that:

(i)  $\frac{AD}{DG} = \frac{CF}{FG}$

(ii)  $\triangle DFG \sim \triangle ACG$ .

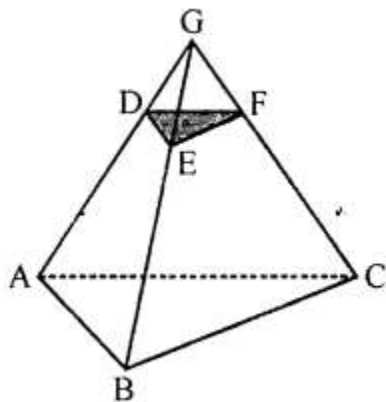

**Solution:**

(i) In  $\triangle AGB$ ,  $DE \parallel AB$ , by Basic proportionality theorem,

$$\frac{GD}{DA} = \frac{GE}{EB} \dots (1)$$

In  $\triangle GBC$ ,  $EF \parallel BC$ , by Basic proportionality theorem,

$$\frac{GE}{EB} = \frac{GF}{FC} \dots (2)$$

From (1) and (2), we get,

$$\begin{aligned} \frac{GD}{DA} &= \frac{GF}{FC} \\ \frac{AD}{DG} &= \frac{CF}{FG} \end{aligned}$$

(ii)

From (i), we have:

$$\frac{AD}{DG} = \frac{CF}{FG}$$

$$\angle DGF = \angle AGC \quad (\text{Common})$$

$$\therefore \triangle DFG \sim \triangle ACG \quad (\text{SAS similarity})$$

### Question 30.

i.

In  $\triangle PQR$  and  $\triangle SPR$ ,

$$\angle PSR = \angle QPR \dots \text{given}$$

$$\angle PRQ = \angle PRS \dots \text{common angle}$$

$$\Rightarrow \triangle PQR \sim \triangle SPR \quad (\text{AA Test})$$

ii. Find the lengths of QR and PS.

Since  $\triangle PQR \sim \triangle SPR$  ... from (i)

$$\Rightarrow \frac{PQ}{SP} = \frac{QR}{PR} = \frac{PR}{SR} \dots (a)$$

$$\frac{QR}{PR} = \frac{PR}{SR} \quad \dots \text{from (a)}$$

$$\Rightarrow \frac{QR}{6} = \frac{6}{3}$$

$$\Rightarrow QR = \frac{6 \times 6}{3} = 12 \text{ cm}$$

$$\frac{PQ}{SP} = \frac{PR}{SR} \quad \dots \text{ from (a)}$$

$$\Rightarrow \frac{8}{SP} = \frac{6}{3}$$

$$\Rightarrow SP = \frac{8 \times 3}{6} = 4 \text{ cm}$$

iii.

$$\frac{\text{area of } \triangle PQR}{\text{area of } \triangle SPR} = \frac{PQ^2}{SP^2} = \frac{8^2}{4^2} = \frac{64}{16} = 4$$