

## ACTIVITIES

# ACTIVITY

# 1

## A<sub>IM</sub>

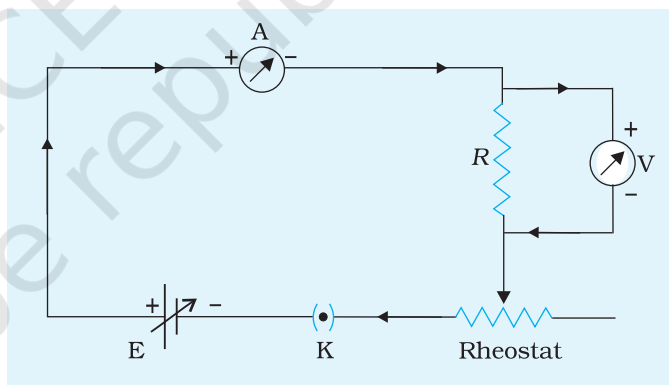
To assemble the components of a given electrical circuit.

## A<sub>PPARATUS AND MATERIAL REQUIRED</sub>

Resistor, ammeter, (0-1.5A) voltmeter (0-5V), battery, one way key, rheostat, sand paper, connecting wires.

## P<sub>ROCEDURE</sub>

1. Connect the components as shown in Fig. A 1.1.
2. After closing the key K, check that the voltmeter and ammeter show deflections on the right hand side.
3. Check the continuity of the assembled circuit using a multimeter (see Activity 4).



**Fig. A 1.1** Assembling of given components

## R<sub>ESULT</sub>

The components of the electrical circuit were assembled.

## P<sub>RECAUTIONS</sub>

1. The positive terminal of the battery should be connected to the positive terminal of ammeter and positive terminal of the voltmeter.
2. The ammeter should be connected in series with the resistor and the voltmeter should be connected in parallel with the resistor.
3. Sand paper should be used to clean the ends of connecting wires and leads of the component terminals. Grease/oil or oxide layer

on their surfaces is insulating in nature and needs to be removed. However, do not clean the plugs and keys with sand paper. Excessive use of sand paper in such a case will make the plug unfit to be used with the key.

## DISCUSSION

1. Draw the circuit diagram of the experiment before you start connecting apparatus and keep in front of you.
2. The values of the resistances and the current carrying capacity of the rheostat are given on a plate fixed on the body of rheostat.

## SELF ASSESSMENT

1. What do you mean by emf of a cell?
2. Does the current drawn from the cell remain constant? If not, why?
3. Why is an ammeter always connected in series with the circuit?
4. Why is a voltmeter always connected in parallel to the component across which voltage is to be measured?

## SUGGESTED ADDITIONAL EXPERIMENTS/ACTIVITIES

1. Design different kinds of circuits that you will study in your class and assemble them using the relevant components, for example (i) circuit to measure the value of an unknown resistance using a meter bridge (ii) circuit to compare e.m.f. of two cells using a potentiometer, etc.
2. Measure the voltmeter and ammeter readings for different rheostat settings and verify if the ratio of potential difference across the resistor to the current through it is constant.
3. Modify the circuit using two resistors which may either be connected in series or in parallel.

## ACTIVITY 2

### AIM

To draw the diagram of given open circuit comprising at least a battery, resistor/rheostat, key, ammeter and voltmeter. Mark the components that are not connected in proper order and correct the circuit and also the circuit diagram.

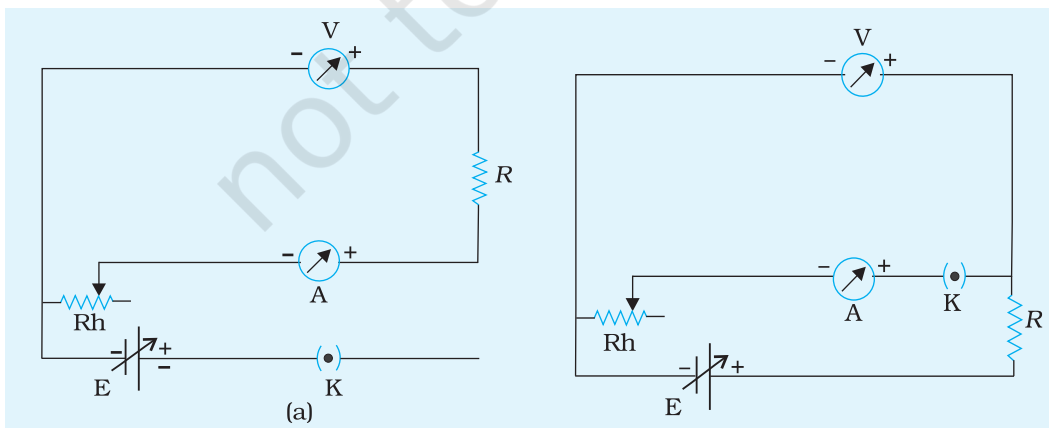
### APPARATUS AND MATERIAL REQUIRED

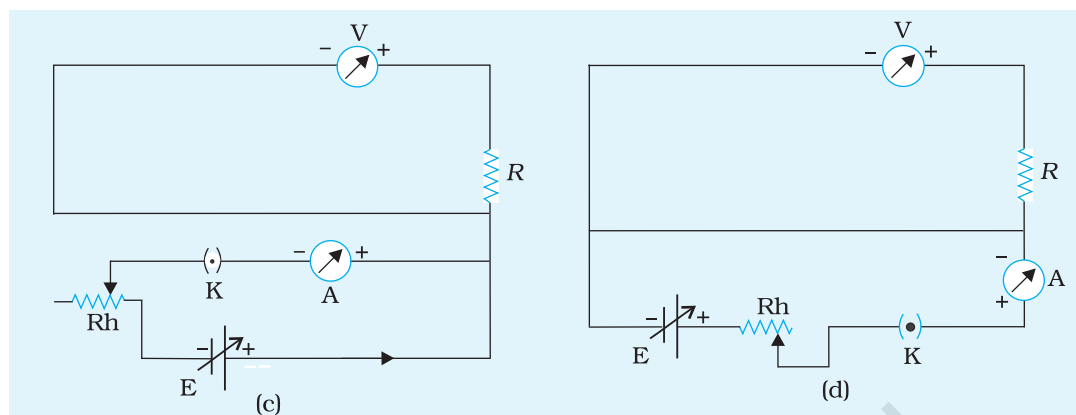
A given open circuit comprising atleast a cell or a battery, plug key, resistor, rheostat, ammeter, voltmeter, connecting wires and sand paper.

### PRINCIPLE

An electrical circuit is functional only if all the components of the circuit are connected in proper order, assuming that all circuit components/devices are in working condition and key is closed.

An open circuit means a break in some part of a circuit which could be deliberate such as a key in open position or a fault such as broken wire or burnt out component(s) or loose connection. Some of such circuits are given in Figs. A 2.1 (a), (b), (c) and (d).





**Fig. A 2.1 (a),(b),(c),(d)** Open circuits

**Note to teachers:** In this activity, students are expected to draw the diagram of a given open circuit comprising a few circuit components e.g. a key, ammeter, voltmeter, resistor, rheostat etc. After drawing the given circuit, students would be marking the components which are not connected in proper order. Then a correct circuit diagram is to be drawn and accordingly the circuit components are to be connected in proper order.

Teachers are therefore advised to set up a few open circuits in which some of the components are not arranged in proper order.

## PROCEDURE

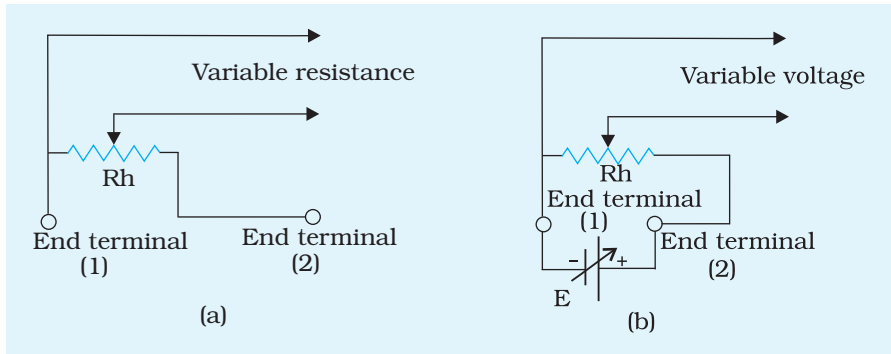
1. Draw the circuit diagrams in your notebook as given by your teacher [Fig. A 2.1 (a), (b), (c) and (d)].
2. Consider one circuit and mark in Table A 2.1, the various components which have not been connected in proper order.
3. Draw the correct circuit diagram.
4. Connect the electrical components according to corrected circuit diagram.
5. Close the key in the circuit to verify if the corrected circuit is functional.

**Note:** Rheostat can be used both as a variable resistance and potential divider.

### Rheostat as a variable resistance

1. Draw a diagram as given in Fig. A 2.2 (a) showing use of a rheostat as a variable resistor.

- Connect the terminals of rheostat as drawn below using one end terminal and the other variable terminal.



**Fig. A 2.2** (a) Rheostat as a variable resistor  
 (b) Rheostat as a potential divider giving variable voltage

### Rheostat as a potential divider

- Draw a diagram as given in Fig. A 2.2 (b) showing use of a rheostat as a potential divider.
- Connect the terminals of rheostat as drawn above using (i) the end terminals (1) and (2) connected to input potential (battery) and (ii) one end terminal and the other variable terminal for variable voltage.

## OBSERVATIONS

**Table A 2.1: Mark a (✓) in appropriate column**

Sl. No.	Circuit Component	Correct Connection	Incorrect Connection
1	Battery/cell		
2	Resistor		
3	Rheostat		
4	Key		
5	Ammeter		
6	Voltmeter		

## RESULT

The electrical circuit assembled as per the corrected circuit diagram is functional.

## PRECAUTIONS

1. Ends of the connecting wires should be cleaned with sand paper before making connections.
2. The positive terminal of the battery should be connected to the positive terminal of the voltmeter and positive terminal of the ammeter.
3. The ammeter should be connected in series with the resistor and the voltmeter should be connected in parallel with it.

## DISCUSSION

1. (a) Rheostat can be used in series as a variable resistance. In this case, the end terminal (1) and the other variable terminal is to be used [Fig. A 2.2(a)].  
 (b) When rheostat has to be used as a potential divider across the cell, the variable voltage is derived using any one end-terminal and the variable terminal of the rheostat [Fig. A 2.2(b)].

Justify how the discussion points 1(a) and 1(b) are possible?

2. Key is to be kept "OPEN" so that no damage to the components occur.

## SELF ASSESSMENT

1. Interpret the function of each component in the circuit.
2. Draw a circuit diagram of a rheostat as a variable resistance showing the position of sliding contact for (i) maximum resistance (ii) minimum resistance.
3. What is the function of sand paper in setting up the electric circuit?
4. A rheostat and a resistance box can change the resistance in a circuit, yet their functions are different. Discuss it.

### SUGGESTED ADDITIONAL EXPERIMENTS/ACTIVITIES

1. Draw a circuit diagram using rheostat as a potential divider. Make actual connection and determine the voltage range it provides.
2. Study the different kinds of keys available in the laboratory and identify their functions in the electric circuit.
3. Make a detailed study of different types of resistances available in the laboratory (carbon resistor, wire wound resistance box).
4. Compare the connecting wires used in household circuits and those used in the laboratory.
5. Make a study of different battery eliminators, dc sources (cells, batteries) in the laboratories. How are they different as compared to car batteries?

## A<sub>IM</sub>

To measure the resistance and impedance of an inductor with or without iron core.

## A<sub>PPARATUS AND MATERIAL REQUIRED</sub>

Inductor coil (diameter about 2 cm and 2000 turns), soft iron core (cylindrical rod of diameter about 1.75 cm and length equal to that of inductor), resistance box (0 to 10,000 ohm), battery eliminator (0-2-4-6 volt), a step down transformer with tapings (0-2-4-6 volt, 50 Hz), dc milliammeter (range 0 - 500 mA), ac milliammeter (range 0 - 500 mA), dc voltmeter (range 0 - 5 V), ac voltmeter (range 0 - 5 V), one way key, connecting wires.

## P<sub>RINCIPLE</sub>

An inductor is a cylindrical coil of very large number of turns of copper wire usually wound on a hollow cylinder. The resistance of such coil is given as

$$R = \frac{V}{I} \quad \text{(A 3.1)}$$

where  $V$  is the potential difference across the coil and  $I$  is the dc current through that coil. On introducing the core of soft iron, the new values of potential difference across the coil,  $V'$  and the current,  $I'$  through it are measured again. The resistance of the coil with iron core becomes

$$R' = \frac{V'}{I'} \quad \text{(A 3.2)}$$

The resistance offered by the coil to the flow of alternating current is known as impedance  $Z$ . If  $V_{ac}$  and  $I_{ac}$  respectively be the alternating voltage and alternating current through the coil, without iron core, then the impedance of the coil, is given as

(A 3.3)

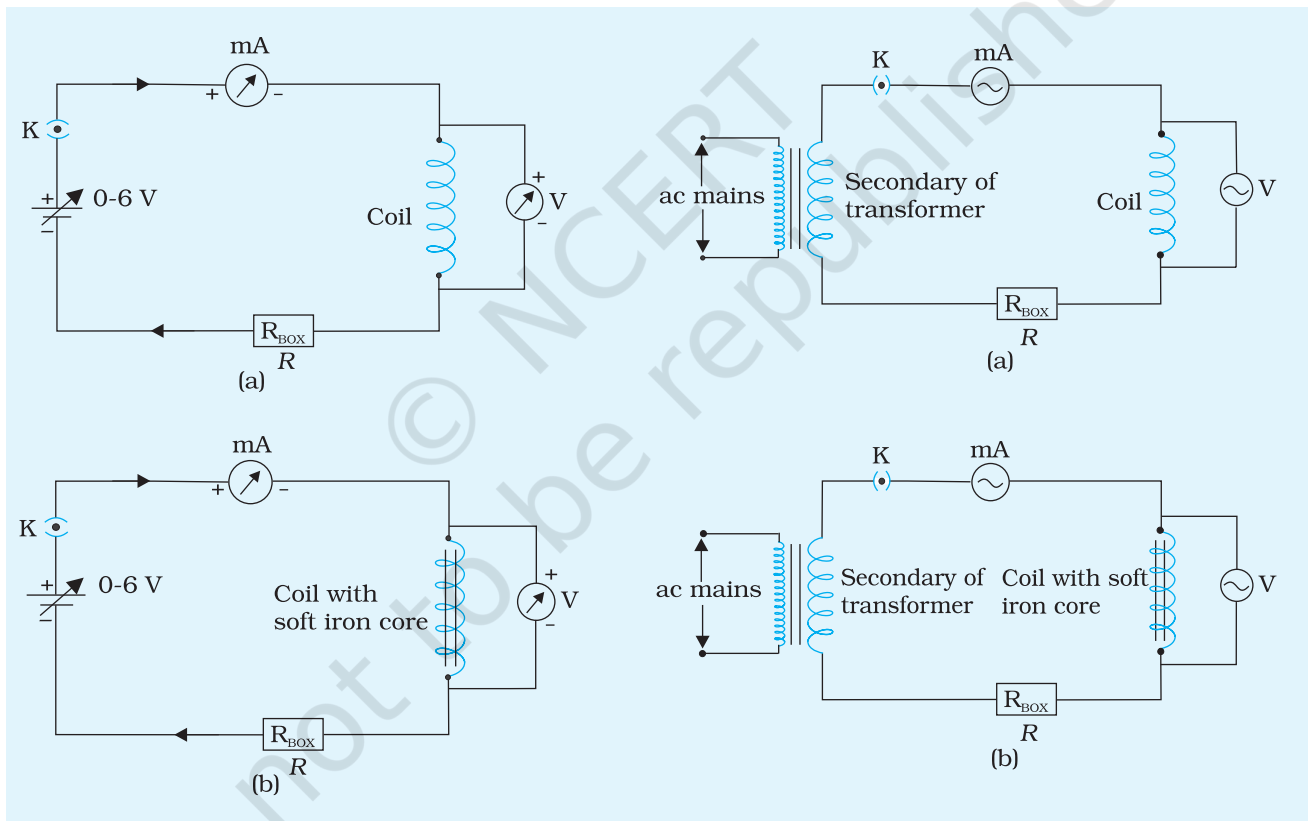
$$Z = \frac{V_{ac}}{I_{ac}}$$

On introducing the iron core inside the coil, the value of the impedance  $Z'$  becomes

(A 3.4)

$$Z' = \frac{V'_{ac}}{I'_{ac}}$$

where,  $V'_{ac}$  is the alternating voltage across the inductor with core inside and  $I'_{ac}$  is the alternating current through the inductor with core inside.



**Fig. A 3.1** Inductor in a dc circuit: measurement of resistance with (a) an air core (b) a soft iron core

**Fig. A 3.2** Inductor in an ac circuit: measurement of impedance with (a) air core (b) soft iron core.



## PROCEDURE

1. **For resistance of inductor without iron core**, arrange the apparatus as per the circuit diagram Fig. A 3.1 (a) by keeping the key K open.
2. Connect the dc source and dc milliammeter in series with inductor and voltmeter in parallel with it.
3. Adjust the battery eliminator to the lowest setting and switch on the eliminator. Plug in the key. Adjust  $R$  so that the readings are within scale. Measure the dc current and dc voltage across the inductor.
4. Set the eliminator to higher voltages in succession and record the dc current and dc voltage across the inductor.
5. **For resistance of inductor with soft iron core**, introduce the iron core such that it is fully inside the coil. [Fig. A 3.1(b)].
6. Repeat steps 3 and 4 and record the current and voltage across the inductor.
7. **For measurement of impedance of inductor without iron core**, use step down transformer with various tapings (2V, 4V, 6V), ac voltmeter (0-5V) and ac ammeter (0-0.3A) and connect them as shown in Fig. A 3.2(a).
8. Repeat steps 3 and 4 and for alternating current and alternating voltage. Record the current and voltage across the inductor.
9. **For measurement of impedance of inductor with soft iron core**, introduce the core of the soft iron inside the coil such that the core is fully inside the coil. [Fig. A 3.2(b)].
10. Repeat steps 3 and 4 for alternating current and alternating voltage. Record the current and voltage across the inductor.

## OBSERVATIONS

1. Range of dc voltmeter = 0 to...V
2. Least count of dc voltmeter = ...V
3. Range of dc ammeter = 0 to...mA
4. Least count of dc ammeter = ...mA
5. Range of ac voltmeter = 0 to...V
6. Least count of ac voltmeter =...V
7. Range of ac ammeter = 0 to...mA
8. Least count of ac ammeter =...mA

**Table A 3.1: Resistance of the inductor without and with iron core**

Sl. No.	Battery Eliminator Setting	Without iron core			With iron core		
		Voltage	Current	$R = \frac{V}{I}$	Voltage	Current	$R' = \frac{V'}{I'}$
		V (V)	I (mA)	R (Ω)	V' (V)	I' (mA)	R' (Ω)
1							
2							
3							
4							
			Mean		Mean		

**Table A 3.2: Impedance of the coil without and with iron core**

Sl. No.	Setting of ac voltage source	Without iron core			With iron core ac voltage		
		Voltage	Current	$Z = \frac{V}{I}$	Voltage	Current	$Z' = \frac{V'}{I'}$
		V (V)	I (mA)	Z (Ω)	V' (V)	I' (mA)	Z' (Ω)
1							
2							
3							
4							
			Mean		Mean		

### CALCULATIONS

1. Calculate the ratio of voltage and current for each observation to get resistance and impedance.
2. Calculate the mean values of the resistance and impedance in each case, i.e., without and with iron core.

### RESULT

1. The dc resistance of the inductor coil without iron core = ...Ω
2. The dc resistance of the inductor coil with iron core = ...Ω
3. The impedance of the inductor coil without iron core = ...Ω
4. The impedance of the inductor coil with iron core = ...Ω

## PRECAUTIONS

1. The ammeter should be connected in series with the coil and the voltmeter in parallel with it.
2. The iron core should be inserted completely within the coil.
3. The ends of the connecting wires should be cleaned with sand paper before making the connections.

## SOURCES OF ERROR

The least count of the ac milliammeter and ac voltmeter may not be small enough to accurately record the difference in impedance on inserting the iron core.

## SELF ASSESSMENT

1. What is meant by impedance of a circuit?
2. What differences do you observe in dc and ac ammeters and voltmeters?
3. If iron core of the inductor coil is taken out, what effect will it have on the readings of the ammeter and voltmeter and why?

## DISCUSSION

1. Compare the dc resistance of the coil with and without iron core. It will be found that there is no change in the resistance of the coil on introduction of iron core. Explain the result.
2. Compare the impedance of the coil with and without iron core. It will be observed that the impedance increases on introduction of iron core. Explain the result.

### SUGGESTED ADDITIONAL EXPERIMENTS/ACTIVITIES

1. Repeat the ac measurement with wooden, plastic or copper cores (which may have any length). Do you see any change in impedance on introduction of such cores?
2. If the iron core is not fully inside, do you get the same change in impedance?

## AIM

To measure resistance, voltage (dc/ac), current (dc) and check continuity of a given circuit using a multimeter.

## APPARATUS AND MATERIAL REQUIRED

A multimeter with its test leads, a resistance box, a key, a cell, a step-down transformer of 6 V output voltage, a rheostat, connecting wires and a piece of sand paper.

**(Note to teachers:** Do not allow students to handle alternating current sources of 220 V for safety considerations.)

**Description of multimeter:** A multimeter is an instrument that can work as a current meter (ammeter) or a voltage meter (voltmeter) or a resistance meter (ohmmeter). Sometimes it is also referred to as AVO (ampere, volt and ohm) meter. It may measure resistance and potential difference in both ac and dc circuits and current in dc circuit over several ranges. The function and the range can be selected by means of either a rotary selector knob or a combination of switches and sockets.

Multimeters are of two kinds : analog and digital.



**Fig. A 4.1(a)** Analog multimeter

**Analog multimeter :** Analog multimeter Fig. A 4.1 (a) is a dc galvanometer which can be converted into an ammeter or a voltmeter of different ranges to measure current or voltage or resistance. For ac measurement, the root mean square (*rms*) values of current and voltage are measured.

When using a multimeter to measure current, it must be connected in series with the circuit. For measuring the voltage difference between two points in a circuit, the two leads of the multimeter are connected across them. For example, to measure the voltage across a resistor, the multimeter is connected in parallel with the resistor.

When the multimeter is in the resistance measuring mode, a cell within the multimeter automatically gets connected, which makes the current flow through the externally connected resistor whose resistance is being measured. The multimeter only senses

this current with its dial calibrated in terms of the resistance. It is essentially nonlinear in calibration.

**Digital multimeter :** Fig. A 4.1(b) shows a digital multimeter.

To measure voltage and current it uses a digital circuit called ADC (analog to digital converter). Since the ADC can accept a very small input voltage, a sampling of the input voltage/ current is necessary.

Voltage is measured directly, whereas current is converted into proportional voltage using standard resistors built in the instrument.

For resistance measurement, constant current sources are used. It creates voltage proportional to resistance values which is then digitised by the ADC.

The resolution of such meters depends on the range as well as the number of digits in the display panel.



**Fig. A 4.1(b)** Digital multimeter

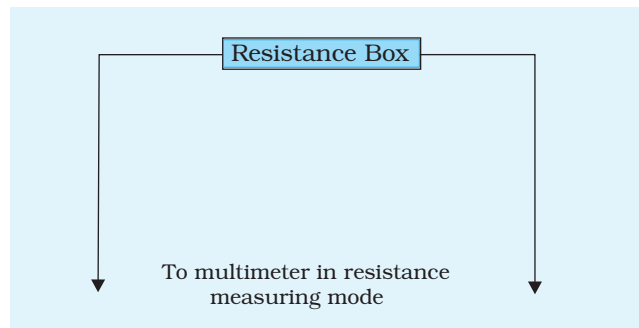
## P RINCIPLE

When the resistance  $R$  is connected in a circuit, for example as shown in Fig. A 4.2, the potential difference across the two end points of the resistor can be measured by connecting the multimeter (with proper voltage setting) in parallel with the resistor.

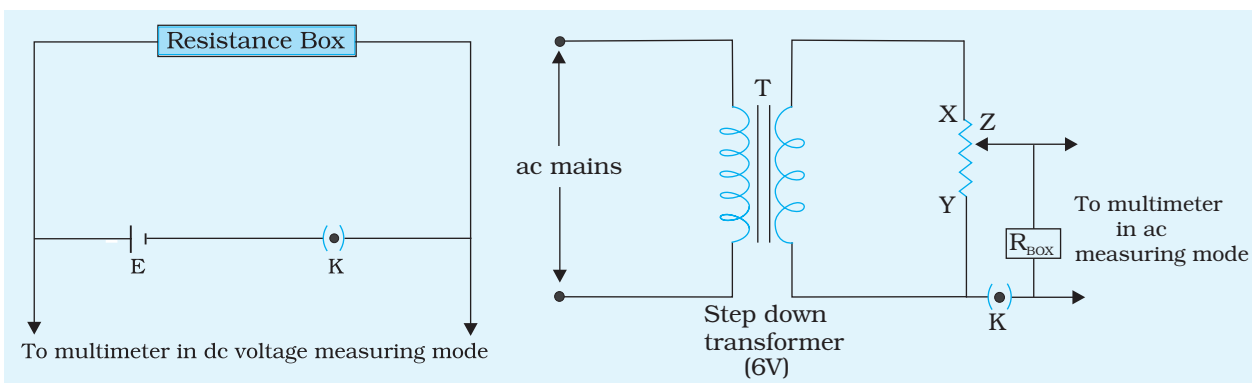
The coil of the multimeter shows a deflection proportional to the direct current (dc) passing through it. Measurement of alternating current is based on the principle of heating effect of current.

The current flowing through the resistor can be measured by connecting the multimeter (with proper current setting) in series as shown in Fig. A 4.5.

The continuity of any electrical component can be checked by measuring the resistance of the component. An infinite resistance across the two ends of a component

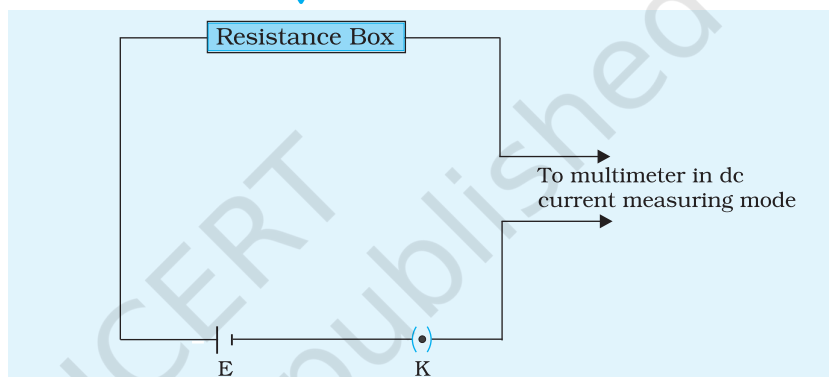


**Fig. A 4.2** Use of multimeter as a resistance meter



**Fig. A 4.3** Use of multimeter as a dc voltmeter

**Fig. A 4.4** Use of multimeter as ac voltmeter



**Fig. A 4.5** Use of multimeter as an ammeter

indicates a discontinuity. A very low resistance ( $\leq 0.1 \Omega$ ) between the two ends of a component indicates that the component under test has a short circuit. (Fig. A 4.2).

## PROCEDURE

### Analog multimeter

1. Clean the ends of connecting wires by a sand paper till they shine. Preferably, use fresh connecting wires, as wires not in use for long may have some insulating layer deposited on them. Also check that the metallic ends of the multimeter test leads are not having any rust or any insulating layer deposited on them.
2. **For measurement of resistance:** set the multimeter in resistance measuring mode. Connect the red and black probes to the multimeter.
3. Connect open end of the red probe directly to the black probe and adjust the zero adjustment knob to read zero ohm on the resistance scale (extreme right).
4. Separate the two metallic ends of the test probes and connect the resistance box with the multimeter as shown in Fig. A 4.2.

5. Insert a resistor of known resistance  $R$  in the circuit by taking out the corresponding resistor key from the resistance box and read multimeter reading  $R_M$  for the value of resistance of the resistor used in the circuit. Repeat this step for four more resistors.
6. Carefully observe the reading in the non-linear scale noting that its zero lies at the extreme right of the scale. Use the multiplication factor appropriately to the range selected.  
For example: 4 divisions of deflection in  $R \times 100$  scale means resistance measured is  $4 \times 100\Omega = 400\Omega$ .
7. **For measurement of dc voltage:** select the suitable position of the function switch (ac/dc) and then select the highest range available. Ensure that the test probes are inserted/ connected in sockets with proper polarity. It is a convention to use red probe for positive and black probe for negative polarity.
8. Connect the multimeter in the circuit as shown in Fig. A 4.3.
9. Set the multimeter to measure the dc voltage. Select a suitable range. For example, if a cell of 1.5V emf (say) is used in the circuit, keep the range at 2.5V.
10. To measure the emf of the cell, connect the positive terminal of the multimeter to the positive terminal of the cell and negative terminal to negative terminal of the cell, through a plug key K. Do not insert any resistor of resistance  $R$  in the circuit from the resistance box. Insert the key in the plug K of the circuit and read the multimeter reading. (A continuous flow of current in the circuit will heat the connecting wires). Record your observations in Table A 4.2. Then open the key K.
11. Now insert a resistance  $R$  of known value (10  $\Omega$  say) by taking out the resistance key from the resistance box in the circuit. Insert the key in the plug K. Read the multimeter reading for measuring the potential difference across the two ends of the resistor. Do you find any change in the reading as observed in step 10 when there was no resistance in the circuit (i.e.  $R = 0$ )?
12. Repeat step 11 for three more values of resistance in the circuit. Record your observations in Table A 4.2.
13. **For measurement of ac voltage:** connect an ac step down transformer of 6 V output voltage, a rheostat XY as voltage divider, resistance box  $R_{\text{BOX}}$ , a plug key K, and the multimeter as shown in Fig. A 4.4. Fix the value of  $R$  to be 5 ohm (say).
14. Set the multimeter to act as an ac voltmeter at 10V range.
15. Bring the variable connector Z of the rheostat close to point X. In this situation the resistance of rheostat coil would be minimum. Close the key in the plug K and record the multimeter reading for ac voltage drop across the resistor of resistance  $R$  in Table A 4.3. Repeat the observations for atleast four positions of the variable connection (Z) of the rheostat on coil XY (Table A 4.3).

**Note to students:** Please do not handle alternating current sources of 220 V for safety considerations.

16. **For measurement of dc current:** select the function switch and the range switch/sockets suitable for proper dc current measurement. For example, if one cell of 1.5 V emf is used in the circuit as a source and the value of resistance to be used during the experiment varies from  $2\ \Omega$  to  $10\ \Omega$ , a range of 1A (or 1000 mA) would be appropriate.
17. Insert the probes of the multimeter in series with the cell so that the positive terminal of the multimeter is connected to the positive terminal of the cell and negative terminal of the multimeter with the negative terminal of the cell as shown in Fig. A 4.5.
18. Read the multimeter reading for measuring the dc current flowing through the multimeter.
19. Bring a resistance ( $R$ ) in the circuit and read multimeter reading for measuring the current flowing in the circuit after closing the key in plug K. Repeat it for four more values of resistance ( $R$ ) in the circuit. Record the observations in Table A 4.4.

#### Digital multimeter

Procedure for measuring voltage, current and resistances is very similar to that of the analog measurement. The notable difference is that digital multimeter is not vulnerable to damage as easily as their analog counterparts. They can accept voltage with reversed polarities (shown by positive and negative sign), and display the number as and when the magnitude of the measured quantity crosses the upper limit of the range used.

There are no adjustments required (on any of the ranges) for measuring  $R$ .

## OBSERVATIONS

1. Range of resistance scale on the multimeter panel =...  $\Omega$
2. Least count of the scale =...  $\Omega$

**Table A 4.1 : Measurement of resistance**

Sl. No.	Resistance $R$ as indicated in resistance box ( $\Omega$ )	Multimeter reading $R_M$ ( $\Omega$ )	Difference $R - R_M = [ R - R_M ]$ ( $\Omega$ )
1			
2			
--			
5			



Range of dc voltage scale selected on the multimeter panel = ... V

Least count of the scale = ... V

**Table A 4.2 : Measurement of dc voltage**

Sl. No.	Resistance $R$ in the circuit ( $\Omega$ )	Multimeter reading for voltage (V)
1		
2		
--		
5		

Range of ac voltage scale selected on the multimeter panel = ...V

Least count of the scale = ...V

**Table A 4.3 : Measurement of ac voltage drop across a resistor of resistance  $R = \dots\Omega$**

Sl. No.	Position of variable connection Z of the rheostat on coil XY	Multimeter reading (V)
1	Close to point X	
2		
--		
5	Close to point Y	

Range of dc current scale selected on the multimeter panel = ... mA

Least count of the scale = ... mA

**Table A 4.4 : Measurement of dc current**

Sl. No.	Resistance $R$ in the circuit ( $\Omega$ )	Multimeter reading for current (mA)
1		
2		
--		
5		

## RESULT

1. The dc/ac voltage, dc current and resistance have been measured using a multimeter.

2. The values of resistance measured by the multimeter is nearly the same as the decoded values of resistors.

## PRECAUTIONS

1. Appropriate selection of function switch and range switch for a given measurement of voltage or current and resistance should be made.
2. The polarity probe leads should be connected to the proper polarities in measuring dc voltage and current.

## SOURCES OF ERROR

1. The scale used in reading of voltage/ current may be improper.
2. Zero adjustment in measuring  $R$  with analog multimeter may not be accurate.

## DISCUSSION

1. If in place of a resistance box, carbon resistors are used, the heating of carbon resistor should be avoided. Heating of resistors may change the resistance value of the resistor.
2. The percentage error in the measurement is more for smaller values of the measured quantity.
3. If the two test leads of the multimeter are not identical, and also there is significant resistance across the junctions of the multimeter (test leads and the test resistance), how is your measurement going to be affected?

## SELF ASSESSMENT

Can the measurement of dc voltage/ current be done using ac voltage/ current function switch? Justify your answer.

### SUGGESTED ADDITIONAL EXPERIMENTS/ACTIVITIES

A collection of assorted colour coded resistors are provided to you. Verify the decoded values using multimeter within the tolerance limit specified by the code on the resistor.

## AIM

To assemble a household circuit comprising three bulbs, three (on/off) switches, a fuse and a power source.

## APPARATUS AND MATERIAL REQUIRED

Three bulbs (40 W, 220 V each), three (on/off) switches, socket, a fuse of 1.0 A, plug, flexible connecting wire, main switch.

## PRINCIPLE

If  $P_1, P_2, P_3, P_4, P_5, \dots$  be the power consumed by different domestic electrical appliances in a circuit then the total power consumption,  $P$  at any instant is given by

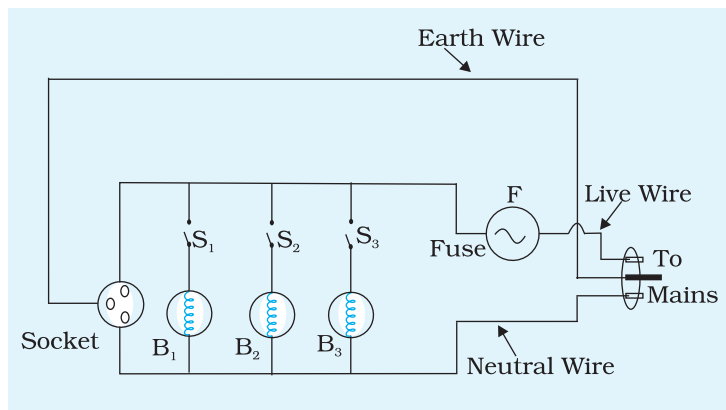
$$P = P_1 + P_2 + P_3 + P_4 + P_5 + \dots \quad \text{(A 5.1)}$$

If electric potential is  $V$ , then current  $I$  drawn from the mains is given by

$$I = \frac{P}{V} \quad \text{(A 5.2)}$$

where  $P$  is in watt,  $V$  in volt and  $I$  in ampere.

In order to protect the appliances from damage, when accidentally a high current is drawn (e.g. when the terminals of the appliance get accidentally connected), a fuse of rating little higher (10 to 20 per cent higher than the current normally drawn) is connected in series with the set of appliances (Fig. A 5.1).



**Fig. A 5.1**

## PROCEDURE

1. Take the bulbs  $B_1$ ,  $B_2$ ,  $B_3$  and connect them in series with switches  $S_1$ ,  $S_2$  and  $S_3$  respectively. Connect  $B_1$ ,  $B_2$ ,  $B_3$  along with  $S_1$ ,  $S_2$ ,  $S_3$  in parallel with each other as shown in Fig. A 5.1.
2. Connect fuse F in series with the set up as shown in Fig. A 5.1. Connect a plug and the socket at the end of two leads. Connect a wire from the earth pin of the plug.
3. Insert the plug in socket provided in the main electric board.
4. Press the switches  $S_1$ ,  $S_2$ ,  $S_3$  one by one and observe the bulb that is switched on and off independently of the other bulb.
5. Press all the switches simultaneously and observe what happens. Record your observations.

## RESULT

Household circuit assembly is complete and installed with safety.

## PRECAUTIONS

1. Care should be taken while working with mains.
2. Carefully determine the rating of the fuse by calculating the maximum current drawn by the circuit.

## DISCUSSION

1. Fuse is a safety device. Never use fuse of much higher rating than the recommended value.
2. The rating of the main electricity in our houses is determined by the total power requirements. In general it is 220 V, 30 A and 50 Hz. The supply is connected to a distribution board which divides the power into different circuits; some having a rating of 220 V, 15 A meant for heavy duty appliances like room heater, airconditioner, geysers, hot plates etc., others have a rating of 220 V, 5 A meant for light appliances like light bulbs, ceiling fans etc. Let us consider one electrical circuit with 220 V, 5 A supply. In such a circuit all appliances are connected in parallel with a switch. This switch is in series with each appliance in supply live line.

## SELF ASSESSMENT

1. Calculate the maximum current drawn for three bulbs used in the circuit.

### SUGGESTED ADDITIONAL EXPERIMENTS/ACTIVITIES

1. Draw a circuit diagram consisting of two light points, one fan point and one plug point.

## AIM

To study the variation in potential drop with length of a wire for a steady current.

## APPARATUS AND MATERIAL REQUIRED

Potentiometer, battery eliminator of constant voltage, dc power supply or lead accumulator, voltmeter and ammeter of suitable range, plug key, jockey, rheostat, connecting wires, etc.

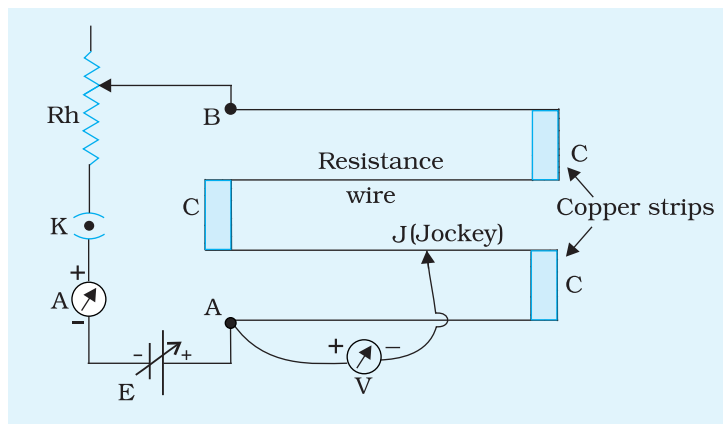
## PRINCIPLE

If a steady current is flowing through a wire of uniform area of cross section and having its resistance per unit length constant, potential drop  $V$  across two points of the wire is directly proportional to the length  $l$  between those two points.

Mathematically,  $V \propto l$

## PROCEDURE

1. Set up the electrical circuit as shown in Fig. A 6.1.
2. Connect positive terminal of the battery to point A (zero length) of the potentiometer.
3. Connect negative end of the battery through an ammeter, plug key and a rheostat. The ammeter



**Fig. A 6.1** Circuit to study variation in potential drop

should be connected in such a way that its negative terminal is connected to the negative terminal of the battery.

4. Connect positive end of the voltmeter to point A and other end to a jockey J.
5. Now close the key K and press the jockey at point B. Adjust the rheostat to get full scale deflection in voltmeter.
6. When jockey is pressed at point A, you will get zero deflection in the voltmeter.
7. Now press the jockey at 40 cm and note the corresponding voltmeter reading.
8. Repeat your observation by pressing the jockey at various lengths like 80 cm, 120 cm etc. which may extend upto, say 400 cm of potentiometer wire. Record voltmeter reading in each case as shown in Table A 6.1.

## OBSERVATIONS

Range of the voltmeter = ... V

Least count of the voltmeter = ...V

Zero error = ... V

**Table A 6.1: Variation in potential drop with length**

Sl. No.	Length of potential wire over which potential drop is measured $l$ (cm)	Voltmeter reading $V$ (V)	$\phi = V/l$ ( $V\text{ cm}^{-1}$ )
1			
2			
...			
5			
Mean			

## CALCULATIONS

The ratio  $\frac{V}{l} = \phi$  is calculated. It is the potential gradient of the wire.

Its value is almost constant.

## PLOTTING GRAPH

Plot a graph of  $V$  versus  $l$ , with  $V$  on y-axis and  $l$  on x-axis. Slope of the line gives  $\phi$ .

## RESULT

The ratio  $\left(\frac{V}{l}\right)=\phi$  is found to be constant within the limits of experimental error. Its mean value is...  $V\text{ cm}^{-1}$ .

The graph shows a linear relationship between  $V$  and  $l$ . The value of  $\left(\frac{V}{l}\right)=\phi$  from the graph is ...  $V\text{ cm}^{-1}$ .

## PRECAUTIONS

1. Zero error in the voltmeter and ammeter (if there is any) should be corrected by adjusting the screw provided at the base of the needle.
2. The current in the wire should remain constant throughout the experiment. To ensure this, current should be drawn intermittently for short duration of time. It should be monitored by an ammeter and readjusted whenever necessary, with the help of a rheostat.
3. Do not press the wire too hard with the jockey while noting down the observations or else there is a possibility that the wire will become non-uniform (diameter will change) at these points during the course of time.
4. Check for uniformity of wire at its various points before the start of the experiment. If wire is non-uniform, the potential gradient will not be constant.

## SOURCES OF ERROR

1. The wire must have a uniform cross section along its entire length. This should be checked by measuring its diameter at various points before the start of the experiment.
2. Voltmeter may not give accurate reading.

## DISCUSSION

1. The potentiometer wire is connected firmly to thick copper strips after every 100 cm of its length of 400 or 1000 cm. However, these small sections of wire do not contribute to the total length of the potentiometer wire since electrical current flows through the copper strips rather than the potentiometer wire in these sections.

- Potentiometer has the advantage that it draws no current from the voltage source being measured. As such it is unaffected by the internal resistance of the source.
- If the graph is non-linear, what conclusion will you draw?

## SELF ASSESSMENT

- A 100 cm wire of homogeneous material and uniform area of cross-section form a square as shown in Fig. A 6.2. How can this arrangement be used to select voltages  $1/4$ ,  $1/2$ ,  $3/4$  of the voltage across AE.

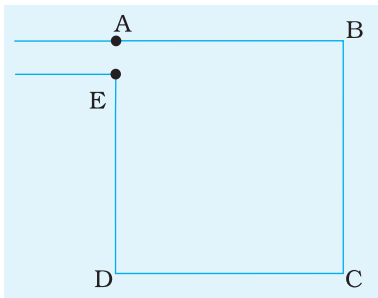


Fig. A 6.2

- A rheostat  $R_h$  used in laboratories along with a key  $K$ , battery of emf  $E$  and internal resistance  $r$  is shown in Fig. A 6.3.  $R_L$  is some load resistance that represents an auxiliary circuit which may be there in reality. If  $D$  is the midpoint of the wire  $AB$ , what would be the voltmeter reading? Does it depend on the value of  $R_L$  or  $R_V$ , if  $R_V$  represents the resistance of the voltmeter? Does it depend on  $r$ ?

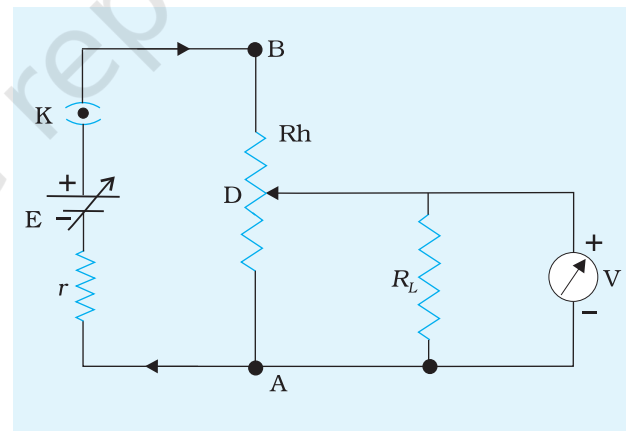


Fig. A 6.3

- Consider a case in the above problem, wherein a potential difference across ends A and B of the wire is 3 V. An experiment requires a potential difference of 1.7 V as precise as possible. Think of the possibilities of reducing emf of the source, using another resistor in series or using a rheostat of the same resistance but of greater length.

Is it possible to get negative potentials using the same circuit? If yes, how?



**SUGGESTED ADDITIONAL EXPERIMENTS/ACTIVITIES**

1. Connect a circuit as shown in Fig. A 6.3. Record potential difference at various length  $l$  from end A. Plot a graph of  $V$  versus  $l$ . Obtain from the graph the length that corresponds to 1.3 V. Draw a circuit diagram to show how you can supply 1.3 V to an auxiliary circuit that works at 1.3 V.
2. A small circuit called the 'level indicator' (popularly known as dancing LED's) is available in the entertainment electronics market. It is often used in stereophonic two-in-one recorders or graphic equalisers. Connect such a circuit in place of a voltmeter in this activity and estimate the voltage levels at which the LED's in the array glow one after another.

© NCERT  
not to be republished