

# PHYSICS

## Paper – 1

(THEORY)

(Three hours)

(Candidates are allowed additional 15 minutes for **only** reading the paper.  
They must NOT start writing during this time)

-----

Answer **all** questions in **Part I** and **six** questions from **Part II**, choosing **two** questions from **each** of the Sections **A, B** and **C**.

All working, including rough work, should be done on the same sheet as, and adjacent to, the rest of the answer.

The intended marks for questions or parts of questions are given in brackets [ ].

(Material to be supplied: Log tables including Trigonometric functions)

A list of useful physical constants is given at the end of this paper.

-----

### PART I

Answer all questions

#### Question 1

[5]

A. Answer **all** questions by choosing the correct option A, B, C or D.

- (i) Three identical point charges, each of  $Q$  Coulomb, are kept at the three vertices of an equilateral triangle having each side =  $a$ . [See figure 1]. Electro-static potential energy of the system is:

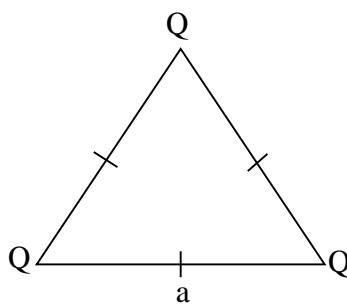

Figure 1

- (A)  $\frac{1}{4\pi\epsilon_0} \frac{Q^2}{a}$       (B)  $\frac{1}{4\pi\epsilon_0} \frac{3Q^2}{a}$       (C)  $\frac{1}{4\pi\epsilon_0} \frac{3Q^2}{a^2}$       (D)  $\frac{1}{4\pi\epsilon_0} \frac{Q^2}{a^2}$
-

- (ii) Four cells  $E_1$ ,  $E_2$ ,  $E_3$  and  $E_4$  are connected as shown in Figure 2. Emf of the battery so formed is:

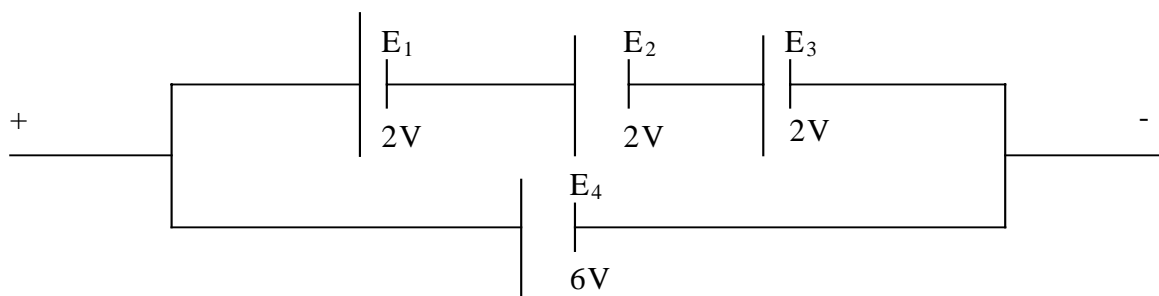

Figure 2

- (A) 6V                      (B) 12V                      (C) 4V                      (D) Zero
- (iii) A  $50 \Omega$  non-inductive resistor is connected to a source which generates an emf  $e$  which is given by
- $e = 200 \sin(120 \pi t)$  Volt. Peak value of current flowing through the resistor is:
- (A) 0.25 A                      (B) 2.5 A                      (C) 4.0 A                      (D)  $4\sqrt{2}$  A
- (iv) A thin converging lens of focal length 25 cm is kept in contact with a thin diverging lens of focal length 20 cm. Focal length of the combination is:
- (A) + 100 cm                      (B) -100 cm                      (C) 45 cm                      (D) 5 cm
- (v) Photo electric threshold wavelength of a certain metal is 198 nm. Its work function is:
- (A)  $1 \times 10^{-18}$  J                      (B)  $1 \times 10^{-19}$  J                      (C)  $1 \times 10^{-16}$  J                      (D)  $1 \times 10^{-17}$  J

**B. Answer all questions briefly and to the point:**

**[15]**

- (i) An oil drop weighing  $1 \times 10^{-15}$  N and carrying a charge of  $8 \times 10^{-19}$  C is found to remain at rest in a uniform electric field of intensity 'E'. Find 'E'.
- (ii) Which conservation principle is involved in Kirchoff's second law?
- (iii) State any one difference between Joule effect and Peltier's effect.

- (iv) Two thin, infinitely long conductors, X and Y, carrying currents  $I_1$  and  $I_2$  are kept parallel to each other, at a distance 'a', in vacuum [See figure 3].

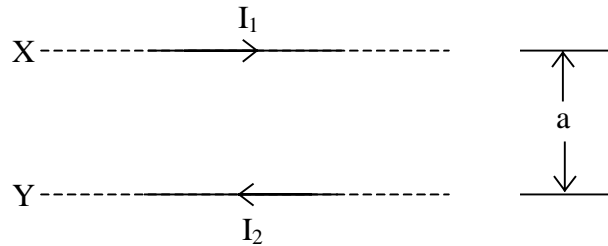

Figure 3

How much force acts on a 1m span of wire Y due to current flowing through X?

- (v) Alternating current  $I$  flowing through a device lags behind the potential difference  $V$  across it by  $90^\circ$  or  $\frac{\pi}{2}$  radian. Is this electrical device a resistor, an inductor or a capacitor?
- (vi) An electro magnetic wave has a frequency of 1 MHz. On which part of the electro magnetic spectrum does this wave lie?
- (vii) What kind of source produces a cylindrical wave front?
- (viii) Plot a labelled graph showing variation of relative intensity with respect to distance, in a single slit diffraction experiment.
- (ix) State any one method by which chromatic aberration produced by a convex lens can be minimized.
- (x) Give any one reason why giant telescopes all over the world are of reflecting type.
- (xi) Figure 4 below is a graph showing variation of relative intensity  $I$  of X rays Vs its wavelength  $\lambda$ , when X ray tube is operated at a tube potential of 20 KV.

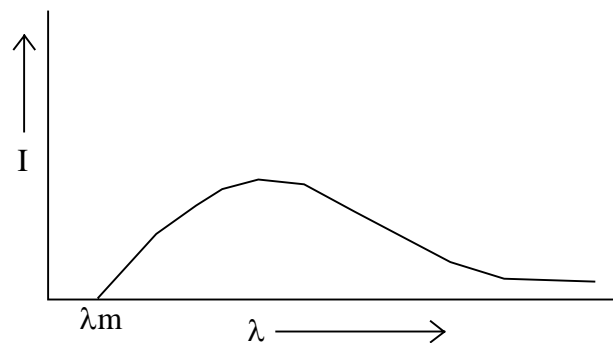

Figure 4

Redraw this graph in your answer book and on same axes, draw another such graph when tube potential is raised to 30 KV.

- (xii) Write down the relation between mean life  $\tau$  of a radioactive substance and its half life  $T_{1/2}$ .
- (xiii) According to the modern view, matter and energy are inter-convertible. Give one example where energy is converted to matter.
- (xvi) Draw graphs to show input and output voltages of an ideal amplifier.
- (xv) Write down the truth table of a NAND gate.

## PART II

*Answer **six** questions in this part, choosing **two** questions from **each** of the Sections **A**, **B** and **C**.*

### SECTION A

*(Answer any **two** questions)*

#### Question 2

- (a) Figure 5 (a) below shows a parallel plate air capacitor whose capacitance is  $2 \mu\text{F}$ . [4]

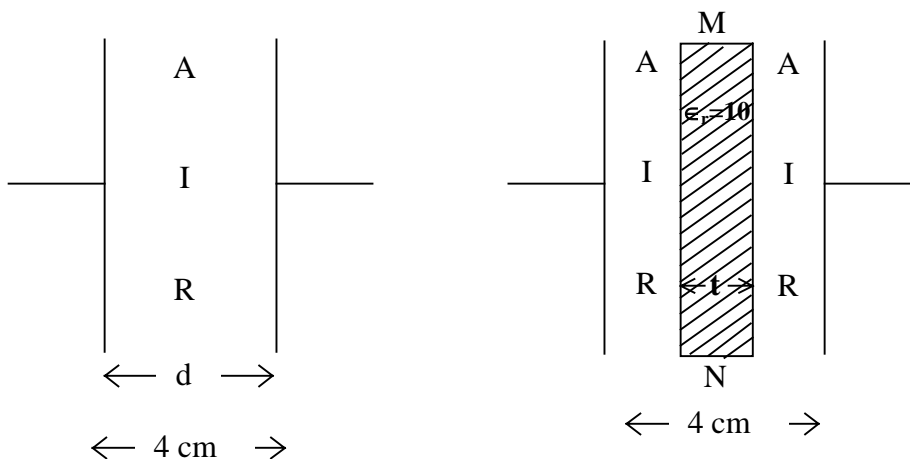

Figure 5 (a)

Figure 5 (b)

A dielectric slab MN of thickness  $t = 2 \text{ cm}$  and having dielectric constant (relative permittivity) = 10 is now introduced between the two plates (See figure 5 (b))

Find the new capacitance of the system.

- (b) Using Gauss' Theorem, calculate intensity of electric field at a point at a radial distance of 3 cm from an infinite line charge having linear charge density of  $5 \times 10^{-6} \text{ Cm}^{-1}$ . [2]  
(Statement of Gauss' Theorem or derivation not required).
- (c) What is meant by temperature coefficient of resistance? Write down Ohm's Law in vector form, stating the meaning of every symbol used. [3]

**Question 3**

- (a) Draw a labelled diagram of a balanced Wheat Stone bridge. Using either Ohm's Law or Kirchoffs' Laws, obtain the relation between four resistors forming the bridge. [3]
- (b) Figure 6 below shows a potentiometer circuit. When the jockey is pressed on the slide wire AB at a point C such that  $AC = 2.9\text{m}$ , the galvanometer 'G' shows no deflection. Find the emf of the cell X. [3]

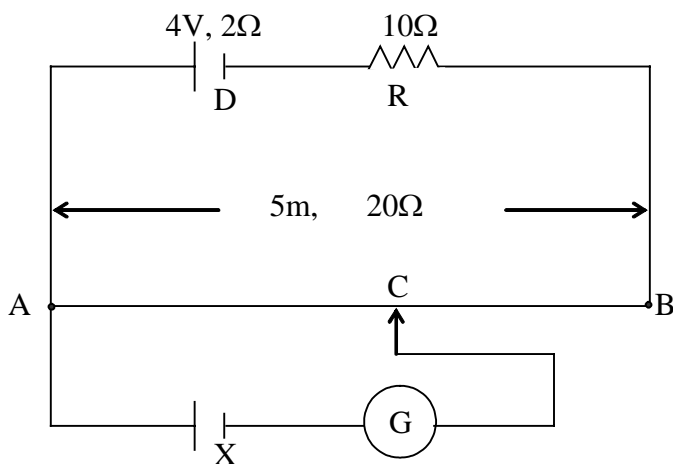

Figure 6

[Slide wire AB is 5m long and has a resistance of  $20\Omega$ .]

- (c) Figure 7 below shows three resistors:  $R_1 = 10\Omega$ ,  $R_2 = 20\Omega$  and  $R_3 = 90\Omega$ . When a current I enters the circuit, heating power developed in  $R_1$  is found to be 90 W. Calculate the heating power developed in  $R_3$ . [3]

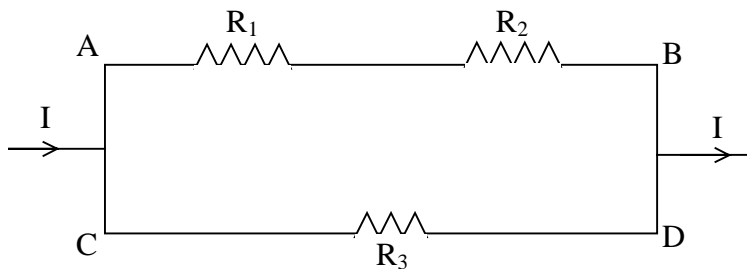

Figure 7

#### Question 4

- (a) Using Ampere's circuital law, obtain an expression for magnetic flux density 'B' at a point 'P' near an infinitely long straight conductor carrying a current 'I'. [3]
- (b) Show graphically how a d.c current flowing through an LR circuit varies with time when the key is put (i) on (ii) off. What is meant by time constant of an LR circuit? [3]
- (c) A  $(\frac{25}{\pi^2})\mu F$  capacitor 'C' and a  $50\ \Omega$  resistor 'R' are connected in series to a 220V, 50Hz a.c supply. It is desired to have a current of 2A in phase with supply voltage. Find the value/s of additional component/s to be connected in series with C and R. [3]

#### SECTION B

(Answer any two questions)

#### Question 5

- (a) Which electro-magnetic wave is longer than a light wave but shorter than a micro-wave? How can it be detected? Name only one detector. [2]
- (b) In Young's double slit experiment, what is the effect of the following changes on the interference pattern: [3]
- Distance between the two slits is decreased.
  - One of the slits is covered with a thin mica sheet.
  - Monochromatic light is replaced by white light.
- (c) Ordinary light i.e. unpolarized light is incident on a glass slab (refractive index = 1.6) at a polarizing angle  $\theta_p$  as shown in figure 8 below. [3]

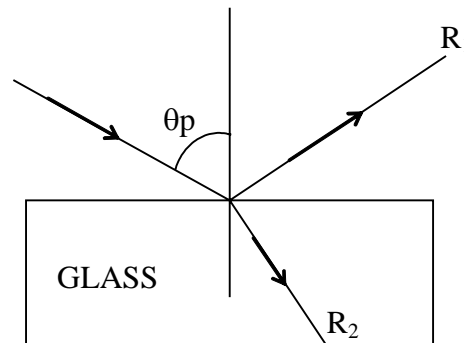

Figure 8

- Find the value of angle  $\theta_p$ .
- What is the angle between the reflected ray  $R_1$  and the refracted ray  $R_2$ ?
- What is the difference between the incident light and the reflected light, as far as their electric vectors are concerned?

### Question 6

- (a) An air bubble 'A' is trapped inside a glass sphere of radius  $CP = 10$  cm at a distance of 4.0 cm from its centre 'C'. Where does it appear to an observer O (See figure 9) who is looking at it along the diameter from the side to which it is nearest? [3]

(Refractive Index of glass = 1.5)

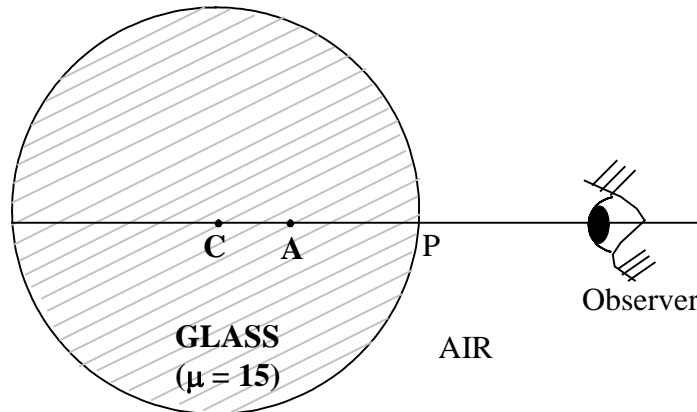

Figure 9

- (b) A beam of light converges to a point X. A convex lens of focal length 30 cm is now introduced in its path in order to intercept the rays, at a distance of 30 cm from X. The rays of light now meet at a point Y. Draw the ray diagram showing the position of X & Y and calculate the distance XY. [3]
- (c) What are Fraunhofer lines? Explain how they are formed. [2]

### Question 7

- (a) Explain the statement: "Angular magnification of an astronomical telescope in normal adjustment is 20". What is meant by resolving power of a telescope? [3]
- (b) Draw a labelled ray diagram of an image formed by a Compound Microscope in normal use. Write down an expression for its magnifying power in terms of focal lengths of the two lenses used. [3]
- (c) When a narrow and parallel beam of monochromatic light is incident normally on a rectangular slit of width  $1 \times 10^{-6}$  m, angular width of central maxima in the diffracted light was found to be  $60^\circ$ . Find the wave length of the incident light. [2]

## SECTION C

(Answer any **two** questions from the following)

### Question 8

- (a) In Millikan's oil drop experiment, charge  $q$  on an oil drop is given by [3]

$$q = \frac{K}{E} \sqrt{V_1} (V_1 - V_2).$$

- (i) What is the difference between  $V_1$  and  $V_2$ ?
- (ii) What is meant by the term: "Quantisation of charge"?
- (b) When UV radiation of wavelength 198.0 nm is incident on a Caesium photo cell, a negative potential difference of 4.2V has to be applied to just cut off the photo-current. Calculate threshold frequency for metal Caesium. [3]
- (c) (i) Find angular momentum of an electron in Bohr's III orbit. [2]
- (ii) What is the radius of III<sup>rd</sup> orbit of an electron in hydrogen atom?

### Question 9

- (a) Explain the terms: [2]
- (i) Mass defect.
- (ii) Binding energy of a nucleus.
- (b) (i) In Nuclear Physics, what is the use of a cyclotron ? [2]
- (ii) In a nuclear reactor, what is the function of a moderator ?
- (c) (i) State Mosley's Law. [4]
- (ii) What is a neutrino?
- (iii) Half life of a certain radio active element is 6 hours. If you start with 32g of this element, how much of it would disintegrate in one day?



### Question 10

- (a) Draw labelled energy band diagram for each of the following: [3]
- (i) A semi-conductor.
  - (ii) An insulator.
  - (iii) A good conductor.
- (b) Draw a labelled circuit diagram of a full wave rectifier using two junction diodes. You must show clearly where input voltage is applied and where output voltage is taken. [3]
- (c) Show how an OR gate can be obtained using NAND gates. [2]

### USEFUL CONSTANTS

- |    |                                                 |   |                            |   |                                  |
|----|-------------------------------------------------|---|----------------------------|---|----------------------------------|
| 1. | Speed of light in vacuum                        | : | $c$                        | = | $3 \times 10^8 \text{ ms}^{-1}$  |
| 2. | Planck's constant                               | : | $h$                        | = | $6.6 \times 10^{-34} \text{ Js}$ |
| 3. | Constant of proportionality for Coulomb's Law   | : | $\frac{1}{4\pi\epsilon_0}$ | = | $9 \times 10^9 \text{ mF}^{-1}$  |
| 4. | Bohr radius                                     | : | $a_0$                      | = | $5.3 \times 10^{-11} \text{ m}$  |
| 5. | Charge of a proton                              | : | $e$                        | = | $1.6 \times 10^{-19} \text{ C}$  |
| 6. | Constant of proportionality for Biot Savart Law | : | $\frac{\mu_0}{4\pi}$       | = | $10^{-7} \text{ Hm}^{-1}$        |