

Lines and Angles

Points, Line Segments, Lines, Rays, Planes and Space

Points, line segments, lines, and rays are the basic ideas on which the world of geometry is based. In order to understand geometry, we should be very clear about these basic ideas.

Let us start with the concept of a point. In order to understand the idea of a point, let us consider the sharp tip of a pencil or the pointed end of a pin.



Now, look at the line segments AB and CD.



Length of segment AB is 5 cm and that of segment CD is 3 cm.

Mathematically, their respective lengths can be written as follows:

$$l(AB) = 5 \text{ cm and } l(CD) = 3 \text{ cm}$$

We have seen what lines, rays, and line segments are, so let us now study another concept, which is the concept of planes.

A plane is a flat surface having length and width, but no thickness. We can say that a plane is a flat surface, which extends indefinitely in all directions.

For example, surface of a wall, floor of a ground, etc.

A plane can be denoted by writing small letters inside it such as letters p , q , etc.

For example:



This plane is read as “plane p ”.

Also, a plane can be denoted by taking 3 different points, say X, Y, Z in the plane, but not on same line.

For example:

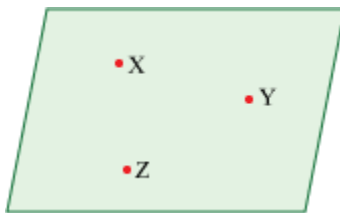

This plane is read as “plane XYZ”.

Do you think that there is any relation between points and lines in a plane?

The answer to this question is ‘yes’ and the relations between them are called incidence properties.

To understand the incidence properties, look at the following video.

Some axioms:

(1) There is exactly one plane passing through three non-collinear points.

Observe the given figure.

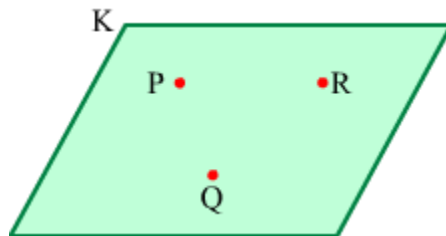

Here, points P, Q and R are three non-collinear points. K is the plane passing through these points.

(2) There is exactly one plane which passes through a line and a point not lying on the line.

Look at the following figure.

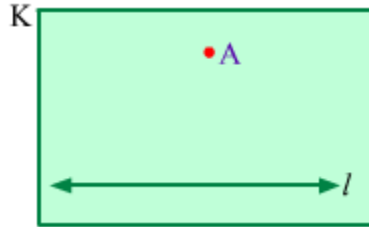

Here, plane K passes through the line l and the point A which does not lie on the line l .

(3) Only one plane can pass through two distinct intersecting lines.

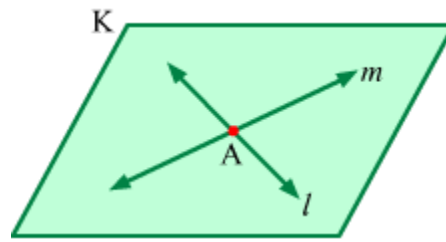

In the figure given above, lines l and m intersect each other at point A. Plane K passes through these lines.

(4) A line is obtained by intersection of two planes.

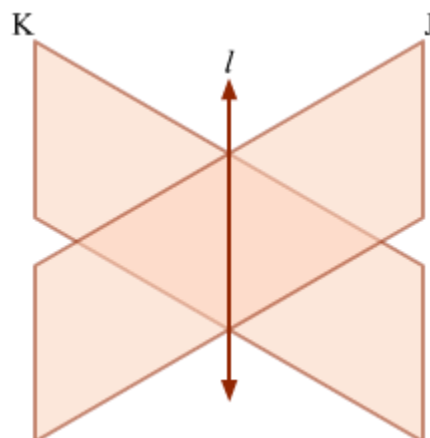

In the figure given above, planes J and K intersect each other. Line l is obtained by their intersection.

(5) When a plane is intersected by a line, which does not lie in the plane, then a point is obtained.

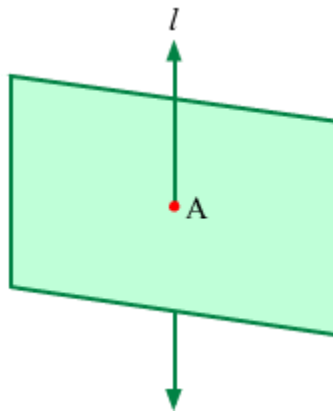

In the figure given above, line l does not lie in the plane K and it intersects the plane at point A .

Parallel planes:

Planes which do not intersect each other are said to be parallel.

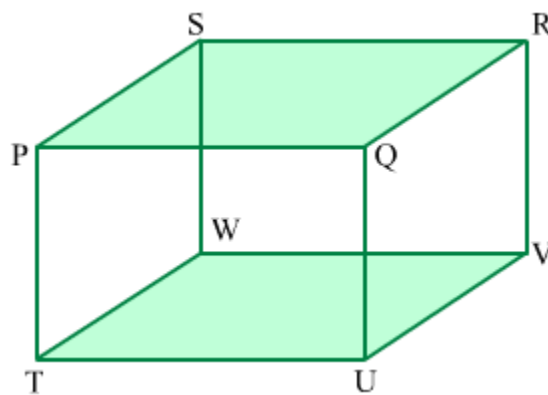

In the above given figure, planes $PQRS$ and $TUVW$ do not intersect each other and hence, these are parallel planes.

Similarly, $PTWS$ and $QUVR$ is a pair of parallel planes while $PTUQ$ and $SWVR$ is another pair of parallel planes.

Length of a line segment:

The length of a line segment is the distance between the end points of the line segment.

Length of a line segment PQ is denoted as $l(PQ)$ and distance between two points is denoted as $d(P, Q)$.

Therefore, $l(PQ) = d(P, Q)$.

Here after $l(PQ)$ is denoted as PQ and thus, $PQ = l(PQ) = d(P, Q)$.

Congruent segment:

If two line segments are of equal length, then they are said to be congruent.



In the above figure, $l(PQ) = l(RS)$. So, line segments PQ and RS are congruent.

Mathematically, if $l(PQ) = l(RS)$, then $\text{seg } PQ \cong \text{seg } RS$.

Note: While considering the length of segment PQ, we write only PQ but while considering the set of points between P and Q (segment as a whole), we write seg PQ or side PQ.

Mid-point of a segment:

If A is a point such that $P - A - Q$ and $d(P, A) = d(A, Q)$ then A is said to be the mid-point of the segment PQ.

Every line segment has one and only one mid-point.



In the above figure, $\text{seg } PA \cong \text{seg } AQ$.

Comparison of segments:

Observe the below given figure.

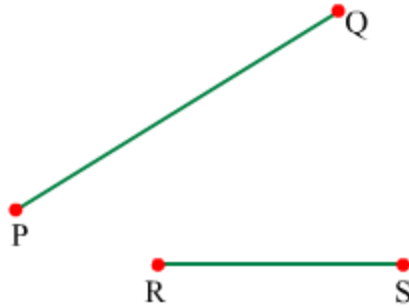

Here, $RS < PQ$ so, it can be said seg RS is smaller than seg PQ. This information is denoted as $seg RS < seg PQ$.

Opposite rays:

If two rays have same origin and are contained in the same line, then the rays are known as opposite rays.



In the above figure, ray RP and ray RQ are opposite rays.

Plane separation axiom:

In a plane, a given line and points which do not lie on the line form two disjoint sets say H_1 and H_2 .

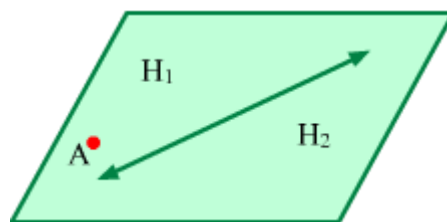

Each of the sets H_1 and H_2 is known as the half plane and the given line is called the edge of each half plane.

If A is any point in any of the half planes then that half plane is known as A side of the half plane.

Let us discuss some examples based on these basic geometrical ideas.

Example 1:

With respect to the given figure, name

- (a) any six line segments
- (b) a line
- (c) three rays
- (d) two pairs of intersecting lines

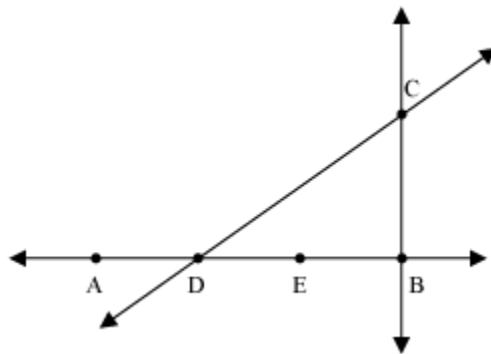

Solution:

- (a) Six line segments shown in the figure are \overline{AD} , \overline{AE} , \overline{DE} , \overline{DB} , \overline{BE} , and \overline{BC} .
- (b) \overline{AB} is a line in the given figure.
- (c) Three rays in the given figure are \overline{DA} , \overline{DB} , and \overline{DC} .
- (d) Two pairs of intersecting lines in the given figure are \overline{AB} and \overline{BC} , and \overline{DC} and \overline{BC} .

Example 2:

Draw rough figures of the following.

- (a) A line \overline{AB}
- (b) Points P and Q that lie on line \overline{AB}
- (c) A line \overline{XY} that intersects line \overline{AB} at point Q

(d) A line \overline{DE} that is parallel to line \overline{XY} and passes through point P

Solution:

(a)



(b)



(c)

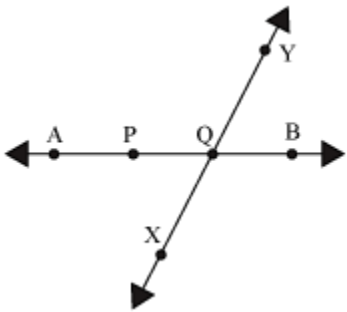

(d)

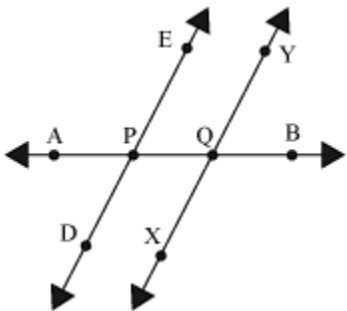

Example 3:

With respect to the given figure, state whether the following statements are correct or incorrect.

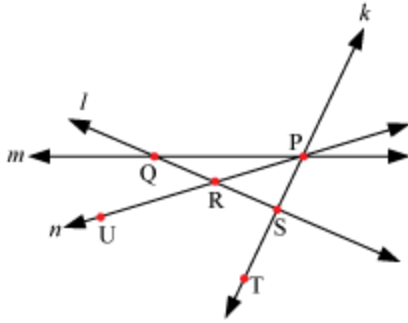

- (a) The points P, S, and T are collinear points.
- (b) The lines k , l , and n are concurrent lines.
- (c) The point U, R, and S are collinear points.
- (d) The point P is the point of concurrence of lines k , m , and n .

Solution:

- (a) Correct
- (b) Incorrect; since the lines k , l , and n do not pass through the same point
- (c) Incorrect; since the points U, R, and S do not lie on the same line
- (d) Correct

Example 4:

Write the lengths of given line segments.



Solution:

It can be seen that the length of segment PQ is 10 cm and that of segment RS is 8 cm.

Mathematically, their respective lengths can be written as follows:

$$l(PQ) = 10 \text{ cm and } l(RS) = 8 \text{ cm}$$

Classification of Angles

Let us consider a situation. Suppose that you are facing North. You turn around making a complete revolution such that you again face North. The angle you turned by is a **complete angle**. Try the same for different directions and you will obtain the same results.

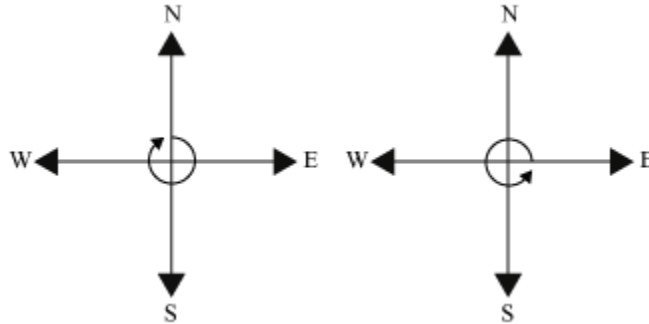

Now, suppose while facing the North direction, if you turn around making a half turn, then the angle you turned by is a **straight angle**, and if you turn around making a quarter turn, then the angle you turned by is a **right angle**.

Now, consider a notebook and look at the angle made by the adjacent sides.

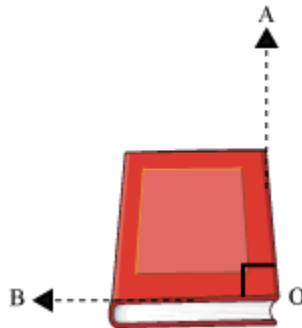

The adjacent sides OB and OA of the notebook form an angle AOB. This angle is a **right angle**.

Similarly, the sides of the alphabet 'L' form a right angle.

Now, consider the hour and minute hands of a clock when the time is 8'o clock as shown in the figure below.



What angle is formed between the hands of the clock?

It is clear from the above discussions that the angle shown in the figure is not among right angle, straight angle, and complete angle. Therefore, how can we classify this angle?

Let us first look at different types of angles.

1. An angle smaller than a right angle is called an **acute angle** i.e., acute angle $< 90^\circ$.
2. An angle larger than a right angle but smaller than a straight angle is called an **obtuse angle** i.e., $90^\circ < \text{Obtuse angle} < 180^\circ$.
3. An angle larger than a straight angle but smaller than a complete angle is called a **reflex angle** i.e., $180^\circ < \text{Reflex angle} < 360^\circ$.

The following figures are examples of the different types of angles.

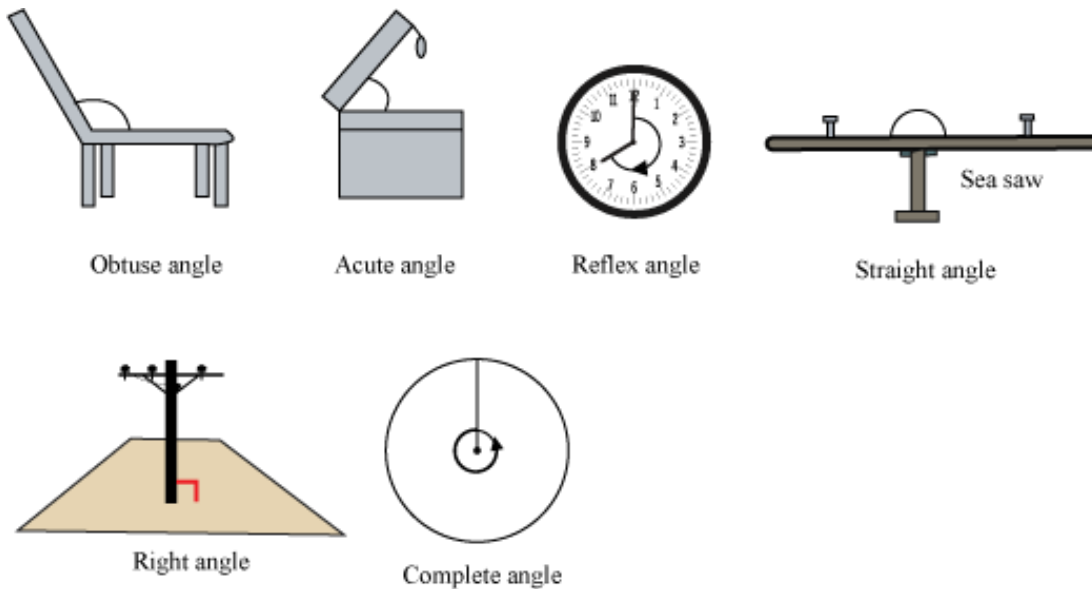

We cannot always say which angle is the greatest out of the given two angles merely by looking at the angles. To compare the angles, we have to measure the angles individually.

An angle is measured in terms of degrees. One complete revolution is equivalent to 360° ($^\circ$ is the symbol of degrees). Thus, the measure of a complete angle is 360° .

The measure of a straight angle is 180° and the measure of a right angle is 90° .

Now, observe the ray OP.



If this ray does not rotate from this position, then the directed angle so formed by the ray is known as the **zero angle**. In other words, it can be said that the amount of rotation of the ray OP about the point O is 0.

The measure of zero angle is 0° .

Let us now look at some examples to understand this concept better.

Example 1:

Does the hour hand of a clock make a straight angle when it moves from

1. **12 noon to 6 pm**
2. **5 pm to 10 pm**
3. **2 am to 8 am**
4. **3 pm to 9 pm**
5. **11 am to 7 pm**
6. **3 am to 6 am**

Solution:

We know that two straight angles make a complete angle. A complete angle means a complete revolution. Thus, to make a complete angle, the hour hand has to cross 12 hour marks. To make a straight angle, the hour hand of a clock has to cross 6 hour marks.

1. When the hour hand of a clock moves from 12 noon to 6 pm, it covers 6 hour marks and thus forms a straight angle.
2. When the hour hand of a clock moves from 5 pm to 10 pm, it covers 5 hour marks. Thus, the angle formed is less than a straight angle.
3. When the hour hand of a clock moves from 2 am to 8 am, it covers 6 hour marks and thus forms a straight angle.
4. When the hour hand of the clock moves from 3 pm to 9 pm, it covers 6 hour marks and thus forms a straight angle.
5. When the hour hand of the clock moves from 11 am to 7 pm, it covers 8 hour marks. Thus, the angle formed is more than a straight angle.
6. When the hour hand of the clock moves from 3 am to 6 am, it covers 3 hour marks. Thus, the angle formed measures less than a straight angle.

Example 2:

Does the hour hand of a clock make a complete angle when it goes from

1. 3 am to 3 pm
2. 9 am to 8 pm
3. 5 pm to 6 am
4. 7 pm to 7 am

Solution:

We know that a complete angle means a complete revolution. Thus, the hour hand will make a complete angle when it moves from a mark and comes back to the same mark again. By looking at the above four cases, we observe that the hour hand of a clock forms a complete angle in the following cases.

i) 3 am to 3 pm

iv) 7 pm to 7 am

Example 3:

Classify each of the following angles as acute, right, obtuse, straight, or reflex.

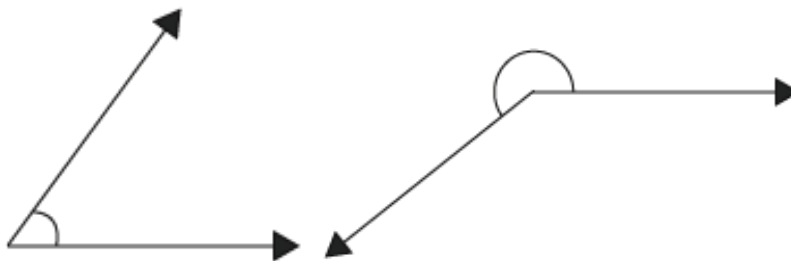

(i)

(ii)

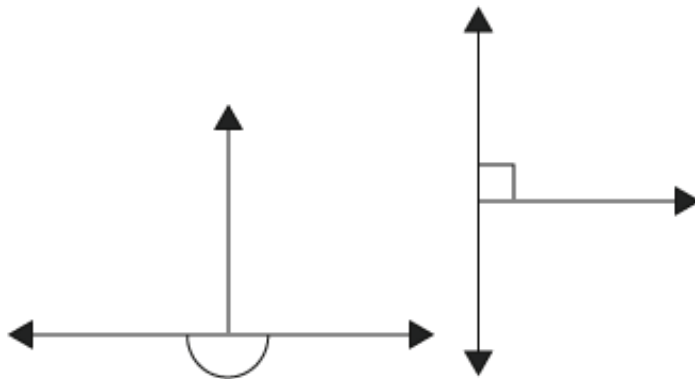

(iii)

(iv)



(v)

Solution:

1. The given angle is smaller than a right angle. Hence, it is an acute angle.
2. The given angle is more than a straight angle and less than a complete angle. Hence, it is a reflex angle.
3. The given angle is formed on a straight line and is thus a straight angle.
4. The given angle is a right angle.
5. The given angle is more than a right angle and less than a straight angle. Hence, it is an obtuse angle.

Example 4:

The measures of some angles are given below. Classify these angles based on their measures.

1. 280° (iii) 90° (v) 56°
2. 180° (iv) 360° (vi) 108°

Solution:

1. The measure of a reflex angle lies between 180° (straight angle) and 360° (complete angle). Since the given measure is 280° , the angle is a reflex angle.
2. The measure of a straight angle is 180° . Since the given measure is also 180° , the angle is a straight angle.
3. The measure of a right angle is 90° . Since the given measure is also 90° , the angle is a right angle.
4. The measure of a complete angle is 360° . Since the given measure is also 360° , the angle is a complete angle.
5. The measure of an acute angle is less than 90° (right angle). Since the given measure is 56° , the angle is an acute angle.
6. The measure of an obtuse angle lies between 90° (right angle) and 180° (straight angle). Since the given measure is 108° , the angle is an obtuse angle.

Example 5:

Where will the hour hand of a clock stop, if it starts from

1. **6 and turns through two right angles**
2. **5 and turns through two straight angles**
3. **4 and turns through one right angle**

Solution:

1. Since the hour hand turns through two right angles, it crosses 6 hour marks. Therefore, the hour hand will stop at 12.
2. Since the hour hand turns through two straight angles, it makes a complete revolution. Therefore, the hour hand will stop at 5.
3. Since the hour hand turns through one right angle, it crosses 3 hour marks. Therefore, the hour hand will stop at 7.

Example 6:

Find in degrees the angle between the hands of a clock at 4'o clock.

Solution

At 4'o clock, we notice that there are two angles formed by the hands of a clock.



In 4 hours, the hour hand of a clock rotates $\frac{4}{12}$ turn. Hence, the smaller angle between the hands at 4'o clock is $\frac{4}{12}$ turn.

We know that,

$$1 \text{ turn} = 360^\circ$$

$$\therefore \frac{4}{12} \text{ turn} = \frac{4}{12} \times 360^\circ = \frac{1}{3} \times 360^\circ = 120^\circ$$

Now, since the larger and the smaller angle add up to 1 complete turn, the larger angle

between the hands at 4'o clock is $\left(1 - \frac{4}{12}\right)$ turn $= \frac{8}{12}$ turn

$$\frac{8}{12} \text{ turn} = \frac{8}{12} \times 360^\circ = \frac{2}{3} \times 360^\circ = 240^\circ$$

Linear Pair of Angles

A ray OZ stands on a line XY such that $\angle ZOY = 72^\circ$, as shown in the following figure.

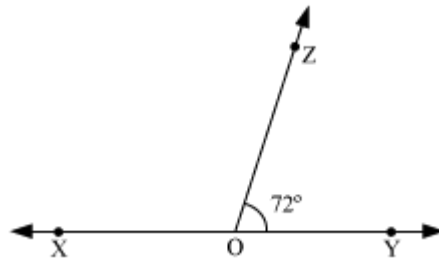

Can we find $\angle XOZ$?

We can find $\angle XOZ$ using the concept of linear pair.

Therefore, first of all let us know about the linear pair of angles.

“A linear pair is a pair of adjacent angles and whose non-common sides are opposite rays.”

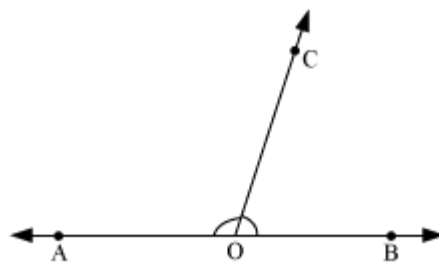

In the above figure, $\angle AOC$ and $\angle BOC$ form a linear pair. Their non-common arms form a straight line.

In other words, we can say, **“When a ray stands on a line, the two angles thus obtained form a linear pair”**.

One very important property of a linear pair of angles is that **the sum of measures of linear pair of angles is equal to 180°** .

Now, let us solve the above given example using this property.

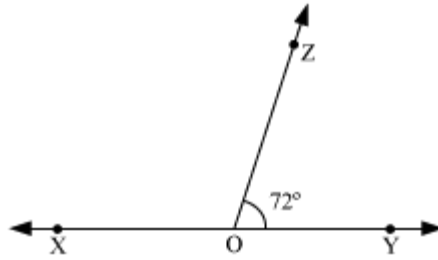

Here, we have to find $\angle XOZ$.

Now, $\angle XOZ$ and $\angle ZOY$ form a linear pair. Therefore,

$$m\angle XOZ + m\angle ZOY = 180^\circ$$

$$m\angle XOZ + 72^\circ = 180^\circ$$

$$m\angle XOZ = 180^\circ - 72^\circ$$

$$m\angle XOZ = 108^\circ$$

We can also state this property as **“The sum of angles lying on a straight line is equal to 180° ”**.

Now consider the following figure:

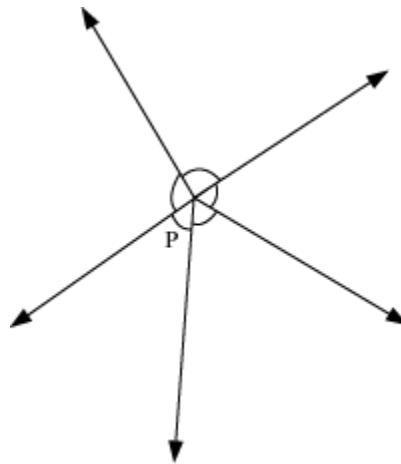

In this figure, five angles have a common vertex, which is point P. In other words, the five angles make a complete turn and therefore the sum of these five angles will be equal to 360° . This is true no matter how many angles make a complete turn.

“The sum of angles around a point is equal to 360° ”.

Let us solve some examples to understand the above discussed concept better.

Example 1:

Which of the following pairs of angles forms a linear pair?

(i)

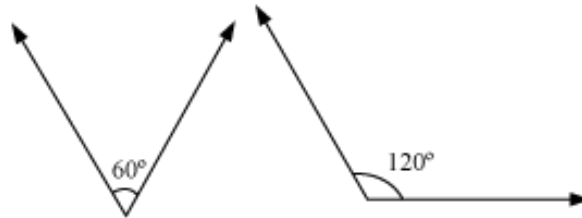

(ii)

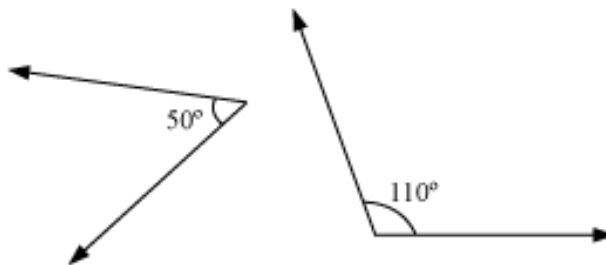

Solution:

(i) Sum of measures of angles = $60^\circ + 120^\circ$

$$= 180^\circ$$

Thus, the given pair forms a linear pair of angles.

(ii) Sum of the measures of angles = $50^\circ + 110^\circ$

$$= 160^\circ$$

Thus, the given pair does not form a linear pair of angles.

Example 2:

Can two acute angles form a linear pair of angles?

Solution:

Two acute angles cannot be supplementary angles as the sum of the measures of two acute angles is less than 180° . Therefore, two acute angles cannot form linear pair of angles.

Example 3:

In the given figure, $\angle POQ = \angle SOT$. Find the measure of $\angle QOR$.

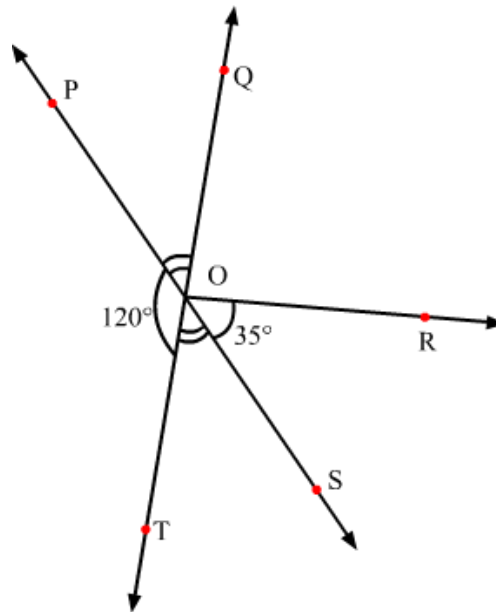

Solution:

In the given figure, $\angle POT$ and $\angle SOT$ form a linear pair.

Therefore,

$$\angle POT + \angle SOT = 180^\circ$$

$$\Rightarrow \angle SOT = 180^\circ - 120^\circ = 60^\circ$$

Now, it is given that $\angle SOT = \angle POQ$

$$\therefore \angle POQ = 60^\circ$$

Now, we know that the sum of angles around a point is equal to 360° . Therefore,

$$\angle POT + \angle SOT + \angle SOR + \angle QOR + \angle POQ = 360^\circ$$

$$\Rightarrow 120^\circ + 60^\circ + 35^\circ + \angle QOR + 60^\circ = 360^\circ$$

$$\Rightarrow \angle QOR = 360^\circ - 275^\circ$$

$$\Rightarrow \angle QOR = 85^\circ$$

Example 4:

Let \overline{OA} , \overline{OB} and \overline{OC} be three rays such that \overline{OC} is between \overline{OA} and \overline{OB} . If $\angle BOC + \angle COA = 180^\circ$, then prove that A, O, B are collinear, that is, they lie on the same straight line.

Solution:

Given: \overline{OA} , \overline{OB} and \overline{OC} are three rays. $\angle BOC$ and $\angle COA$ are adjacent angles formed by the rays such that $\angle BOC + \angle COA = 180^\circ$.

To Prove: A, O, B all lie on the same line.

Construction:

Extend \overline{AO} to D such that A, O, D all lie on the same line AD.

Proof:

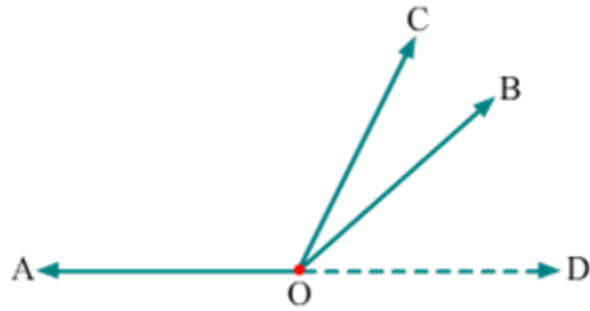

Fig (1)

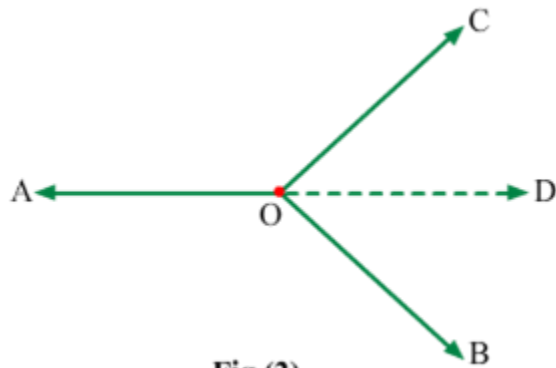

Fig (2)

Since AD is a line,
 $\therefore \angle DOC + \angle COA = 180^\circ \dots(1)$

Given, $\angle BOC + \angle COA = 180^\circ \dots(2)$

From (1) and (2), we have
 $\angle DOC + \angle COA = \angle BOC + \angle COA$

$$\Rightarrow \angle DOC = \angle BOC$$

Now, there are two possibilities:

1. \overline{OB} lies between \overline{OD} and \overline{OC} (fig 1)
2. \overline{OD} lies between \overline{OB} and \overline{OC} (fig 2)

From the first possibility, we have
 $\angle BOC = \angle DOC = \angle DOB + \angle DOC \Rightarrow \angle DOB = 0$

From the second possibility, we have
 $\angle DOC = \angle BOC = \angle BOD + \angle DOC \Rightarrow \angle BOD = 0$

Thus, the angle between the rays \overline{OB} and \overline{OD} is zero. Hence, the rays \overline{OB} and \overline{OD} coincide. This means that the points B and O are on the same line AD. Thus, A, O, B are collinear.

Example 5:

Let AB be a straight line and \overline{OC} be any ray standing on it. If \overline{OP} is the bisector of $\angle BOC$ and \overline{OQ} is the bisector of $\angle COA$, then prove that $\angle POQ = 90^\circ$.

Solution:

Given: \overline{OP} is the bisector of $\angle BOC$ and \overline{OQ} is the bisector of $\angle COA$.

To prove: $\angle POQ = 90^\circ$

Proof:

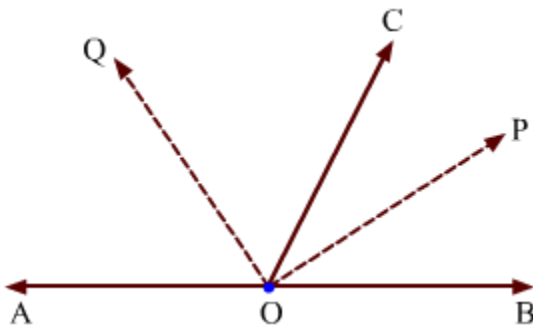

Since \overline{OP} is the bisector of $\angle BOC$, we have

$$\angle POC = \frac{1}{2} \angle BOC \quad \dots(1)$$

Since \overline{OQ} is the bisector of $\angle COA$, we have

$$\angle COQ = \frac{1}{2} \angle COA \quad \dots(2)$$

Adding (1) and (2), we have

$$\angle POQ = \frac{1}{2} (\angle BOC + \angle COA)$$

$$\Rightarrow \angle POQ = \frac{1}{2} \times 180^\circ = 90^\circ$$

Adjacent Angles

Look at the following figures. You will see that some angles are marked in the figures as 1, 2, 3, and 4.

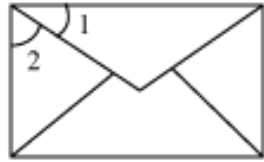

What did you notice?

In the figure of the envelope, $\angle 1$ and $\angle 2$ are adjacent angles. Similarly, in the figure of the chair, $\angle 3$ and $\angle 4$ are adjacent angles.

To understand the conditions in which two angles are adjacent, look at the following video.

Some more adjacent angles are shown below.

(i)

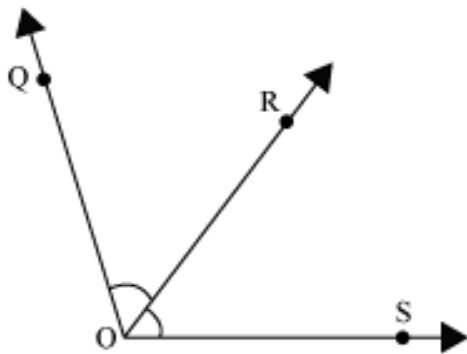

$\angle QOR$ and $\angle ROS$

(ii)

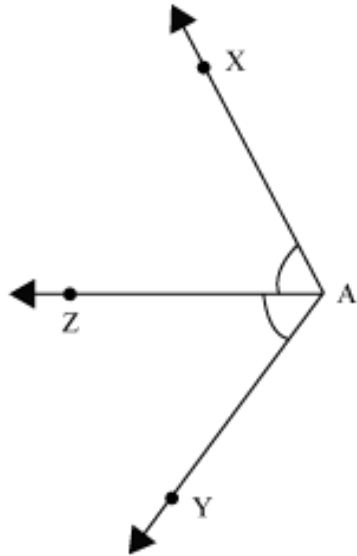

$\angle XAZ$ and $\angle ZAY$

Now, let us discuss some examples based on the above concept.

Example 1:

Find out the pairs of adjacent angles from the following pairs of angles.

(i)

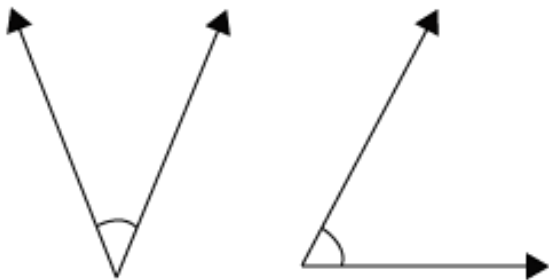

(ii)

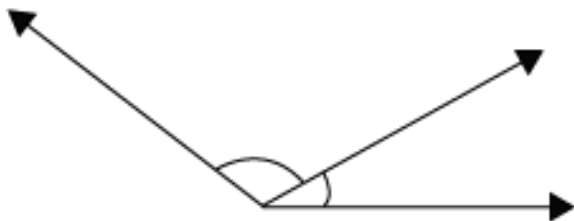

(iii)

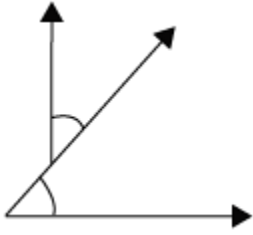

(iv)

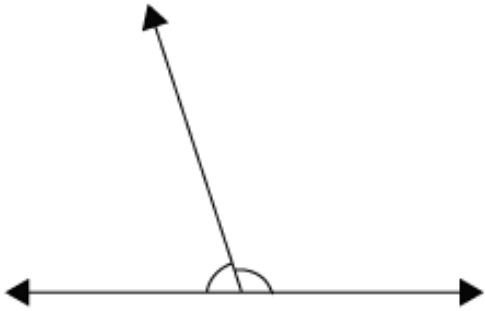

(v)

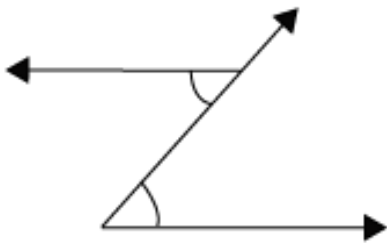

(vi)

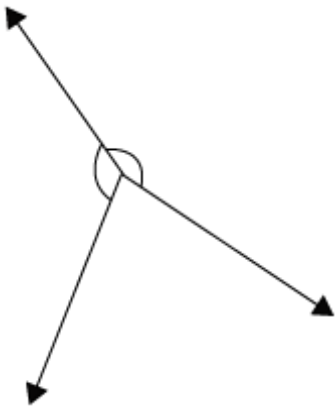

Solution:

The pairs of angles in figures (ii), (iv), and (vi) are adjacent angles. These angles share a common vertex and a common side but no common internal points.

In figure (i), the two angles are totally different.

In figures (iii) and (v), the given angles do not share a common vertex.

Hence, the pairs of angles in figures (i), (iii), and (v) are not adjacent angles.

Example 2:

Find out whether the following statements are correct or incorrect.

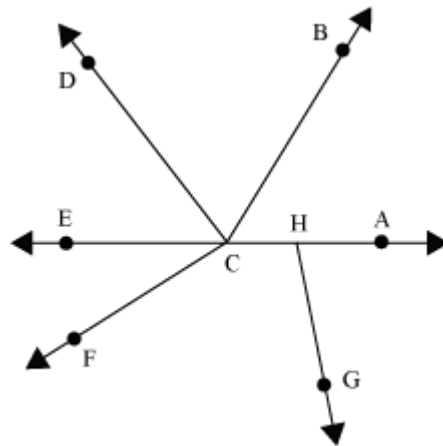

1. $\angle ACB$ is adjacent to $\angle DCE$.
2. $\angle ECF$ is adjacent to $\angle BCE$.
3. $\angle BCF$ is not adjacent to $\angle BCA$.
4. $\angle GHA$ is adjacent to $\angle DCF$.

Solution:

1. False. The angles do not share a common side.
2. True. The angles share a common vertex and a common side but no common internal points.
3. False. $\angle BCF$ is adjacent to $\angle BCA$.

4. False. The angles share neither a common side nor a common vertex.

Example 3:

The sum and the difference of two adjacent angles is 99° and 5° respectively. Find the measures of the two angles.

Solution:

Let the measure of one angle be x .

Since the sum of the measures of the angles is 99° , the measure of the other angle will be $99^\circ - x$.

Now, we know that the difference between the angles is 5° .

$$\therefore x - (99^\circ - x) = 5^\circ$$

$$\Rightarrow x - 99^\circ + x = 5^\circ$$

$$\Rightarrow 2x - 99^\circ = 5^\circ$$

By adding 99° to both sides, we get

$$2x - 99^\circ + 99^\circ = 5^\circ + 99^\circ$$

$$\Rightarrow 2x = 104^\circ$$

$$\text{i.e., } x = \frac{104}{2}$$

Hence, $x = 52^\circ$

Hence, the measure of one angle is 52° and the measure of other angle is $99^\circ - 52^\circ = 47^\circ$.

Complementary and Supplementary Angles

So, the two important definitions of complementary and supplementary angles are as follows.

“If the sum of the measures of two angles is 90° , then the two angles are said to be complement to each other or complementary angles”.

“If the sum of the measures of two angles is 180° , then the two angles are said to be supplement to each other or supplementary angles.”

Let us solve some examples related to complementary and supplementary angles to understand the concept better.

Example 1:

Find the complement of the following angles.

52° and 75°

Solution:

$$\text{Complement of } 52^\circ = 90^\circ - 52^\circ$$

$$= 38^\circ$$

$$\text{Complement of } 75^\circ = 90^\circ - 75^\circ$$

$$= 15^\circ$$

Example 2:

Find the supplement of the following angles.

100° and 36°

Solution:

$$\text{Supplement of } 100^\circ = 180^\circ - 100^\circ$$

$$= 80^\circ$$

$$\text{Supplement of } 36^\circ = 180^\circ - 36^\circ$$

$$= 144^\circ$$

Example 3:

Can two acute angles be supplementary angles?

Solution:

No, two acute angles cannot be supplementary angles. The measure of an acute angle is less than 90° . Therefore, the sum of the measures of two acute angles is always less than 180° .

Example 4:

Write True or False.

(i) The opposite angles of a square are complementary angles.

(ii) Two obtuse angles can be supplementary angles.

Solution:

(i) False, as each angle of a square is a right angle.

$$\text{Sum of two opposite angles} = 90^\circ + 90^\circ$$

$$= 180^\circ$$

(ii) False, because the measure of an obtuse angle is greater than 90° . Therefore, the sum of the measures of two obtuse angles cannot be 180° .

Example 5:

An angle measures four times its supplementary angle. Find the measures of both the angles.

Solution:

Let the measure of the supplementary angle of the given angle be x° then the measure of the given angle will be $4x^\circ$.

According to the definition of supplementary angles, we obtain

$$4x^\circ + x^\circ = 180^\circ$$

$$\Rightarrow 5x^\circ = 180^\circ$$

$$\Rightarrow x^\circ = 36^\circ$$

$$\therefore 4x^\circ = 4 \times 36^\circ$$

$$\Rightarrow 4x^\circ = 144^\circ$$

Thus, the measures of the given angles are 144° and 36° .

Example 6:

The measure of an angle is 6° more than the twice of its complementary angle.
Find the measures of both the angles.

Solution:

Let the measure of the complementary angle of the given angle be x° then the measure of the given angle will be $2x^\circ + 6^\circ$.

According to the definition of complementary angles, we obtain

$$2x^\circ + 6^\circ + x^\circ = 90^\circ$$

$$\Rightarrow 3x^\circ + 6^\circ = 90^\circ$$

$$\Rightarrow 3x^\circ = 84^\circ$$

$$\Rightarrow x^\circ = 28^\circ$$

$$\therefore 2x^\circ + 6^\circ = 2 \times 28^\circ + 6^\circ$$

$$\Rightarrow 2x^\circ + 6^\circ = 56^\circ + 6^\circ$$

$$\Rightarrow 2x^\circ + 6^\circ = 62^\circ$$

Thus, the measures of the given angles are 62° and 28° .

Vertically Opposite Angles

Let us consider the following figure.

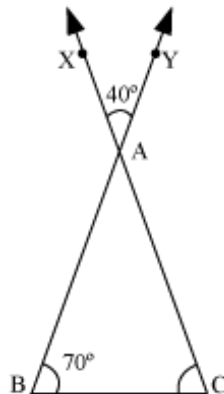

Can you find the measure of $\angle ACB$?

In the given figure, one angle of $\triangle ABC$ is given as 70° and the other two angles are unknown. We know that the sum of all the three angles of a triangle is 180° . We can find $\angle ACB$, if we can find $\angle BAC$.

Therefore, first of all, we have to find $\angle BAC$. We can easily do so by using the concept of vertically opposite angles.

Given: Two lines XC and YB intersecting each other at a point A.

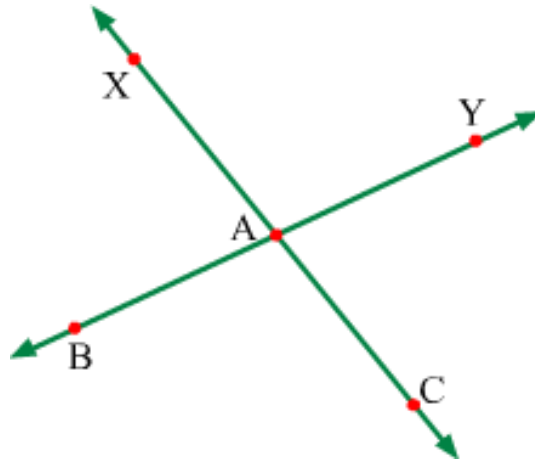

To prove: $\angle XAY = \angle BAC$ and $\angle XAB = \angle CAY$

Proof: Since lines XC and YB intersect each other, we have

$$\angle XAB + \angle CAB = 180^\circ \quad \dots(1) \quad (\text{Linear pair})$$

$$\text{Also, } \angle CAB + \angle CAY = 180^\circ \quad \dots(2) \quad (\text{Linear pair})$$

From (1) and (2), we have

$$\Rightarrow \angle XAB + \angle CAB = \angle CAB + \angle CAY$$

$$\Rightarrow \angle XAB = \angle CAY$$

Similarly, we can easily prove that $\angle XAY = \angle BAC$.

Therefore, if two lines intersect each other then vertically opposite angle are equal.

Let us solve some more examples to understand the concept better.

Example 1:

In the given figure, if $\angle 1 = 75^\circ$, then find $\angle 2$, $\angle 3$, and $\angle 4$.

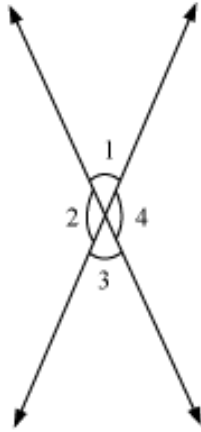

Solution:

$\angle 1$ and $\angle 4$ form a linear pair of angles.

$$\therefore \angle 1 + \angle 4 = 180^\circ$$

$$\Rightarrow 75^\circ + \angle 4 = 180^\circ$$

$$\Rightarrow \angle 4 = 180^\circ - 75^\circ$$

$$\Rightarrow \angle 4 = 105^\circ$$

Now, $\angle 1$ and $\angle 3$ are vertically opposite angles,

$$\therefore \angle 1 = \angle 3 = 75^\circ$$

Again, $\angle 2$ and $\angle 4$ are vertically opposite angles,

$$\therefore \angle 2 = \angle 4 = 105^\circ$$

Example 2:

In the given figure, name the pairs of vertically opposite angles.

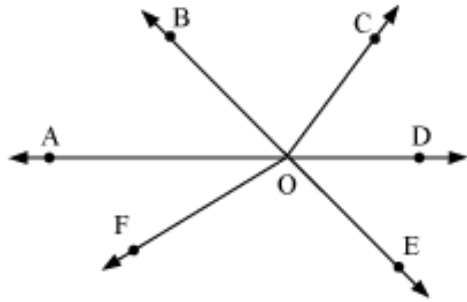

Solution:

There are two pairs of vertically opposite angles in the given figure.

(1) $\angle AOB$ and $\angle DOE$

(2) $\angle BOD$ and $\angle AOE$

Transversal on Two Lines

Suppose there are two parallel roads in a city and a third road is cutting the two roads as shown in the figure below:

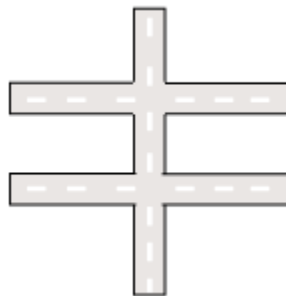

We can see that the third road is intersecting the two roads at two distinct points. We call this as a **transversal** to the other two roads.

The line which intersects two or more lines at distinct points is called transversal to the lines.

Also, the part of the transversal which lie between the lines is known as intercept.

For example, consider the following figures.

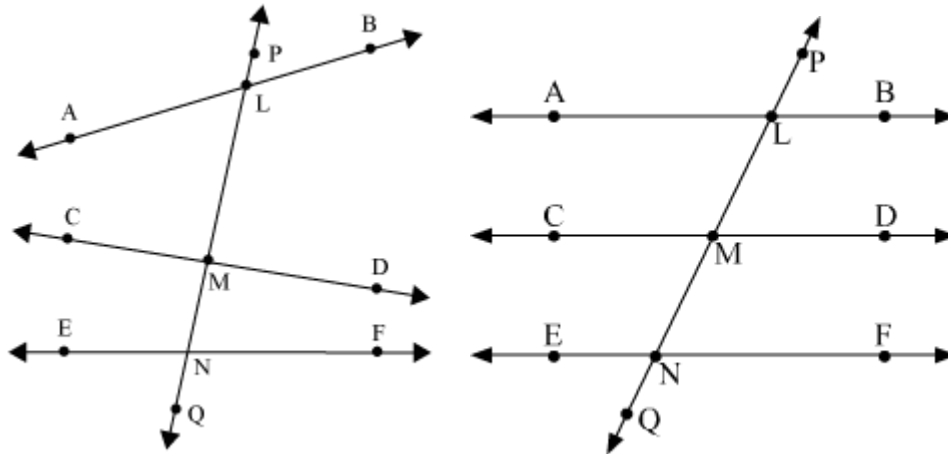

In the above figures, we can see that a line \overline{PQ} intersects the lines \overline{AB} , \overline{CD} , and \overline{EF} (in second figure, $\overline{AB} \parallel \overline{CD} \parallel \overline{EF}$) at three distinct points L, M, and N respectively.

Therefore, \overline{PQ} is a transversal to the lines \overline{AB} , \overline{CD} and \overline{EF} .

Also, LM is the intercept of the transversal \overline{PQ} between \overline{AB} and \overline{CD} . Similarly, MN is the intercept of the transversal \overline{PQ} between \overline{CD} and \overline{EF} .

Now, let us discuss about the **angles made by a transversal** with the lines, with which it intersects.

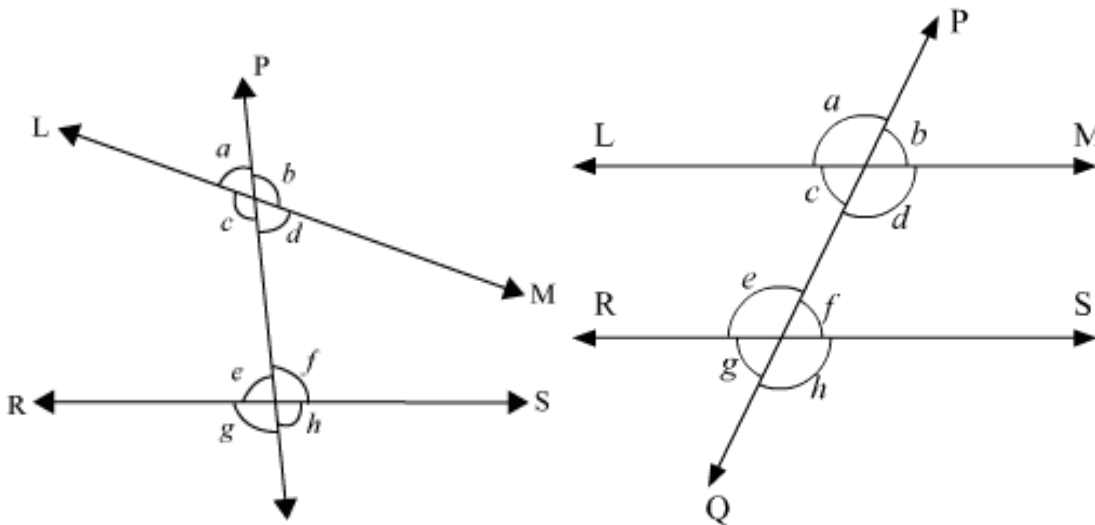

In the above figures, we can see that the line \overleftrightarrow{PQ} intersects two lines \overleftrightarrow{LM} and \overleftrightarrow{RS} (in second figure, $\overleftrightarrow{LM} \parallel \overleftrightarrow{RS}$) at two distinct points. Therefore, \overleftrightarrow{PQ} is a transversal to the lines \overleftrightarrow{LM} and \overleftrightarrow{RS} .

Construction of Copy of Angles Using Ruler and Compass

If we draw two rays from the same starting point as shown in the figure, then what figure will we obtain?

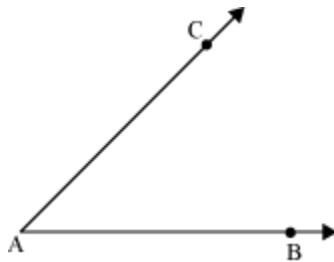

Yes, you are right. It is an angle.

Can you draw the copy of a given angle?

Yes, you can do so. You will first measure the angle using protractor and then draw an angle of the same measure.

What will you do if you do not have a protractor? Can you copy an angle using only ruler and compasses?

In this way, we can copy the given angles using ruler and compasses.

Construction of Bisector of Angles Using Ruler and Compass

Let us begin with the definition of the bisector of an angle.

“The ray that divides an angle into two equal parts is called the bisector of that angle”.

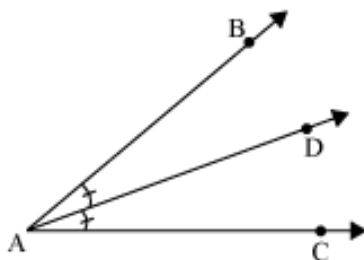

In the given figure, \overline{AD} will be the bisector of $\angle BAC$, if AD divides $\angle BAC$ into two equal parts i.e., $\angle BAD = \angle CAD$.

Now, let us know the method of construction of bisector of an angle using ruler and compasses.

Construction of Angles of Special Measures and Its Verification

Constructing Angles of Special Measures

You can easily draw different angles using a **protractor**. Another way of constructing angles involves the use of a ruler and a compass. Angles that are multiples of 15° (e.g., 30° , 45° , 60° , 90° , 120° , 135° , etc.) can be constructed in this way.

For example, we can construct an angle measuring 45° by bisecting an angle measuring 90° . Similarly, we can construct an angle measuring 120° with the help of an angle measuring 60° . In this lesson, we will learn how to construct such angles with the help of a ruler and a compass.

Constructing Angle of 30°

i) Construct an angle measuring 60° using a ruler and a compass, as is shown in the figure.

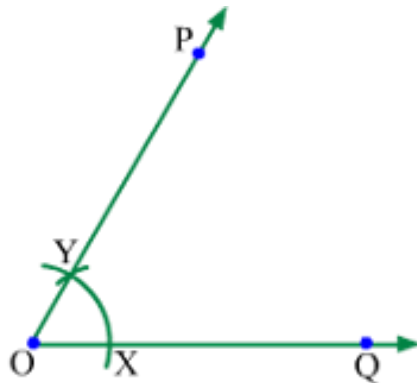

ii) Construct the bisector of $\angle POQ$ in the following manner. Draw two intersecting arcs taking X and Y as the centres and the radius as more than half of XY .

Let the arcs intersect at point R . Join O and R . Extend OR to form a ray OZ . OZ is the bisector of $\angle POQ$.

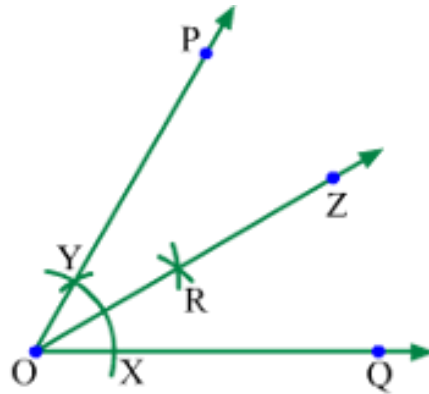

$$\therefore \angle POZ = \angle ZOQ = \frac{1}{2} \angle POQ = \frac{1}{2} \times 60^\circ = 30^\circ$$

Constructing Angle of 45°

i) Construct an angle measuring 90° using a ruler and a compass, as is shown in the figure.

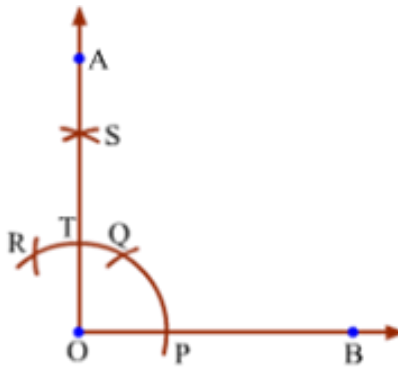

ii) Construct the bisector of $\angle AOB$ in the following manner. Draw two intersecting arcs taking T and P as the centres and the radius as more than half of TP. Let the arcs intersect at point X. Join O and X. Extend OX to form a ray OE. OE is the bisector of $\angle AOB$.

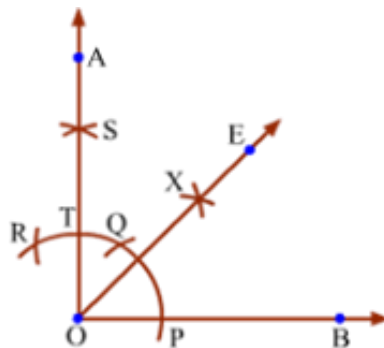

$$\therefore \angle AOE = \angle EOB = \frac{1}{2} \angle AOB = \frac{1}{2} \times 90^\circ = 45^\circ$$

Constructing Angle of 180°

i) Draw a line AB.



ii) Take a point O on AB, in between points A and B.

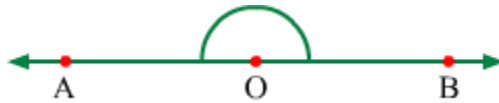

$\angle AOB$ is the required angle of measure 180° .

Solved Examples

Medium

Example 1:

Construct an angle measuring 135° .

Solution:

We know that $135^\circ = 45^\circ + 90^\circ$. So, we will first construct an angle measuring 90° and then an angle measuring 45° .

i) Draw a line AB and take a point O on it.

ii) Taking O as the centre and with a suitable radius, draw an arc such that it cuts AB at points C and F.

iii) Next, taking C as the centre and keeping the same radius as before, draw an arc intersecting the previous arc, say at point D. Now, with D as the centre and the same radius, draw an arc intersecting the first drawn arc, say at point E.

iv) Then, draw intersecting arcs taking D and E as the centres and the radius as more than of DE. Let the arcs intersect at point G. Join O and G. Extend OG to form a ray OH. Let OH intersect the first drawn arc at point I.

We will have $\angle HOA = \angle HOB = 90^\circ$.

v) Construct the bisector of $\angle HOA$ in the following manner. Draw intersecting arcs taking I and F as the centres and the radius as more than half of IF. Let the arcs intersect at point J. Join O and J. Extend OJ to form a ray OK. OK is the bisector of $\angle HOA$.

$$\therefore \angle HOK = \angle KOA = \frac{1}{2} \angle HOA = \frac{1}{2} \times 90^\circ = 45^\circ$$

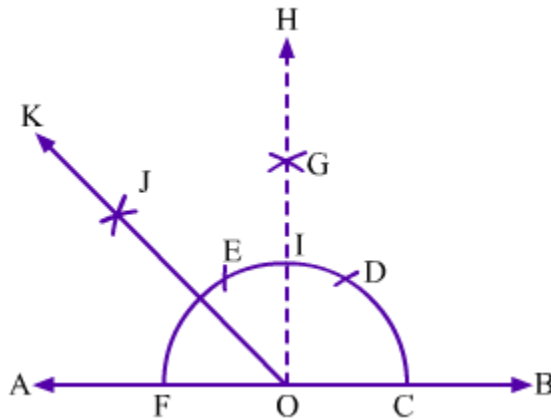

Now, $\angle KOB = \angle HOK + \angle HOB = 90^\circ + 45^\circ = 135^\circ$

Thus, $\angle KOB$ is the required angle of measure 135° .

Hard

Example 1:

Construct an angle measuring 22.5° .

Solution:

We know that $22.5^\circ = \frac{1}{2} \times 45^\circ$ and $45^\circ = \frac{1}{2} \times 90^\circ$. So, we will first construct an angle measuring 90° ; then, we will bisect it to get an angle measuring 45° ; and, finally, we will bisect the 45° angle to get an angle measuring 22.5° .

i) Draw a ray OB with the initial point O.

ii) Draw an arc taking O as the centre and with any radius, such that it cuts OB at point P.

iii) Taking P as the centre and with the same radius as before, draw an arc intersecting the previous arc, say at point Q. Now, with Q as the centre and the same radius, draw an arc intersecting the first drawn arc, say at point R.

iv) Then, draw intersecting arcs taking Q and R as the centres and the radius as more than half of QR. Let the arcs intersect at point S. Join O and S. Extend OS to form a ray OA. Let OA intersect the first drawn arc at point T.

We will have $\angle AOB = 90^\circ$.

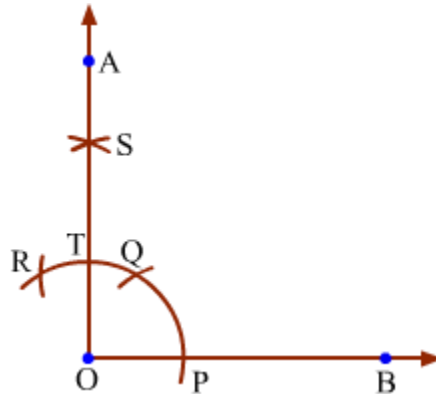

i) Construct the bisector of $\angle AOB$ in the following manner. Draw intersecting arcs taking T and P as the centres and the radius as more than half of TP. Let the arcs intersect at point X. Join O and X. Extend OX to form a ray OE. Let OE intersect the first drawn arc at point M. OE is the bisector of $\angle AOB$.

$$\therefore \angle AOE = \angle EOB = \frac{1}{2} \angle AOB = \frac{1}{2} \times 90^\circ = 45^\circ$$

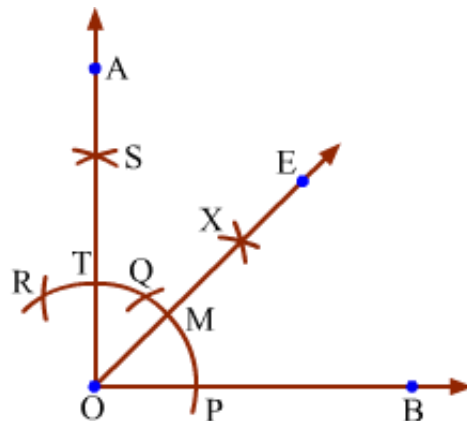

ii) Construct the bisector of $\angle EOB$ in the following manner. Draw intersecting arcs taking M and P as the centres and the radius as more than half of MP. Let the arcs

intersect at point Y. Join O and Y. Extend OY to form a ray OD. OD is the bisector of $\angle EOB$.

$$\therefore \angle EOD = \angle DOB = \frac{1}{2} \angle EOB = \frac{1}{2} \times 45^\circ = 22.5^\circ$$

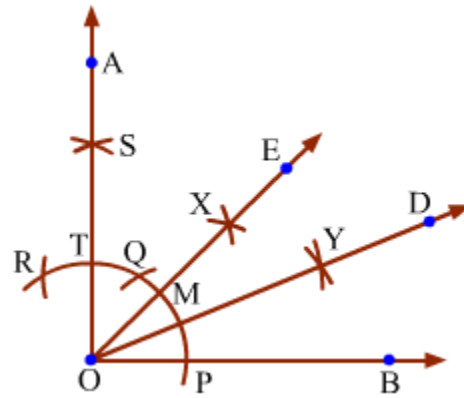

Construction of Perpendiculars to Lines

As shown in the following figures, the line passing through the adjacent edges of a book and the top surface and legs of a table are the examples of perpendicular lines.

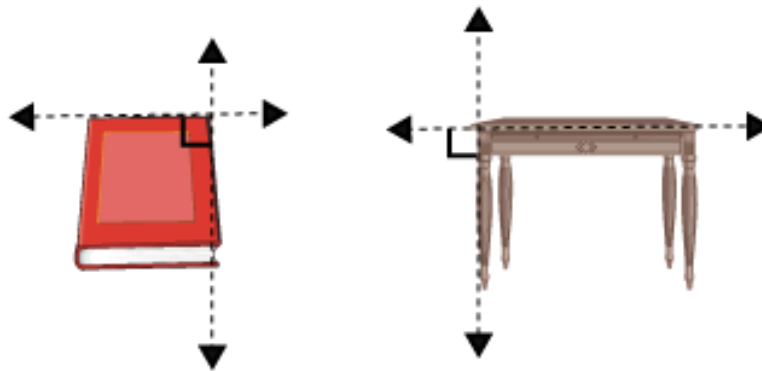

Perpendicular lines are two intersecting lines such that the angles formed by them are right angles.

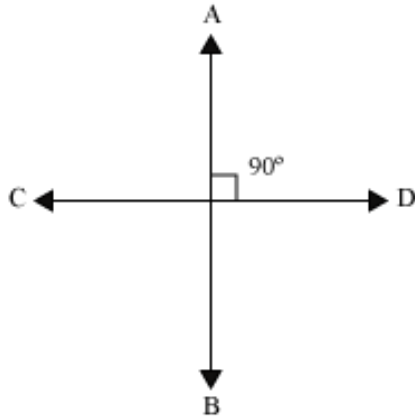

Now, we will learn to construct a perpendicular line to a given line. We can draw a perpendicular line to a given line at any point of the given line or from a point outside the given line.

Firstly, we will learn to draw the perpendicular line at any point of the given line. We can draw the perpendicular line by two methods:

1. Using ruler and compasses
2. Using ruler and set-square

Using ruler and set-square:

We can also draw a perpendicular line by using ruler and set-square. Therefore, first let us see what a set-square is.

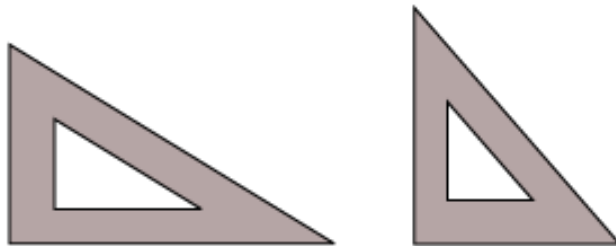

The set-squares are two right triangular instruments. One of the instruments contains angles 60° , 90° , and 30° while the other contains angles 45° , 90° , and 45° .

The set-squares are used to draw perpendicular and parallel lines.

Now, let us know the method to draw perpendicular line using ruler and set-square.

Now, we have learnt to draw a perpendicular to a line through a point on it. However, can we draw a perpendicular to a line through a point which is not on the line?

Let us try to draw.

Using ruler and compasses:

First, we will construct a perpendicular to a line through a point not on it with the help of ruler and compasses.

Using ruler and set-square:

Construction of Perpendicular Bisectors of Line Segments Using Ruler and Compass

If a line perpendicular to another line segment divides it into two equal parts, then it is called perpendicular bisector of the line segment.

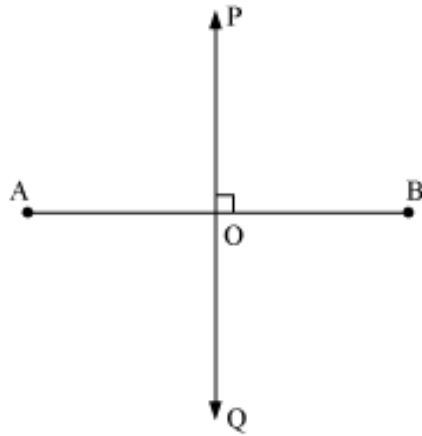

In this figure, AB is a line segment and the line PQ divides it into two equal parts and also, $\overline{PQ} \perp \overline{AB}$. Thus, we can say that PQ is the perpendicular bisector of \overline{AB} .

Now, let us learn how to construct the perpendicular bisector of a line segment using ruler and compasses.

In this way, we can draw a perpendicular bisector of a given line segment.

Construction of Parallel Lines

Look at the following figures.

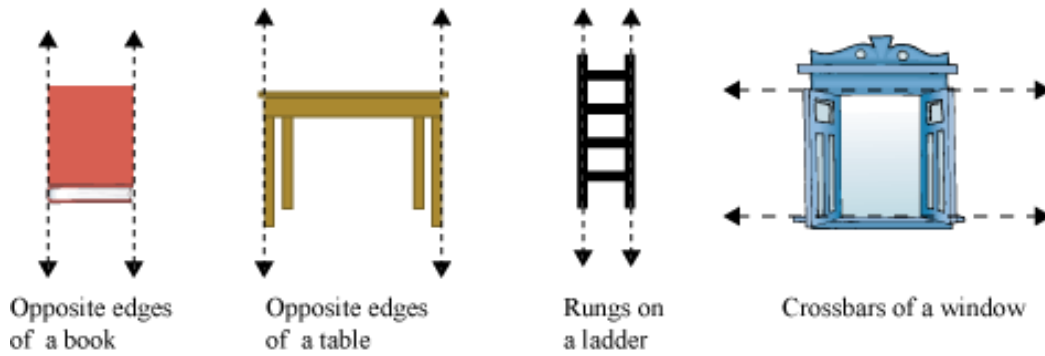

What do you notice? Is there something common in the given figures?

We can see that some lines have been shown in these figures such as the opposite edges of a book, the opposite edges of a table, the rungs on a ladder, the crossbars of a window, etc.

What is special about these lines?

These lines are parallel to each other and are called parallel lines.

When are two lines called parallel lines?

Parallel lines can be defined as follows:

“Two lines are called parallel lines if they do not intersect anywhere and they are at the same distance from each other along their entire length”.

In the given figure, \overline{AB} and \overline{CD} are parallel lines.



The steps involved in the construction of a line parallel to \overline{AB} through point P (using a ruler and a set square) are as follows:

1. Place your set square such that one of its shorter edges i.e., XY lies just along line AB.

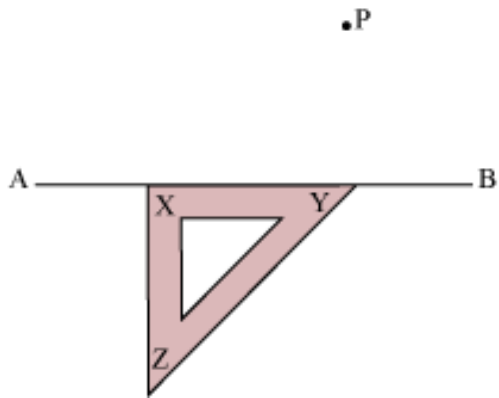

2. Place your ruler such that one of its edges lies just along the shorter edge i.e., XZ of the set square. Hold the ruler firmly and slide the set square along the ruler until the edge XY of the set square passes through P.

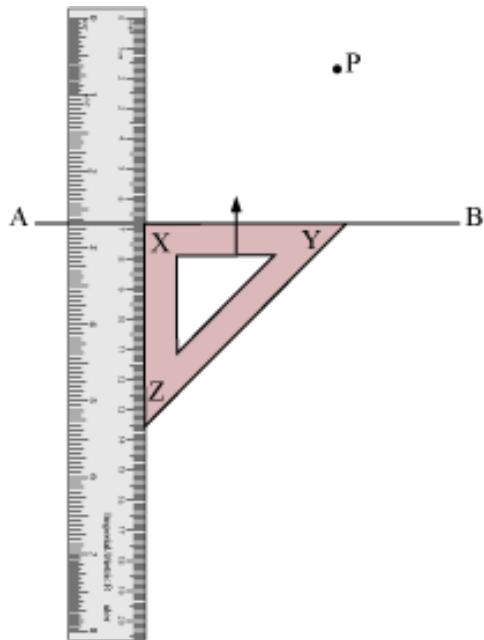

3. Draw a line along the edge XY of the set square. This is the required line through point P. Note that it is parallel to line AB.

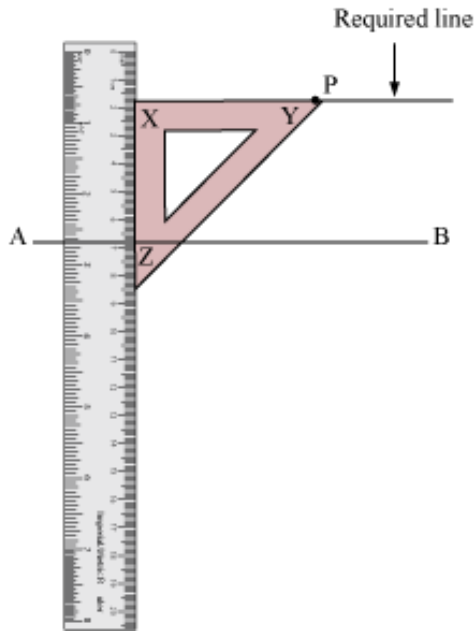

Let us now see another example to understand the concept of construction of parallel lines better.

Example 1:

Draw a line perpendicular to a given line \overline{AB} . Then draw a line parallel to \overline{AB} through any point on that perpendicular line using only ruler and compass.

Solution:

First of all, draw a line \overline{AB} . Now, we are required to draw a perpendicular to \overline{AB} .



Let us take a point C on \overline{AB} . Then, taking C as the centre, we draw an arc using the compass that cuts \overline{AB} at the points D and E respectively.

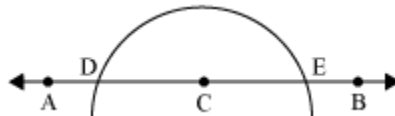

Now, with a radius greater than \overline{CD} , we draw two arcs with D and E as centres that intersect each other at point F. Then, we draw a line through the points C and F, which cuts the arc DE at point G. \overline{CF} is a line perpendicular to \overline{AB} .

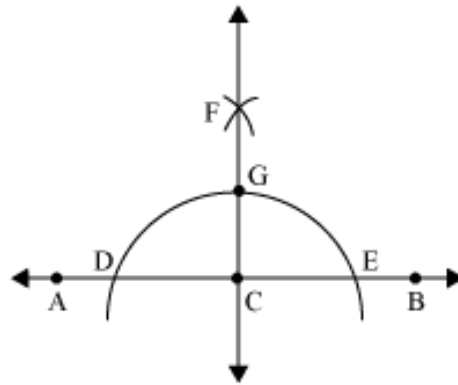

Taking the same radius and with F as centre, we draw an arc \widehat{PQ} , which cuts \overline{CF} at a point R.

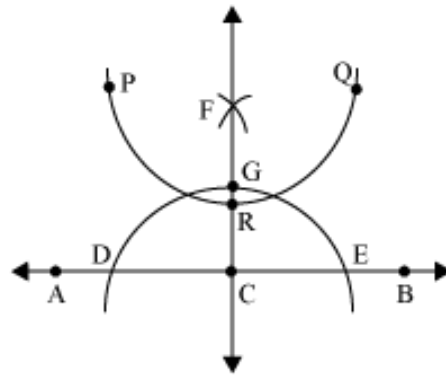

Now, let us measure the distance DG or EG with the help of compass. Then, taking that distance as the radius with R as the centre, we draw an arc that cuts the arc \widehat{PQ} at a point S.

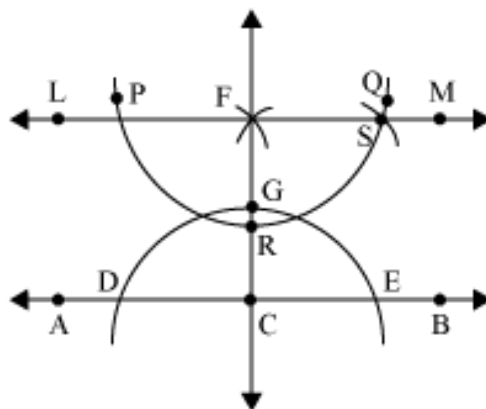

Now, we draw a line \overline{LM} through the points F and S using a ruler. The line \overline{LM} is perpendicular to \overline{FC} through a point F.

Thus, \overline{LM} is the required line, which is parallel to \overline{AB} and passing through a point on a line, which is perpendicular to \overline{AB} .