

# Visualising Solid Shapes

## CHAPTER 10







0852CH10

### 10.1 Introduction



In Class VII, you have learnt about plane shapes and solid shapes. Plane shapes have two measurements like length and breadth and therefore they are called two-dimensional shapes whereas a solid object has three measurements like length, breadth, height or depth. Hence, they are called three-dimensional shapes. Also, a solid object occupies some space. Two-dimensional and three-dimensional figures can also be briefly named as 2-D and 3-D figures. You may recall that triangle, rectangle, circle etc., are 2-D figures while cubes, cylinders, cones, spheres etc. are three-dimensional figures.

#### DO THIS

Match the following: (First one is done for you)

Shape	Type of Shape	Name of the shape
	3-dimensional	Sphere
	2-Dimensional	Cylinder
	3-dimensional	Square
	2-dimensional	Circle

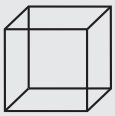
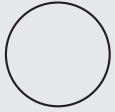

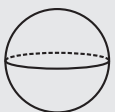
	3-dimensional	Cuboid
	3-dimensional	Cube
	2-dimensional	Cone
	3-dimensional	Triangle

Note that all the above shapes are single. However, in our practical life, many a times, we come across combinations of different shapes. For example, look at the following objects.



A tent  
A cone surmounted on a cylinder



A tin  
A cylindrical shell



Softy (ice-cream)  
A cone surmounted by a hemisphere

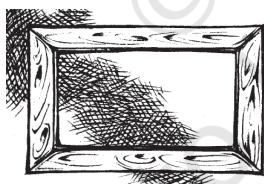

A photoframe  
A rectangular path



A bowl  
A hemispherical shell



Tomb on a pillar  
Cylinder surmounted by a hemisphere

### DO THIS

Match the following pictures (objects) with their shapes:

#### Picture (object)

- (i) An agricultural field



#### Shape

Two rectangular cross paths inside a rectangular park.

(ii) A groove		A circular path around a circular ground.	
(iii) A toy		A triangular field adjoining a square field.	
(iv) A circular park		A cone taken out of a cylinder.	
(v) A cross path		A hemisphere surmounted on a cone.	

## 10.2 Views of 3D-Shapes

You have learnt that a 3-dimensional object can look differently from different positions so they can be drawn from different perspectives. For example, a given hut can have the following views.

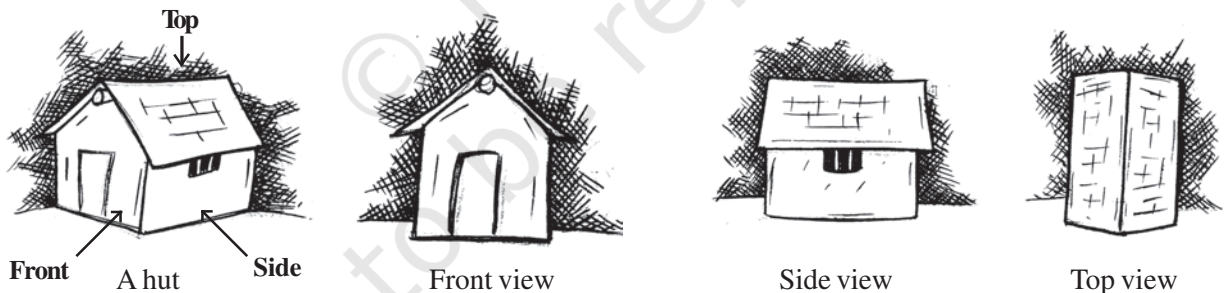

similarly, a glass can have the following views.



Why is the top view of the glass a pair of concentric circles? Will the side view appear different if taken from some other direction? Think about this! Now look at the different views of a brick.

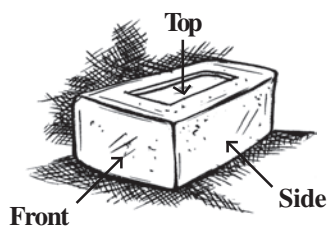

A brick



Front view



Side view

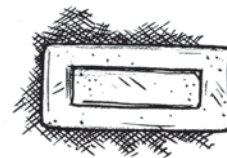

Top view

We can also get different views of figures made by joining cubes. For example.

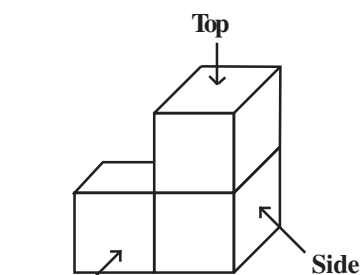

Solid made of three cubes



Side view

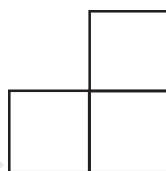

Front view



Top view

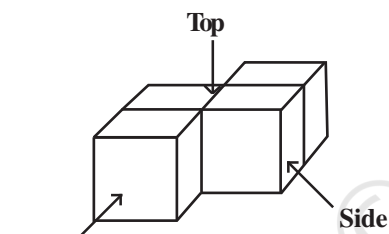

Solid made of four cubes

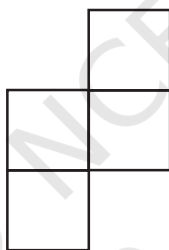

Top view



Front view



Side view

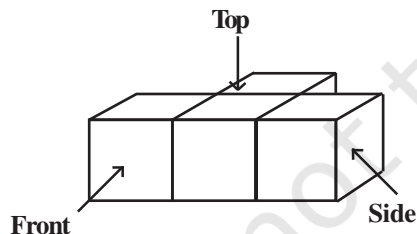

Solid made of four cubes



Side view

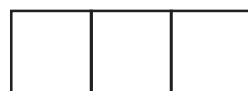

Front view

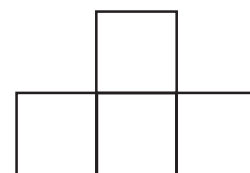















Top view

**DO THIS**

Observe different things around you from different positions. Discuss with your friends their various views.

## EXERCISE 10.1

1. For each of the given solid, the two views are given. Match for each solid the corresponding top and front views. The first one is done for you.

	Object	Side view	Top view
(a)	 A bottle	(i) 	(i) 
(b)	 A weight	(ii) 	(ii) 
(c)	 A flask	(iii) 	(iii) 
(d)	 Cup and Saucer	(iv) 	(iv) 
(e)	 Container	(v) 	(v) 

2. For each of the given solid, the three views are given. Identify for each solid the corresponding top, front and side views.

(a) **Object** (i) (ii) (iii)

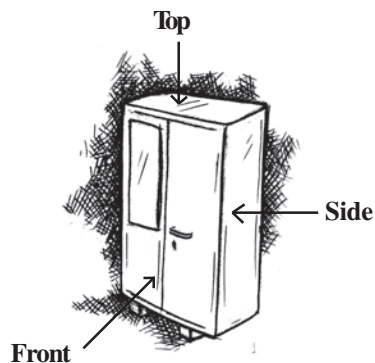

An almirah

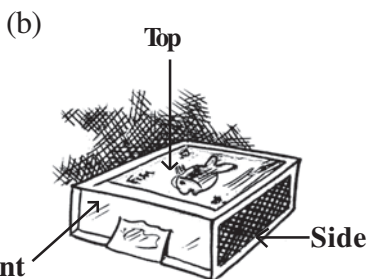

A Match box

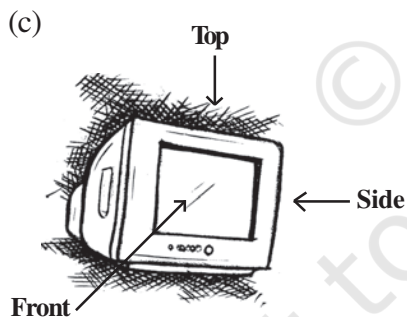
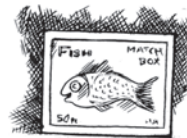

A Television

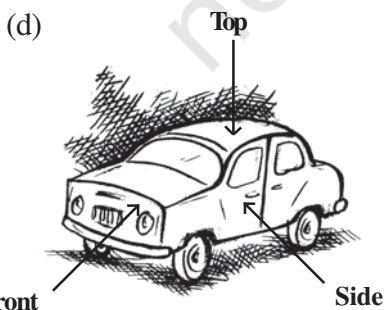

A car

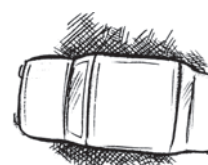

3. For each given solid, identify the top view, front view and side view.

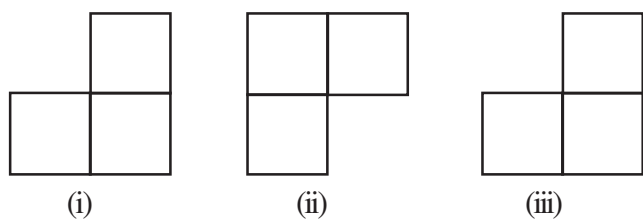
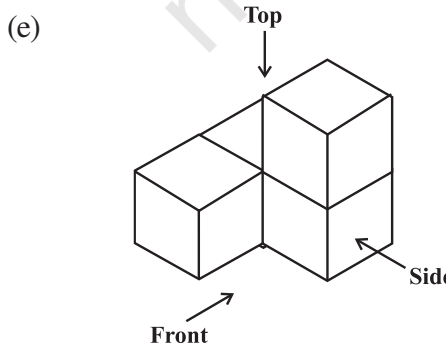
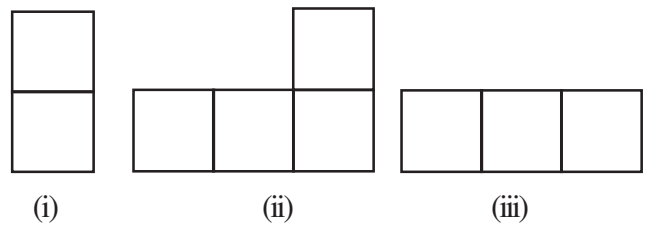
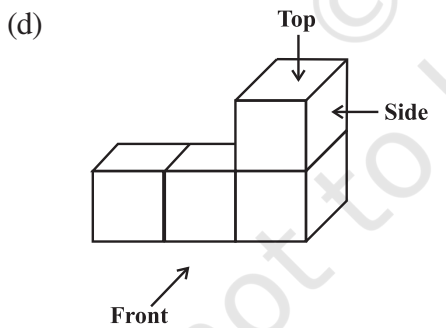
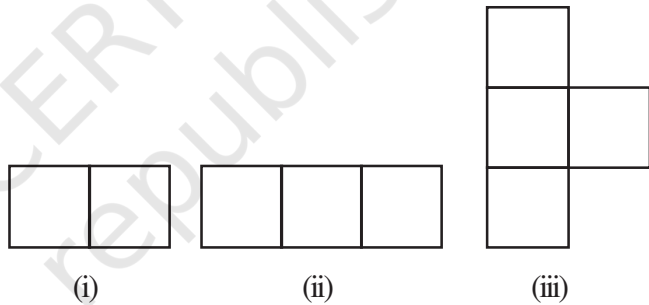
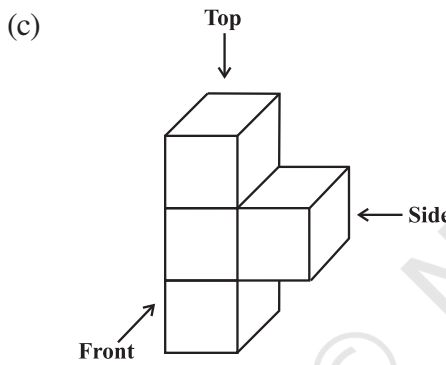
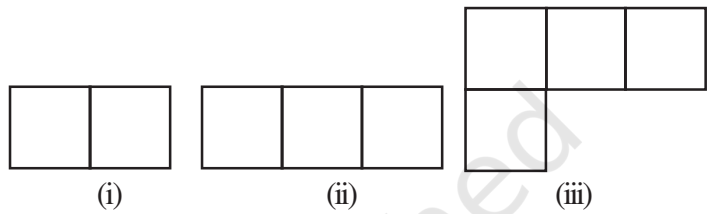
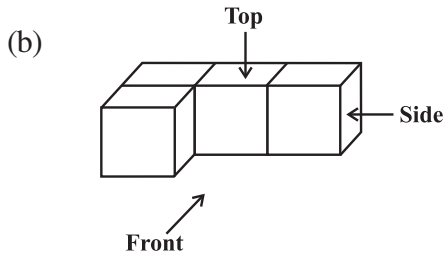
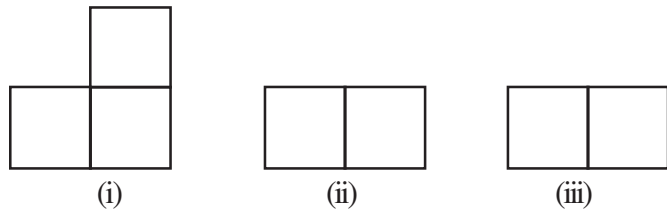
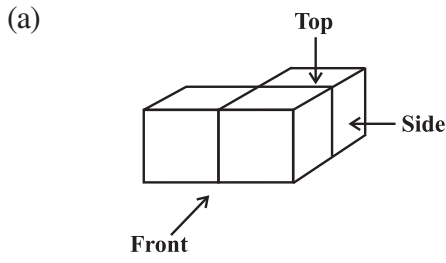

4. Draw the front view, side view and top view of the given objects.

(a) A military tent

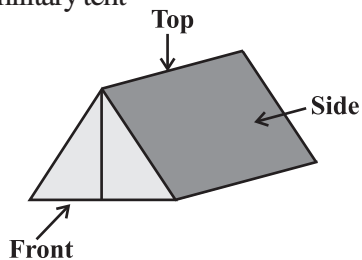

(b) A table

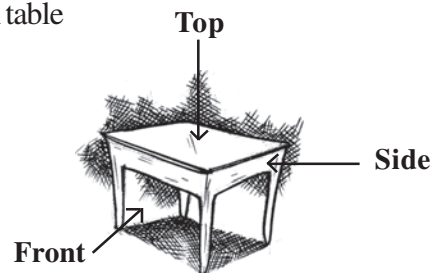

(c) A nut

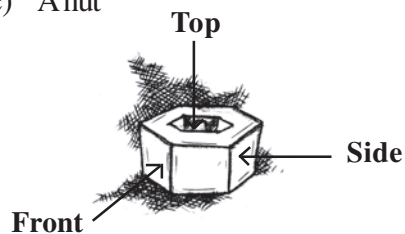

(d) A hexagonal block

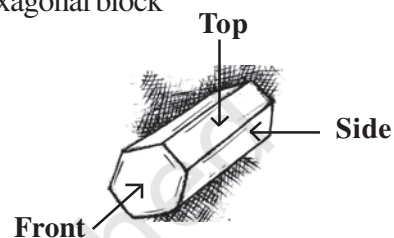

(e) A dice

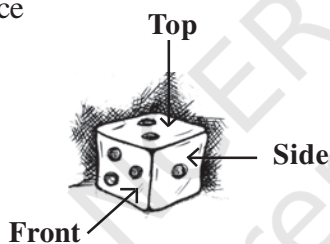

(f) A solid

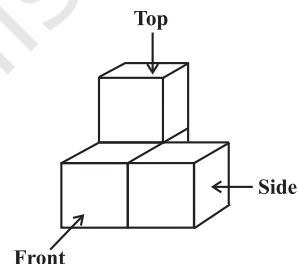

### 10.3 Mapping Space Around Us

You have been dealing with maps since you were in primary classes. In Geography, you have been asked to locate a particular State, a particular river, a mountain etc., on a map. In History, you might have been asked to locate a particular place where some event had occurred long back. You have traced routes of rivers, roads, railwaylines, traders and many others.

How do we read maps? What can we conclude and understand while reading a map? What information does a map have and what it does not have? Is it any different from a picture? In this section, we will try to find answers to some of these questions. Look at the map of a house whose picture is given alongside (Fig 10.1).

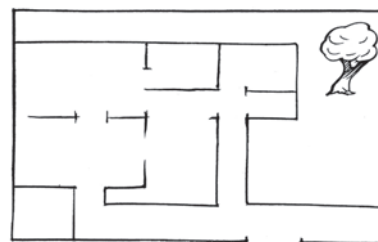

Fig 10.1





You will find that when the maps are drawn of same size, scales and the distances in the two maps will vary. That is 1 cm of space in the map of Delhi will represent smaller distances as compared to the distances in the map of India.

The larger the place and smaller the size of the map drawn, the greater is the distance represented by 1 cm.

Thus, we can summarise that:

1. A map depicts the location of a particular object/place in relation to other objects/places.
2. Symbols are used to depict the different objects/places.
3. There is no reference or perspective in map, i.e., objects that are closer to the observer are shown to be of the same size as those that are farther away. For example, look at the following illustration (Fig 10.4).



Fig 10.4

4. Maps use a scale which is fixed for a particular map. It reduces the real distances proportionately to distances on the paper.

### DO THIS

1. Look at the following map of a city (Fig 10.5).

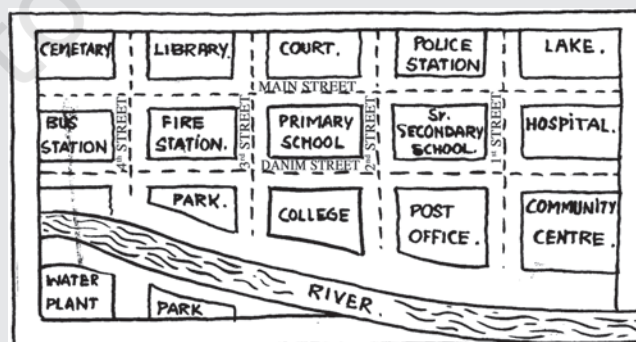

Fig 10.5

- (a) Colour the map as follows: Blue-water, Red-fire station, Orange-Library, Yellow-schools, Green-Parks, Pink-Community Centre, Purple-Hospital, Brown-Cemetery.

- (b) Mark a Green 'X' at the intersection of 2nd street and Danim street. A Black 'Y' where the river meets the third street. A red 'Z' at the intersection of main street and 1st street.
- (c) In magenta colour, draw a short street route from the college to the lake.
2. Draw a map of the route from your house to your school showing important landmarks.

## EXERCISE 10.2

1. Look at the given map of a city.

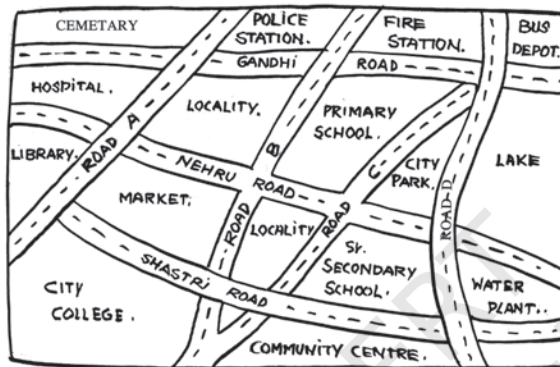

Answer the following.

- (a) Colour the map as follows: Blue-water, red-fire station, orange-library, yellow - schools, Green - park, Pink - College, Purple - Hospital, Brown - Cemetery.
- (b) Mark a green 'X' at the intersection of Road 'C' and Nehru Road, Green 'Y' at the intersection of Gandhi Road and Road A.
- (c) In red, draw a short street route from Library to the bus depot.
- (d) Which is further east, the city park or the market?
- (e) Which is further south, the primary school or the Sr. Secondary School?
2. Draw a map of your class room using proper scale and symbols for different objects.
3. Draw a map of your school compound using proper scale and symbols for various features like play ground main building, garden etc.
4. Draw a map giving instructions to your friend so that she reaches your house without any difficulty.

## 10.4 Faces, Edges and Vertices

Look at the following solids!

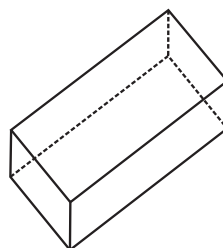
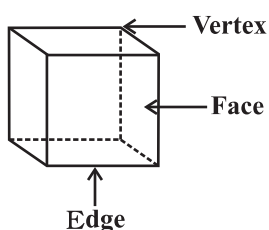

### Riddle

I have no vertices.  
I have no flat faces. Who am I?

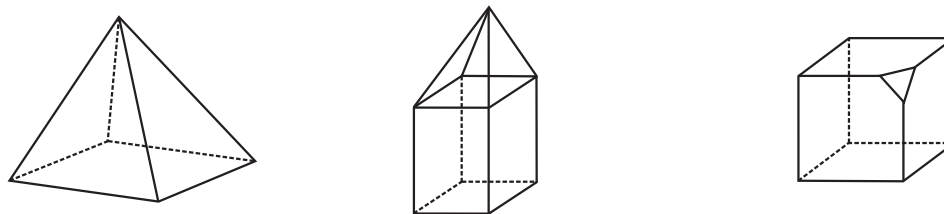

Each of these solids is made up of polygonal regions which are called its **faces**; these faces meet at **edges** which are line segments; and the edges meet at vertices which are **points**. Such solids are called **polyhedrons**.

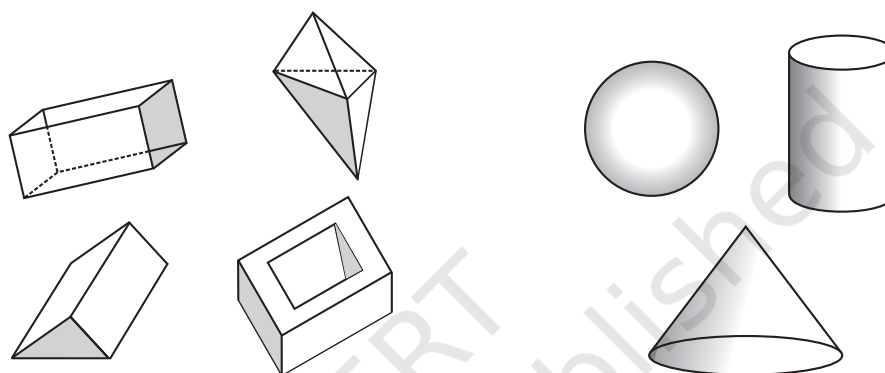

**These are polyhedrons**

**These are not polyhedrons**

How are the polyhedrons different from the non-polyhedrons? Study the figures carefully. You know three other types of common solids.

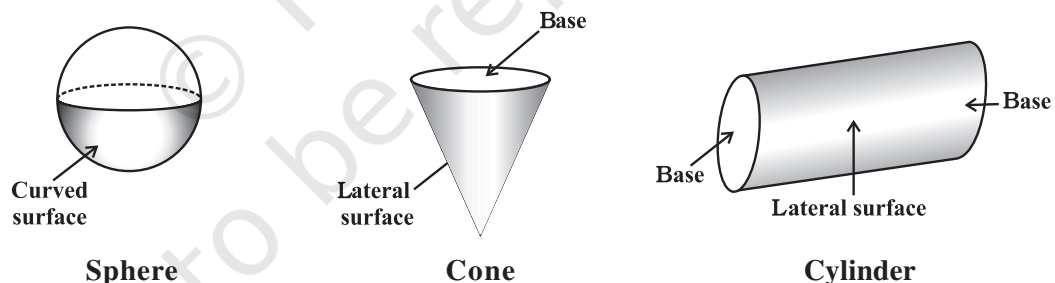

**Sphere**

**Cone**

**Cylinder**

**Convex polyhedrons:** You will recall the concept of convex polygons. The idea of convex polyhedron is similar.



**These are convex polyhedrons**

**These are not convex polyhedrons**

**Regular polyhedrons:** A polyhedron is said to be **regular** if its faces are made up of regular polygons and the same number of faces meet at **each** vertex.

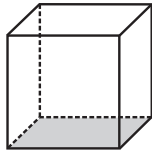

This polyhedron is regular. Its faces are congruent, regular polygons. Vertices are formed by the same number of faces

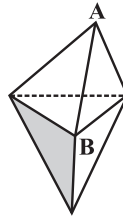

This polyhedron is not regular. All the sides are congruent; but the vertices are not formed by the same number of faces. 3 faces meet at A but 4 faces meet at B.

Two important members of polyhedron family around are prisms and pyramids.

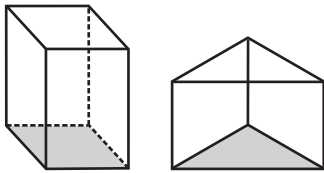

These are prisms

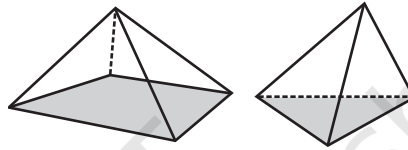

These are pyramids

We say that a **prism** is a polyhedron whose base and top are congruent polygons and whose other faces, i.e., lateral faces are parallelograms in shape.

On the other hand, a **pyramid** is a polyhedron whose base is a polygon (of any number of sides) and whose lateral faces are triangles with a common vertex. (If you join all the corners of a polygon to a point not in its plane, you get a model for pyramid).

A prism or a pyramid is named after its base. Thus a hexagonal prism has a hexagon as its base; and a triangular pyramid has a triangle as its base. What, then, is a rectangular prism? What is a square pyramid? Clearly their bases are rectangle and square respectively.

### DO THIS

Tabulate the number of faces, edges and vertices for the following polyhedrons: (Here 'V' stands for number of vertices, 'F' stands for number of faces and 'E' stands for number of edges).



Solid	F	V	E	F+V	E+2
Cuboid					
Triangular pyramid					
Triangular prism					
Pyramid with square base					
Prism with square base					

What do you infer from the last two columns? In each case, do you find  $F + V = E + 2$ , i.e.,  $F + V - E = 2$ ? This relationship is called **Euler's formula**. In fact this formula is true for any polyhedron.

## THINK, DISCUSS AND WRITE

What happens to  $F$ ,  $V$  and  $E$  if some parts are sliced off from a solid? (To start with, you may take a plasticine cube, cut a corner off and investigate).

## EXERCISE 10.3

- Can a polyhedron have for its faces
  - 3 triangles?
  - 4 triangles?
  - a square and four triangles?
- Is it possible to have a polyhedron with any given number of faces? (**Hint:** Think of a pyramid).
- Which are prisms among the following?

(i)



A nail

(ii)

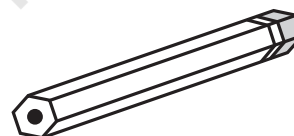

Unsharpened pencil

(iii)

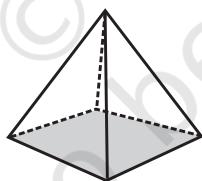

A table weight

(iv)

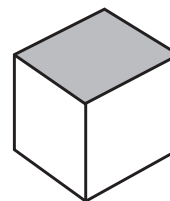

A box

- How are prisms and cylinders alike?
  - How are pyramids and cones alike?
- Is a square prism same as a cube? Explain.
- Verify Euler's formula for these solids.

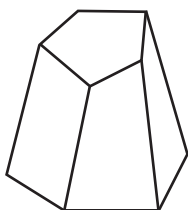

(i)

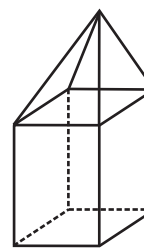

(ii)

7. Using Euler's formula find the unknown.

<b>Faces</b>	?	5	20
<b>Vertices</b>	6	?	12
<b>Edges</b>	12	9	?

8. Can a polyhedron have 10 faces, 20 edges and 15 vertices?

### WHAT HAVE WE DISCUSSED?

1. Recognising 2D and 3D objects.
2. Recognising different shapes in nested objects.
3. 3D objects have different views from different positions.
4. A map is different from a picture.
5. A map depicts the location of a particular object/place in relation to other objects/places.
6. Symbols are used to depict the different objects/places.
7. There is no reference or perspective in a map.
8. Maps involve a scale which is fixed for a particular map.
9. For any polyhedron,

$$F + V - E = 2$$

where 'F' stands for number of faces, V stands for number of vertices and E stands for number of edges. This relationship is called **Euler's formula**.



## NOTES

© NCERT  
not to be republished